

# ALMACRAWLER



## ATHENA 870-BL EVO

Translation of original instructions



Prior to commissioning the machine read carefully this Use and Maintenance Manual

Note: table of contents at the end of the manual

Edition	Date
00	23/07/2020

## 1 GENERAL INFORMATION

### 1.1 Documents supplied with each machine

- CE Declaration of conformity
- Instruction Manual (this manual)
- Spare Parts Manual
- Wiring diagrams and hydraulic layouts
- Report register

### 1.2 Details of Manual

- Instruction manual for *Elevating work platform*
- Version: *ATHENA 870-BL EVO*

**Note:** Some of the photos and illustrations may not refer specifically to the version of the machine in your possession, but provide indications concerning the purpose for which they have been included.

### RECIPIENTS OF THIS MANUAL

- User
- Maintenance technician



**Warning:** the servicing personnel must be properly trained and experienced.



**CAREFULLY READ** this manual before performing any operation on the machine.  
**If in doubt, do not improvise. Call the assistance service.**

### 1.3 Ownership of the information

This document contains confidential information. All rights reserved.

This manual may be neither partially nor totally duplicated without the prior written authorization of ALMAC s.r.l.

This document may only be used by the customer to whom the manual has been supplied along with the machine, and only for the purpose of use and maintenance of the machine to which the manual refers.

ALMAC s.r.l. hereby declares that the information in this manual was congruent with the technical and safety specifications of the machine to which the manual refers. The manufacturer declines all liability for direct or indirect damage to persons, things or animals deriving from use of the machine in conditions differing from those envisaged.

ALMAC s.r.l. reserves the right to make changes or improvements, without prior notice, to the documentary material and to the machines, including marketed machines of the same model as that to which this manual refers but with a different serial number.

The information contained in this manual refers in particular to the machines specified in "*Identification data of the M.E.W.P.*" and related documentation.

### 1.4 Manufacturer's identification data

ALMAC S.r.l.

e-mail: [info@almac-italia.com](mailto:info@almac-italia.com)

Tel. +39 0375 83 35 27

Fax. +39 0375 78 43 50

VAT no. and Tax Code 02559800350

Registered Office

Viale Ruggeri 6/A  
42016 - Guastalla (RE) - Italy

Operational Headquarters

Via Caduti sul Lavoro 1  
42012 - Viadana (MN) - Italy

### 1.5 MEWP identification data

The machine named ATHENA 870-BL EVO is defined according to the technical standards in force (ref. UNI EN 280:2015), as:

**Mobile Elevating Work Platform (MEWP), belonging to group B, type 3 (point 1.4-EN 280)**

Meanings:

**GROUP B:** All types of mobile elevating work platforms other than "Group-A" (mobile elevating work platforms where the vertical projection of the centre of the platform area in all platform configurations at the maximum frame inclination specified by the manufacturer is always inside the tipping lines).

**TYPE 3:** mobile elevating work platforms where travelling with a raised work platform is controlled from a point of control on the work platform.

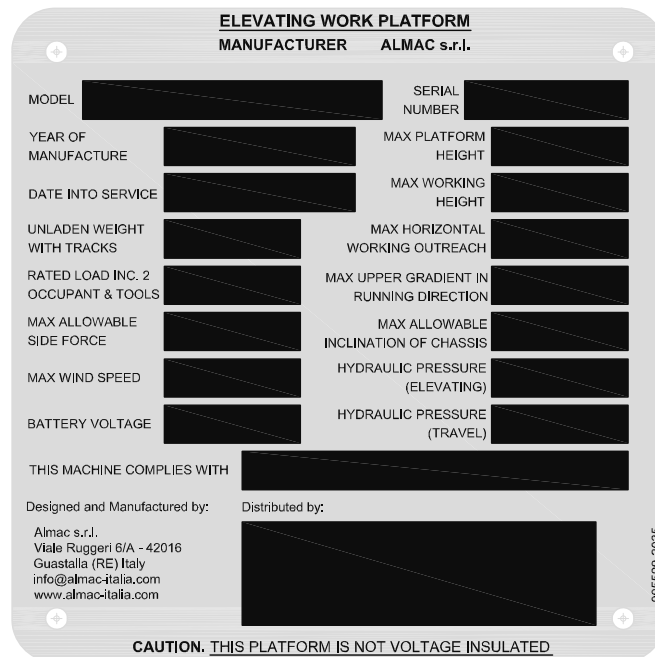

Identification plate

Refer to the data on the identification plate for an exact identification of the MEWP.



### 1.6 Performance

Below are the configurations that the mobile elevating work platform can have during operation and transport.

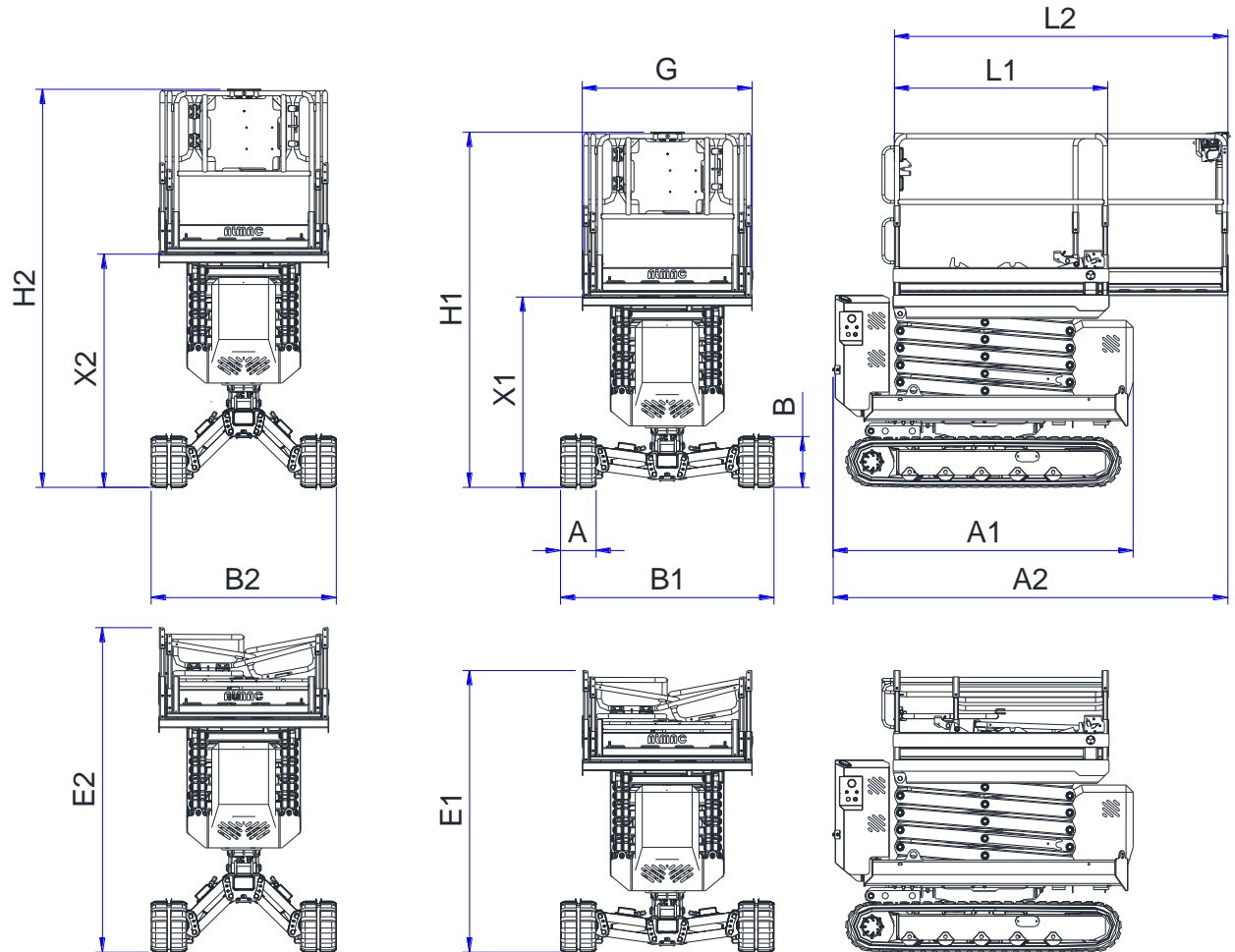

*The work platform is provided of foldable guardrails not removable.*

*Remove and install the guardrails is permitted only for special transport situations and only by specialist maintenance personnel authorized by the manufacturer.*

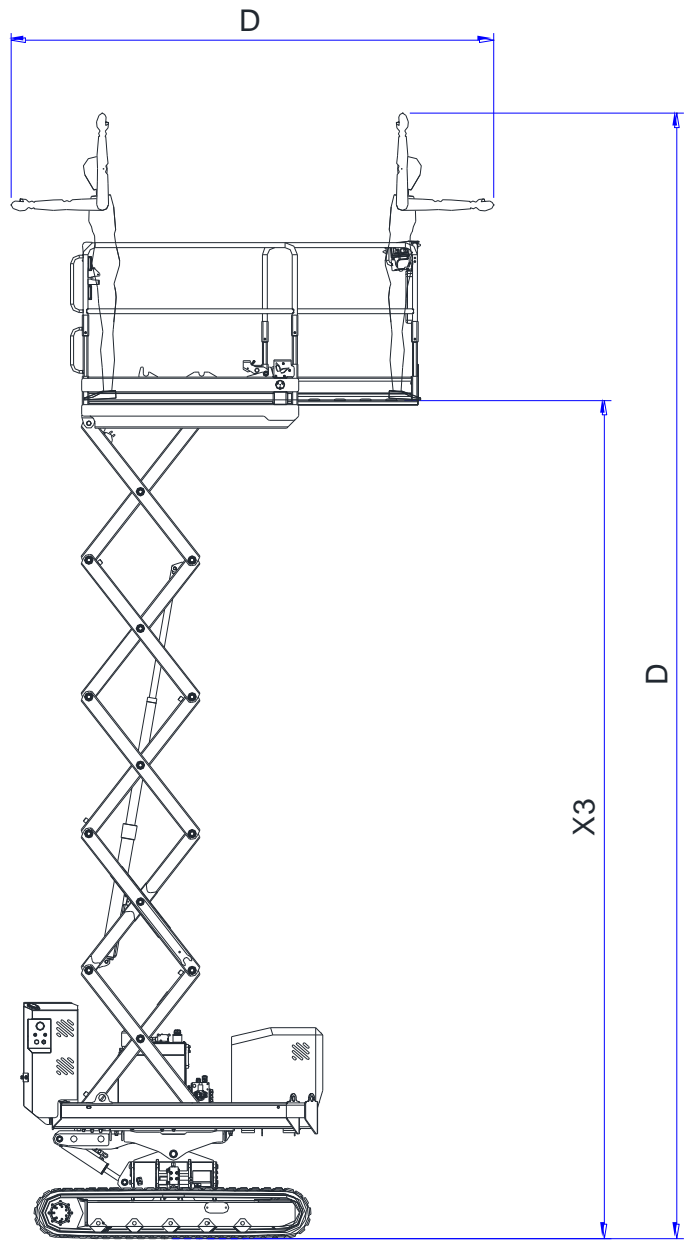
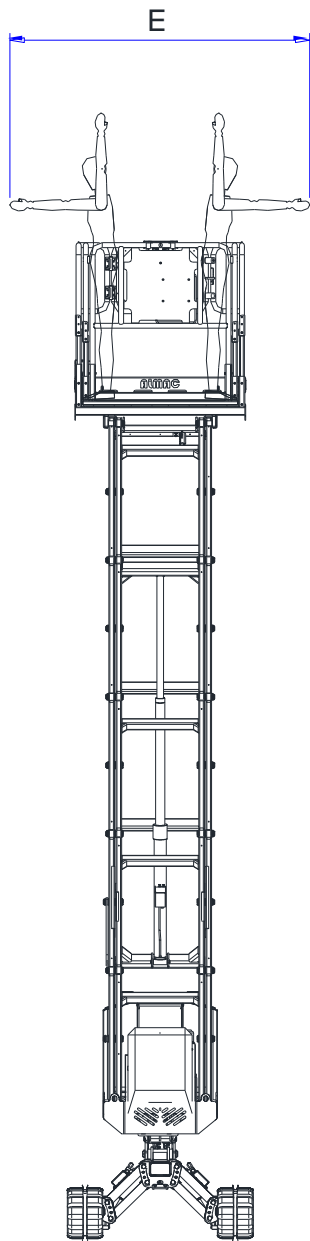

Dimensions		
<b>Length</b> With basket closed	<b>A1</b>	2.11 m
<b>Length</b> With basket extended	<b>A2</b>	2.78 m
<b>Maximum width</b> Track width	<b>B1</b>	1.50 m
<b>Maximum width</b> Track narrow	<b>B2</b>	1.30 m
<b>Minimum high</b> Track width	<b>H1</b>	2.50 m
<b>Minimum high</b> Track narrow	<b>H2</b>	2.80 m
<b>Basket large</b>	<b>G</b>	1.2 m
<b>Basket large</b> With basket closed	<b>L1</b>	1.50 m
<b>Basket large</b> With basket extended	<b>L2</b>	2.35 m
<b>Tracks sizes</b>	<b>AxB</b>	250 mm x 360 mm
<b>Minimum high floor level</b> Track width	<b>X1</b>	1.34 m
<b>Minimum high floor level</b> Track narrow	<b>X2</b>	1.64 m
<b>Minimum high (only for transport)</b> Track width / guardrails closed	<b>E1</b>	1.98 m
<b>Minimum high (only for transport)</b> Track narrow / guardrails closed	<b>E2</b>	2.28 m
<b>Track min-max</b>	<b>L</b>	1.30 m – 1.50 m
<b>Floor level maximum high</b>	<b>X3</b>	5.87 m
<b>Maximum working level</b>	<b>C</b>	7.87 m
<b>Max. working area (length)</b>	<b>D</b>	3.38 m
<b>Max. working area (large)</b>	<b>E</b>	2.10 m

Specification		
Capacity	kg	250
Nr operators onto the basket		2
Lifting time	s	15
Falling time	s	20
Hydraulic pressure	bar	200
Hydraulic oil tank capacity	l	20
Overcame sloop	°	25
Max lateral sloop	°	15
Max longitudinal sloop	°	20 / 16
Speed	km/h	2.0
Weight	kg	2460
Max wind speed admitted	m/s	12.5
Voltage and battery capacity	V/ Ah	12 /50
Battery Weight	kg	15
Noise power Lw	dBA	103
Noise level operator site Lp (inside industrial area)	dBA	84.5 ± 2.6
Noise level operator site Lp (outside on asphalt)	dBA	79.5 ± 2.6
Max peak level L <sub>p</sub> peak	dBC	106.0
Hand/arm system vibrations (support operators hands)	m/s <sup>2</sup>	< 2.5
Full body vibrations (platforms on flat ground)	m/s <sup>2</sup>	0.52 ± 0.10 *
Hand/arm system vibrations (support operators hands)	m/s <sup>2</sup>	0.59 ± 0.12 **

\* refers on lifted platform (workload) \*\* refers to the limit of transportation share platform

Standard specification
Proportional electro-hydraulic commands
Diesel engine (Kubota Z482-E3B)
Electric Motor 220 V/ 50 Hz
Electric start on-off in basket
Electronic accelerator
Inclination electronic control
Overload alarm
Electronic protection anti-shearing
Hours-meter
Harness fixing points
Lifting-transport fixing points
Acoustic alarm
Hand pump
Foot Pedal



Engine data	Z482-E3B
Weight	53.1 kg
Engine type	VERTICAL, 4-CYCLE LIQUID COOLED
Displacement	479 cm <sup>3</sup>
Power	9.9 kW @ 3600 rpm
Torque	30 Nm @ 2500 rpm
Oil (quantity)	2.5 Lt
Diesel tank capacity	30 Lt
Cooling	NATURALLY ASPIRATED

Engine data	Electric
Weight	14 kg
Power	2.2 kW
Torque	10.2 Nm
Rpm	1400
Supply	220 V / 50 Hz
Size IEC	90

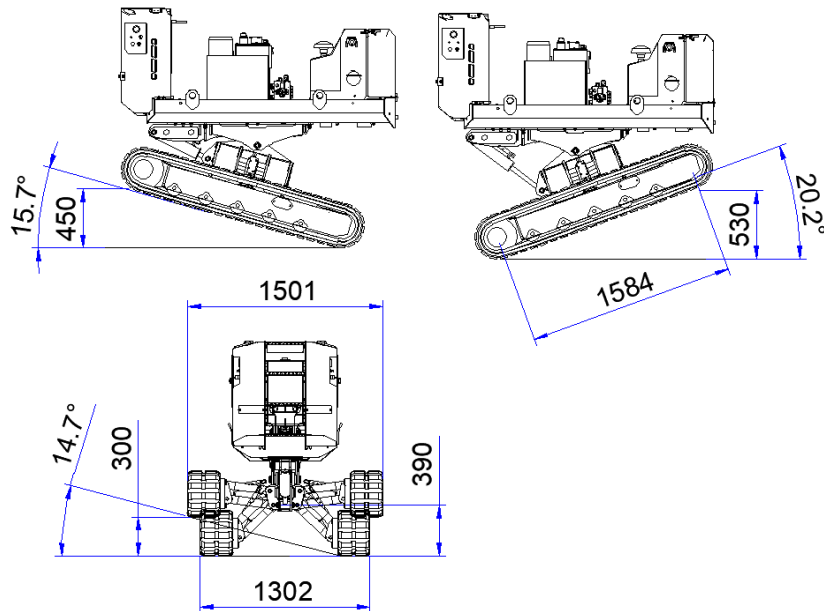

*Maximum inclinations allowed*

*Maximum admitted transport high  
(Manual levelling and the adjustment of the travel speed admitted)*

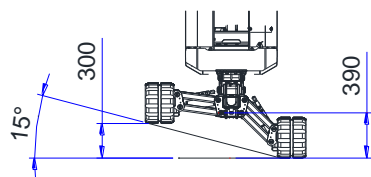
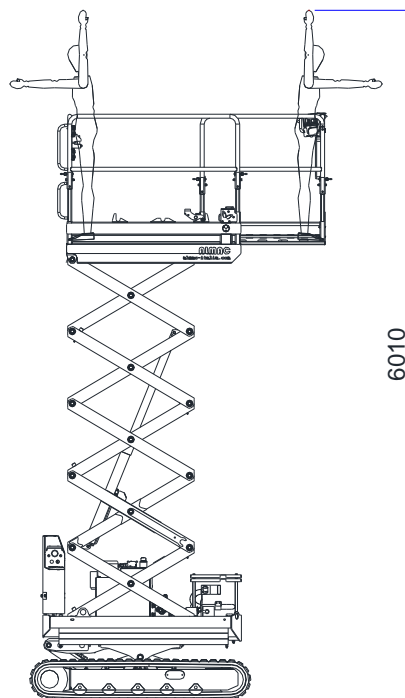
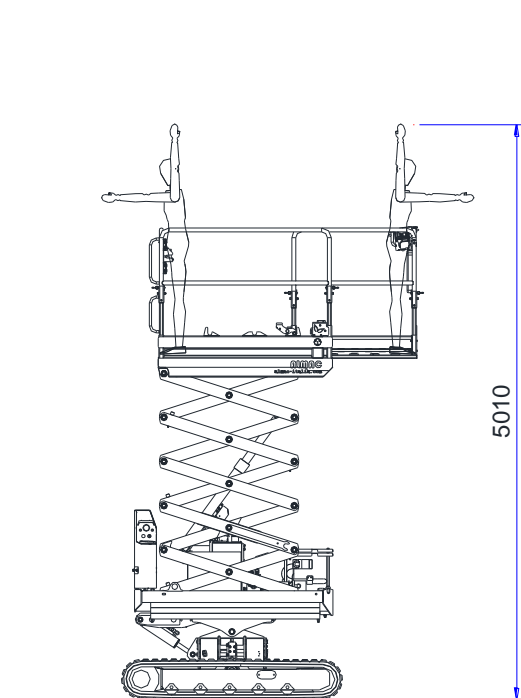

MAXIMUM WORKING HEIGHT WITH TRAVELLING PERMITTED AND UNLIMITED CARRIAGE WIDTH

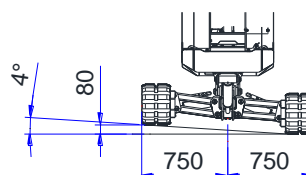

MAXIMUM WORKING HEIGHT WITH TRAVELLING PERMITTED BUT LIMITED CARRIAGE WIDTH

### **1.7 CE Declaration of Conformity**

See facsimile of CE declaration of conformity enclosed with this manual.

The machine described in this manual complies with the following standards:

- Directive 2006/42/EC – Machinery Directive that amends Directive 95/16/EC
- Legislative Decree D.Lgs 17/2010 – Implementation of Machinery Directive 2006/42/EC
- UNI EN 280:2015 - Mobile elevating work platforms - Design calculations - Stability criteria - Construction - Safety - Examinations and tests
- \*UNI EN 349:2008 – Minimum gaps to avoid crushing parts of the human body
- EN ISO 12100:2010 Safety of machinery -General principles for design - Risk assessment and reduction

All parts available on the market and “partly completed machinery” installed on the platform conform to the aforementioned Directives and those that specifically govern the product.

*\*For the scissor lifting devices, the anti-shearing function has been used, as provided for in section 5.4.3 of UNI EN 280:2015 with permanent warning signs.*

### **1.8 Warranty**

ALMAC S.r.l. guarantees the equipment it manufactures and undertakes to replace, free of charge and within the shortest possible time, those parts that, in its opinion, possess manufacturing and/or material defects.

Work under guarantee must only be performed by workshops authorized by ALMAC S.r.l. and only when the Customer is up to date with the payments.

The Customer will not be entitled to work under guarantee unless he consigns the equipment for repair within 30 days from the date of the first complaint, to be made in writing.

With the exception of fraud or gross negligence, ALMAC S.r.l. is relieved of all liability towards the Customer for damage deriving from flaws/defects in the traded equipment.

The warranty with which the Customer is provided becomes void if modifications are made to the machines without prior written authorization from ALMAC S.r.l. or should the Customer make incorrect/improper use of the machines.

### 1.8.1 Request for interventions during warranty period and formalities

ALMAC S.r.l. must be notified of requests for spare parts or technical interventions under guarantee as soon as a defect is discovered.

Always indicate the type of machine and its serial number when requesting spare parts under guarantee or technical interventions under guarantee. This information is given on the identification plate of the equipment.

## 1.9 Assistance

As far as the optimum use of the machine and extraordinary maintenance are concerned, this manual does not replace the expertise of the Technical Assistance sent by ALMAC S.r.l. (refer also to the *Maintenance Chapter*).

### 1.9.1 Request for assistance and repairs

To request ALMAC S.r.l. specialized Assistance Service, the Customer may contact:

	<b>SEDE LEGALE</b>	<b>SEDE OPERATIVA</b>
	ALMAC S.r.l. Viale Ruggeri 6/A 42016 Guastalla (RE) Italia	ALMAC S.r.l. Via Caduti sul lavoro 1 46019 Viadana (MN) Tel. +39 0375 833527 Fax. +39 0375 784350 Mail. <a href="mailto:info@almac-italia.com">info@almac-italia.com</a>

In case of intervention request, specify the machine version and serial number; the data is indicated on the identification plate attached to the machine.

### 1.10 Use of the manual



Note: Keep this manual in an accessible place known to all users (operators and maintenance workers).

Note: This manual must be kept in a protected place inside the compartment provided on the work platform so that it can be easily accessed for consultation throughout the entire technical life of the machine.

Note: If this manual is lost or damaged, a new copy must be ordered from the manufacturer. Specify the serial number of the machine (given on the relative identification plate) when requesting a new copy of the manual. The manufacturer undertakes to provide a new copy.

Note: When selling used equipment, this manual and the related attachments must be included and the manufacturer must be informed of the new owner (see *Appendix 3 - Transfer of Ownership*)



Read carefully *Chapter 1 General Information, Chapter 2 Safety information, Chapter 3 Description of the Machine and Performance, Chapter 4 Operating instructions, Chapter 5 Emergency Procedures.*

Always consult the relative chapter when using, servicing the machine or when it is demolished.

## 1.11 Intended use and improper uses

### 1.11.1 Intended use

The machine described in this manual is a self-propelled elevating work platform designed to lift personnel and equipment to perform the following jobs:

- professional gardening and general work
- installation of systems and equipment
- cleaning
- painting and paint removal

The maximum allowed capacity for this model is 250 kg. Consider the following:

- 2 (two) persons each weighing 80 kg
- 90 kg of equipment

An electronic control system prevents the work platform from lifting to any position when the load exceeds approx. 20% of the rated load given in the technical specifications.

The platform was designed and built to be driven only from the console located on the work platform.

The push-button is of the removable type and can only be used by the operator to control the platform exclusively in transport position.

The controls on the ground on the rear side are for EMERGENCY use or MAINTENANCE by qualified personnel.



**Warning:** NEVER exceed the machine's established maximum capacity.

**Warning:** It is FORBIDDEN to transport large slabs or materials since this could increase wind resistance to a considerable extent and cause the machine to tip over.

**Warning:** It is FORBIDDEN to apply horizontal loads to the platform when the machine is moving (e.g. the operators on board must not pull ropes or cables...)

**Warning:** It is FORBIDDEN to use the machine to tow other equipment or vehicles.

**Warning:** the machine is designed to be driven around within public or private areas. It is not designed for road circulation



**Warning:** The machine IS NOT SET FOR OPERATION IN ATEX CLASSIFIED ATMOSPHERES



ALL LOADS must be positioned inside the work platform. NEVER LIFT LOADS HANGING FROM THE PLATFORM, from the lifting structure or from the railings.

If the machine is used in places open to the public or in construction sites where persons may transit or remain in the vicinity, the WORK AREA MUST BE CORDONED OFF in a suitable way (e.g. chains and posts).

### 1.11.2 Improper uses

Any other use not specifically indicated in 1.11.1 *Intended use*.

- The improper uses established for this MEWP include lifting and lowering persons to/from different storeys within space (typical use of elevators).
- It is also forbidden to drive the platform to the ground using the mobile push-button panel with an operator on the work platform.



The platform was designed and built to be driven only from the console located on the work platform. The controls on the ground on the rear side are for EMERGENCY use or MAINTENANCE by qualified personnel.

The push-button panel is of the removable type and can only be used by the operator to control the platform exclusively in transport position.

### **1.11.3 Cases that relieve the manufacturer from liability**

The manufacturer declines all liability in the following cases:

- Use not indicated in this manual
- Improper use of the machine or its use by untrained personnel
- Use that fails to comply with the specific standards
- Lack of scheduled maintenance
- Unauthorized changes or interventions
- Removal of seals
- Use of non-original replacement parts
- Total or partial failure to comply with the instructions
- Failure to perform the Routine Inspections required by the laws in force



## 2 SAFETY INFORMATION

### *2.1 Notification of commissioning and routine inspections*

The work equipment indicated in Annex VII to Legislative decree D.Lgs 81/2008 and successive amendments must be subjected to REGISTRATION and ROUTINE INSPECTIONS by the competent authorities, i.e. INAIL, the National Institute for Insurance Against Industrial Accidents (former ISPESL, Higher Institute for Prevention in the Workplace), the Local Health Authority and other public and private bodies established by the criteria laid down in Ministerial decree DM 11/04/2011.

- The User or Employer must notify Commissioning to the territorially competent National Institute for Insurance Against Industrial Accidents (INAIL) for the purpose of registering the platform.
- Once the platform has been registered, ROUTINE INSPECTIONS must begin. The FIRST of these is performed by INAIL within 45 days (since 21 August 2013) from the date on which the platform is put into service.
- The successive inspections, to be carried out at the frequency indicated in Annex VII to Legislative Decree D.Lgs 81/2008, are carried out by the Local Health Departments (ASL) or, when permitted by the regional laws, by ARPA (Regional Agency for the Protection of the Environment) or by Public or Private undertakings, as freely decided by the Employer or User and in accordance with the established formalities.

Attached are a few EXAMPLES of "notice of commissioning" and "routine inspections". Users should check them each time in the [www.inail.it](http://www.inail.it) portal, according to the installation site in question.

## 2.2 *Fitness of the personnel*

The operators who use the machine must be properly trained, informed, instructed on how to use the machine in safe conditions and must possess a training certificate issued in accordance with the laws in force at the time of use\*.

The operators who use the machine must be over 18 years of age and be recognized as psychophysically fit for the task in question. The following requirements must be ascertained before the operators are allowed to drive the machine:

- sight and hearing in good conditions
- absence of changes induced by use of alcohol or drugs
- psychological equilibrium, absence of depression or stress

Operators who use the machine for professional purposes must undergo health surveillance as required by Legislative decree D.Lgs 81/2008 and successive amendments, particularly with regard to alcohol addiction and alcohol concentration tests.

*\*The law that currently governs health control and surveillance of workers is the Provision of the State-Regions Permanent Conference of 16 March 2006.*



**Note:** ALMAC S.r.l. declines all liability for damage to persons, animals and things deriving from:

- failure to comply with the safety regulations
- use of the machine by unqualified operators
- failure to comply with the recommendations in the documentation supplied

## 2.3 Warnings

The following sign plates are affixed to the machine:

- Identification
- Instructions
- Command/prohibition sign plates
- Caution
- Danger

### 2.3.1 Plates indicating instructions, obligations, dangers, prohibitions and warnings

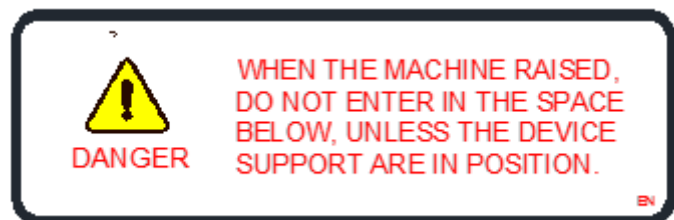
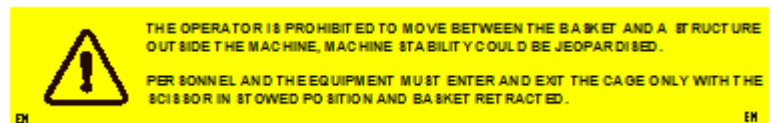

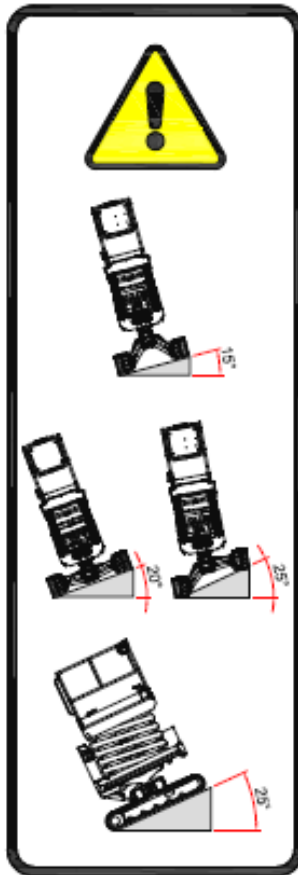
**Maximum inclination of the ground:**

- Front inclination of the ground: The maximum front inclination of the ground to stay safe is 25°. There is no electronic control for this condition, which is at the discretion of the operator.
- Lateral inclination of the ground: The maximum lateral inclination of the ground, keeping the frame as level as possible, to stay safe is 25°. There is no electronic control for this condition, which is at the discretion of the operator.
- Lateral inclination of the ground with a narrow track: The maximum lateral inclination of the ground, with a narrow track, to stay safe is 15°. There is no electronic control for this condition, which is at the discretion of the operator.

Sticker with maximum inclinations of the ground dangerous for the risk of tipping over and slipping, travelling with the machine completely lowered

Note: The inclinations listed on the plate above refer to those LIMITS that cannot be exceeded with the machine. Almac s.r.l. has provided an electronic control system on the platform which limits the movements of the machine when the maximum allowed inclinations have been exceeded, but not in the transport configuration

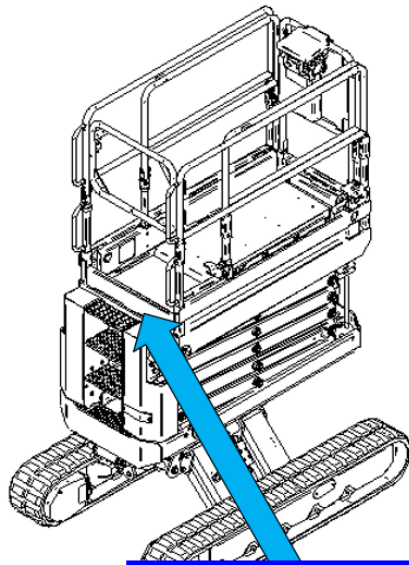

**MAX 250Kg =  +  90Kg**

 THE OPERATOR IS PROHIBITED TO MOVE BETWEEN THE BASKET AND A STRUCTURE OUTSIDE THE MACHINE, MACHINE STABILITY COULD BE JEOPARDISED.  
PER SONNEL AND THE EQUIPMENT MUST ENTER AND EXIT THE CAGE ONLY WITH THE SCISSOR IN EXTENDED POSITION AND BASKET RETRACTED.

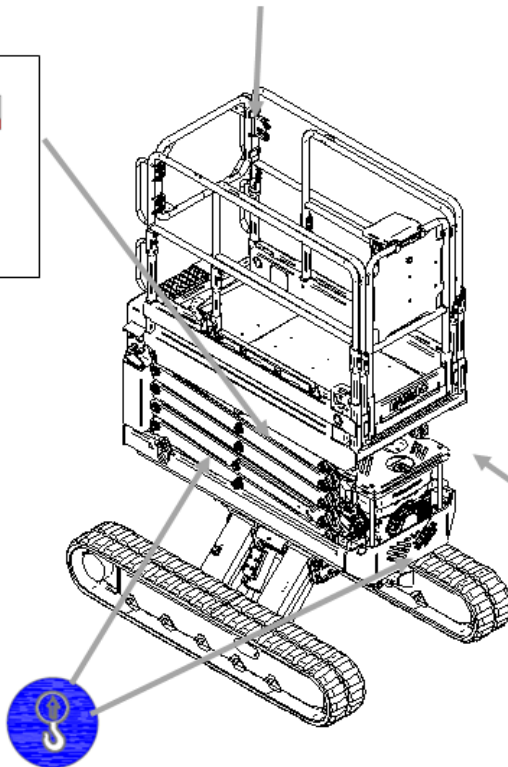

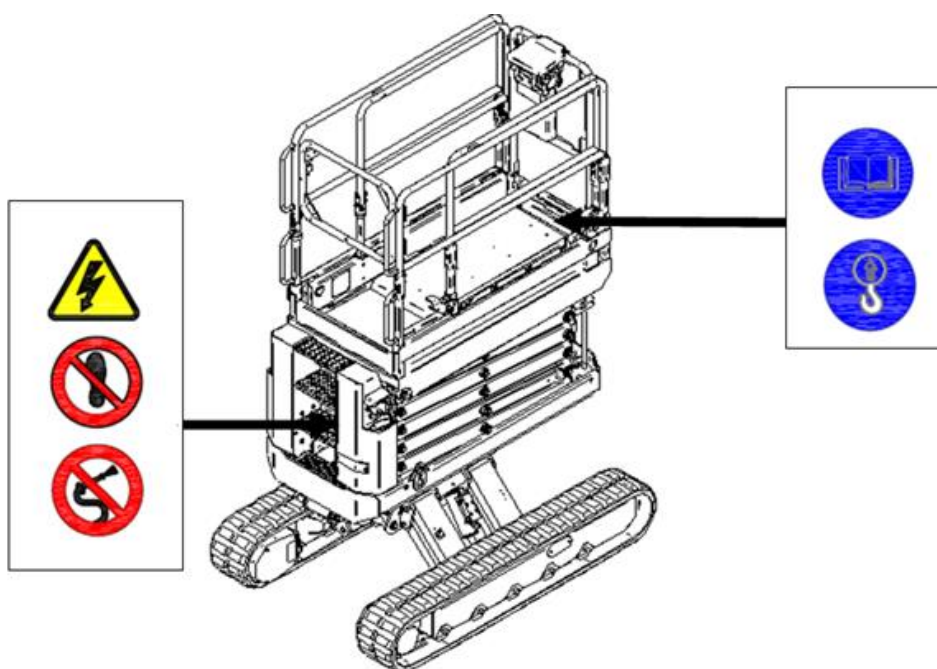







Note: The plates are affixed to the machine for the purpose of helping the operator and/or warning him of the risks to which he may be exposed when he uses the machine. In no way does the information on the plates substitute this Manual, which is the only reference document containing complete information.



Comply with the indications on the sign plates. Failure to comply with these indications may result in serious injuries and even death, and in any case could endanger the operators and/or exposed persons. Make sure that the sign plates are always affixed and legible. If this is not the case, they must be fastened back in place or replaced.

## 2.3.2 Meanings of the sign pictograms

	<b>Warning / Danger.</b> This symbol means that you must take care or that danger is present. Failure to comply with this alert indication could cause damage to the machine, the operator or exposed persons.
	<b>Warning.</b> This symbol means that you must take care of hot parts that could cause burns. Do not touch.
	<b>Warning.</b> This symbol means that you must take care of an electric panel or other live electrical devices.
	<b>Danger.</b> This symbol means that there is a danger of injury to the upper and lower limbs due to moving parts. Do not insert your hands or feet into openings that could move and cut or between moving parts.
	<b>Forbidden.</b> Means that it is forbidden to use water at high pressure on these surfaces
	<b>Forbidden.</b> Means that it is forbidden to climb onto the parts indicated by this symbol.
	<b>Sign plate.</b> Take care of the moving scissor components.
	<b>Required.</b> The machine is designed with safety belt hooks. The use of seat belts is recommended, but the choice is in any case postponed to the site safety manager.
	<b>Required.</b> This symbol means that you must use the indicated anchor points for lifting the machine.
	<b>Required.</b> This symbol means that you must comply with the instructions in the “use and maintenance manual”.

## 2.4 Provisions and prohibitions

- Read this manual carefully before starting, using, servicing or performing other operations on the machine.
- The MEWP must always be kept in perfect conditions by following the maintenance program described in the *Maintenance Chapter*.
- Do not wear rings, wrist watches, jewellery, unfastened or loose clothing such as neck ties, torn garments, scarves, unbuttoned jackets or garments with open zip fasteners that could get caught up in moving parts.
- Wear approved safety garments, such as non-slip footwear and a reflective vest.
- To lower the slipping or tripping risk to the minimum, always keep the operator compartment, platform surfaces, steps, handrails and grip bars clean and free from all foreign objects or traces of oil, mud and snow
- Clean the soles of your footwear before getting on the M.E.W.P.
- **THE OPERATOR MUST NOT MOVE BETWEEN THE WORK PLATFORM AND A STRUCTURE OUTSIDE THE MACHINE; THE MACHINE MAY BECOME UNSTABLE.**
- **THE PERSONNEL AND THE EQUIPMENT MUST ENTER AND EXIT THE WORK PLATFORM ONLY WITH THE PLATFORM IN THE TRANSPORT POSITION.**
- Do not use the controls or flexible hoses as hand grips
- Do not lean over the railings around the work platform
- Warn the persons in charge of maintenance if the machine operates in a faulty way
- Make sure that all guards and other protections are positioned correctly and that all the safety devices are installed and efficient.
- Do not use the platform in places where there is a risk of explosion or fire outbreaks.
- Do not use jets of water or high-pressure washers to clean the platform.
- ***It is mandatory for the operator on the platform to use a protective HARD HAT, in accordance with the current safety laws. The operator on the ground must also wear a hard-hat.***
- **USE OF THE PLATFORM ALWAYS REQUIRES 2 OPERATORS, ONE OF WHOM ON THE GROUND and able to perform the emergency operations described in this Manual.**
- The platform must not be used if there is insufficient light, since it is not fitted with its own lights.
- The control box in the work platform must always be protected with the casing supplied if it rains or when the machine is parked.



## 2.5 Transport and loading

You are advised to check the dimensional limits established for means of transport if the machine must be transported to its specific work site.

The machine can be loaded onto the vehicle in two different ways:

- 1) **Using chutes and the platform driving controls:** after having fully LOWERED the platform, the operator can operate the machine by following the instructions given in the dedicated chapter, driving directly onto the transport means. In this case, make sure that the ramp gradient is within the gradeability indicated in the PERFORMANCE data and that the bearing capacity of the chutes suits the weight of the machine.

**Note:** the machine has an advanced traction control "Direction-Control" (DC-S on the control panel) which allows it to be moved in a straight line using a single joystick. It is advisable to use this operating mode with the platform in the maximum track width and in turtle mode, after the aligning it with the ramps.

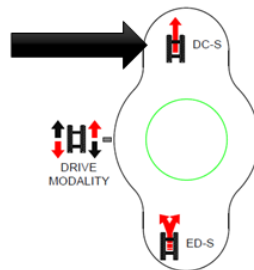

The mobile push-button panel can be removed, and the machine can be driven with the operator on the ground: with the platform in the transport position, the operator can move the machine directly from the ground using the portable push-button panel.



- 2) Lifting the platform using a CE certified beam (not included) and using hooks and steel ropes hooked to the holes marked with signs (see photo below).

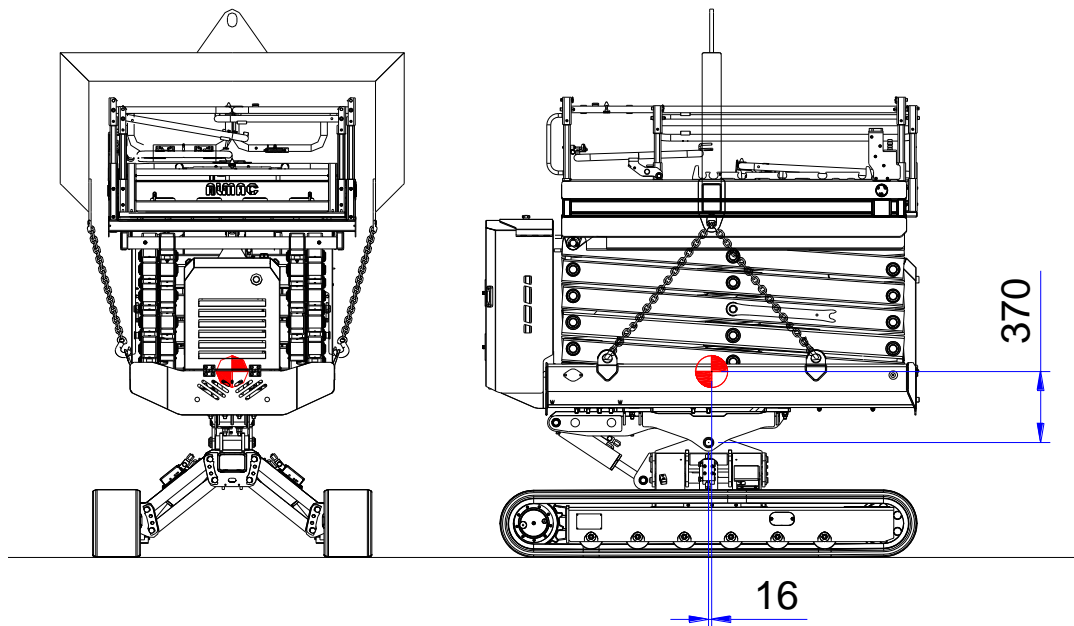

Warning: the maximum weight of ATHENA BL in the heaviest configuration is 2450Kg

Warning: The connecting rods of the chassis should be arranged as shown in the figure, that is with the frame fully lifted (chassis narrow)

Warning: The railings must be folded



Note: Once the machine has been loaded onto the vehicle, it must be fastened in place using belts; connect them to the special red eye-bolts.

Note: Make sure that the platform is FULLY LOWERED before transporting the machine.

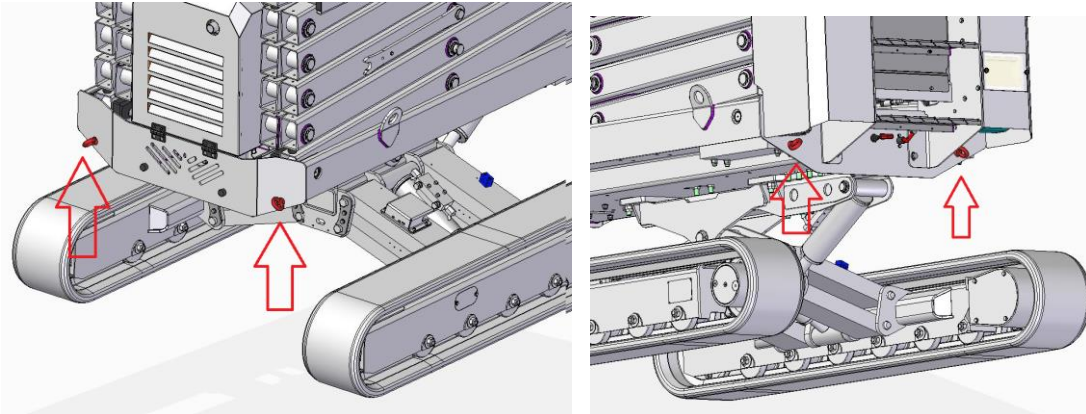

Warning: the chassis must be completely lowered (chassis wide)

Warning: Do not tighten the fixing belts too much, so as not to damage the eye-bolts.

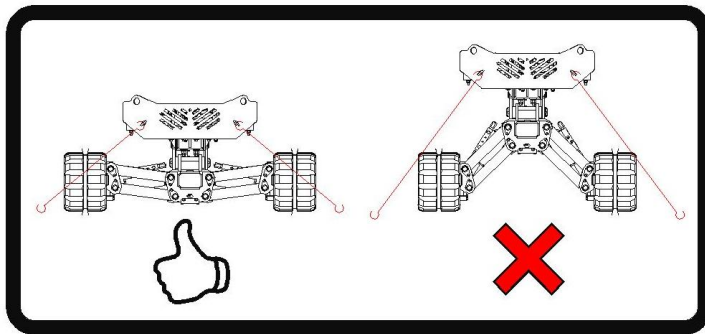

## ***2.6 Checks on the machine before each use***

- Visually check under and around the machine to make sure that there are no oil or fuel leaks. If leaks are discovered, follow the MAINTENANCE instructions.
- Make sure that there is no hydraulic oil leaking from the hoses and from the other components (cylinders, distributors, fittings, etc.).
- Check that there are no cut or worn electrical cables and that the connectors are correctly secured.
- Check the fuel level before starting so as to prevent interruptions while working.
- Check the engine oil level.
- Check the hydraulic oil level.
- Do not run the engine in closed areas like garages or similar. The engine exhaust gas contains carbon monoxide, a poisonous gas that can quickly saturate a closed space and cause difficulties or even death.
- Make sure that none of the screws, bolts or ferrules are loose or missing.
- Make sure that all the "Seeger" safety rings are present and correctly in place with their washers.
- Make sure that all the pins are in place and correctly secured.
- Check that the steel structure is not deformed.
- Make sure there are no cracks in the welds, damage or abnormal wear
- Make sure the tracks are not cut or abnormally worn
- Always check to make sure that the track tension is correct
- Check, and if necessary grease, the scissor runners, both those in contact with the platform and those in contact with the lower frame.
- Check that the manual, the plates and the stickers are on the machine.
- Make sure that the 12V internal combustion engine ignition battery is fully charged; a simple way to check is turning on the internal combustion engine, which must turn on easily.
- Make sure that the gate leading to the platform closes and locks itself automatically once released.

## 2.7 General safety indications on the use of the platform

The instructions given below must be followed.

- It is forbidden to use ladders or other structures in the basket to increase the height of the machine.
- It is forbidden to place structures inside the basket to increase the surface area exposed to the wind.
- It is forbidden to work near high voltage overhead electric power lines. Moreover, the work platform must always be kept at a safety distance of at least 5 metres from cables. For voltages greater than 132KV, refer to the table below.

Table 17		Table of safety distances from live power lines	
Nominal Voltage (kV)		Minimum distance (m)	
$\leq 1$		3	
$1 < U_n \leq 30$		3,5	
$30 < U_n \leq 132$		5	
$> 132$		7	

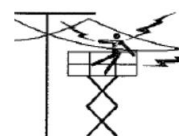

- Do not use the machine during storms. You could be struck by lightning.
- It is forbidden to use the machine if the wind speed exceeds 12.5 m/s.
- Use the MEWP only within the allowed temperature range
- It is forbidden to get on or off the MEWP when the platform is raised
- It is forbidden to load or unload objects from the MEWP when the platform is raised.
- It is forbidden to exceed the capacity of the MEWP; the capacity is the work load for which the platform has been designed and includes the weight of the operators and the tools used for their specific tasks (see relative data plate)
- It is forbidden to use the platform on soft, slippery or unstable ground.

Type of terrain, geomorphological characteristics	Permitted surface pressure	
loose, non-compact soil	in general, not solid; requirement for particular measures	
incohesive soil, quite compact, sand, gravel	2.0 kg/cm <sup>2</sup>	0.2 N/mm <sup>2</sup>
semi-solid cohesive soil	1.0 kg/cm <sup>2</sup>	0.1 N/mm <sup>2</sup>
solid cohesive soil	2.0 kg/cm <sup>2</sup>	0.2 N/mm <sup>2</sup>
hard cohesive soil	4.0 kg/cm <sup>2</sup>	0.4 N/mm <sup>2</sup>
Rock, concrete, road paving suited to the transit of heavy vehicles	over 10.0 kg/cm <sup>2</sup>	over 1 N/mm <sup>2</sup>

### 2.8 Safety indications on the use of the travel function

The instructions given below must be followed.

- Make sure movements are done on flat, sturdy ground. To do this, use the spirit level located on the work platform.
- Make sure that there are no hollows or ridges in the floor and that there is enough room for the machine to pass through.
- Make sure that there are no bystanders or obstructions in the surrounding area before moving off
- Do not CHANGE DIRECTION on kerbs, rocks or appreciable differences in level (> 10 cm) when driving the machine. In this case, always proceed perpendicularly to the obstacles.

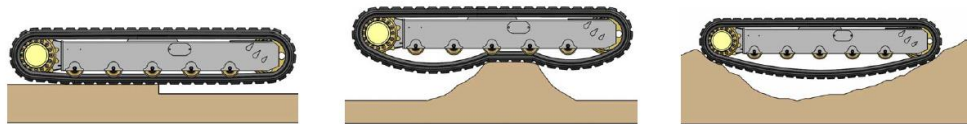

- If you must drive up a slope, do not change direction when the ground changes from flat to sloping. If this is absolutely necessary, perform the manoeuvre gradually.

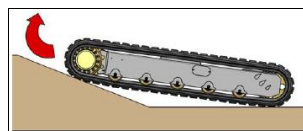

- Do not drive along the edge of slopes or over uneven ground with one track horizontal and the other slanting or partially raised (>10°) as this will damage

the tracks. ALWAYS PROCEED WITH THE TRACK SHOES RESTING ON THE SAME HORIZONTAL PLANE.

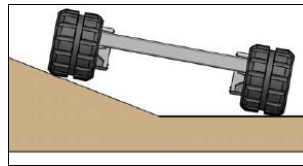

- Driving over an obstacle creates a gap between the bearing rollers and track, which could consequently slip out of its housing.

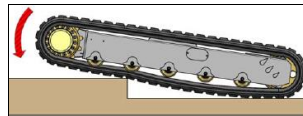

- If you change direction in a situation where the track could move sideways owing to an obstruction, the track could slip out of its housing.

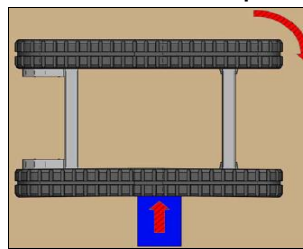

- Check to make sure that there are no bystanders near moving parts when the platform is lowered.



**Warning:** for inclined floors, pay warning to the correct LEVELLING direction. Avoid inclining the platform beyond what is necessary towards the lower side of the platform! **Warning:** manual levelling is allowed only when the transit area of the platform is lower than 2mt from the ground.



- Avoid smooth, slippery and/or icy surfaces and those covered with sand: they could cause a risk of sliding or tipping during levelling.

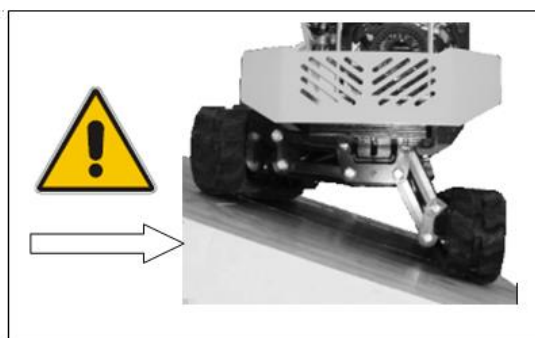

NO ICE!

NO SAND!

NO DUST OR SMOOTH SURFACES!



**Warning:** during movement with ELECTRICAL POWER, be careful of the connection cable in order to avoid dangerously crushing the cable itself!





### ***2.9 Mandatory safety indications to follow before lifting the work platform above the transport height***

The instructions given below must be followed.

After having levelled it, lift the work platform only after making sure, both visually and by moving inside the work platform, that all 4 ends of the tracks rest on the ground.

Avoid the following situation for both tracks:



The ring gear of the wheel drive units and the track tensioner wheels must all be resting on the ground.

If even one of them is not in contact with the ground, the stabiliser area will be reduced and, consequently, the platform will be unstable and there will be the risk of overturning.

### ***2.10 Safety checks on the operation of the platform, to be performed before use***

The instructions given below must be followed.

- With the platform in the transport configuration, place the machine with the frame tilted with respect to the horizontal by a value greater than  $0.5^\circ$  on the lateral. Operate the platform lifting control, make sure that the system automatically brings the frame to the horizontal position
- With the platform in the transport configuration, place the machine with the frame tilted with respect to the horizontal by a value greater than  $0.5^\circ$  on the longitudinal. Operate the platform lifting control, make sure that the system automatically brings the frame to the horizontal position
- With the platform in the transport configuration, place the machine with the frame tilted with respect to the horizontal at the maximum angle both on the longitudinal and on the lateral. Operate the platform lifting control, make sure that the system automatically brings the frame to the horizontal position
- Lift the platform without a load to the maximum height and then lower it a few times; make sure that the machine works correctly
- Check the operation of the anti-shearing device; this can be done by lifting the platform to a height that involves an angle of the scissor frames greater than  $12^\circ$  with respect to the horizontal and make sure that the descent movement stops automatically at a scissor angle between  $7^\circ$  and  $9^\circ$  (the vertical distance between the ends of the scissors must be greater than 50mm). Further downward movements are possible only after a 3s delay at reduced speed.

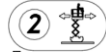

**Note:** The platform is fitted with a “crush-preventing” system (ref. Point 5.4.4 EN 280), which gets enabled when the platform lowers and temporarily blocks it to allow the operator to make sure there are no bystanders near the machine.

- Check the operation of the travel function with the platform lifted; this test is performed by lifting the platform to a height that involves an angle of the scissor frames of  $23^\circ$  with respect to the horizontal (maximum height of transit area 4.5mt) and make sure that it is possible to travel with the machine only at reduced speed (light indicator 2 flashing ). Also make sure that at greater heights the light indicator (2) turns off and that it is not allowed to move.

- Check that with the platform lifted higher than the transport height but lower than the maximum travel height (light 2 on) and moving on non-level terrain, the machine stops automatically when the inclination of the frame with respect to the horizontal exceeds 1°. Release the travel control; when this control is operated again or when the lifting control is operated, the system must bring the frame back to the horizontal position automatically. After the levelling, the machine will perform the selected movement.
- Lift the platform to a height greater than the transport height, check that the manual levelling functions are not allowed.
- Operate the emergency button on the remote control (or radio control); make sure that the engine turns off (both the internal combustion engine and the electrical engine) and that no functions are allowed. Release the mushroom-shaped button after this test.
- Operate the ground movement emergency button; make sure that the engine turns off (both the internal combustion engine and the electrical engine) and that no functions are allowed. Release the mushroom-shaped button after this test.
- Operate the warning buzzer and make sure it works.
- Check the operation of the buzzer when the travel or work platform descent functions are used.
- Make sure, with the machine travelling and the platform in the transport position (with travel selector on DM) that, when the Joysticks are released, the machine stops immediately.
- Make sure that the manual emergency descent device works properly.
- Make sure that the platform extension can move freely and that the pedal blocks it safely
- Make sure that the folding railings are correctly positioned and secured

### ***2.11 Precautions when work terminates or is interrupted***

**It is forbidden to leave the MEWP unattended without having first stopped the engine and removed the keys from the control panel to prevent the machine from being used by unauthorized persons**

## 2.12 Safety regulations during maintenance



The maintenance operations described in this Manual refer to platforms in conditions of normal use. In heavy duty use conditions (e.g. extreme temperatures, dust and corrosive substances in the environment, etc.), inform the ALMAC S.r.l. assistance services to have the maintenance intervals checked and changed.

The MAINTENANCE operations must only be performed by authorized and adequately trained personnel.

Only perform the MAINTENANCE and ADJUSTMENT operations described in this Manual. Contact the ALMAC S.r.l. assistance service only, if other operations are required (e.g. if faults occur).

All MAINTENANCE work must be performed in compliance with the laws in force governing safety and protection of the environment.

**THE MANUFACTURER IS RELIEVED FROM ALL LIABILITY FOR ACCIDENTS OR FAULTS DUE TO FAILURE TO COMPLY WITH THE RECOMMENDATIONS AND SAFETY REGULATIONS.**

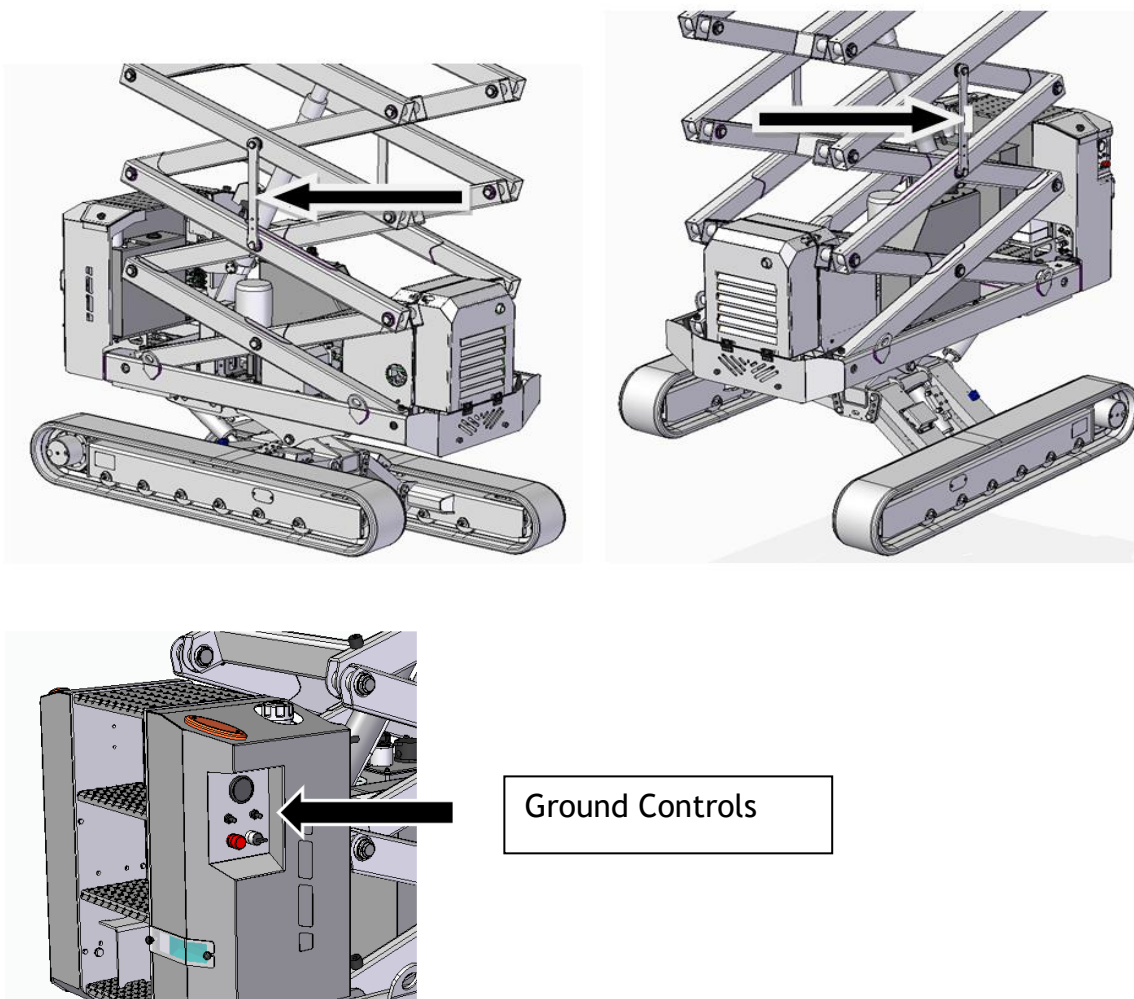

- Proceed with maintenance operations only after turning off the machine and deactivating the battery disconnect switch.
- Before proceeding with the interventions, make sure the platform is completely blocked.
- If the work platform must be raised for maintenance purposes, the platform and lifting structure must be prevented from accidentally lowering. To do this, there is a device on the lift arm that must be set in a precise position so as to immobilize the scissor structure (see procedure described below).  
The MEWP is equipped with two devices on the sides of the pantograph.  
**WARNING:** It is mandatory to position both devices before performing any operation in the machine.



The photo above shows how the locking system of the extensible structure must be positioned during maintenance work. By means of the "ground controls", it is possible to lift the work platform until it is possible to place the two locking brackets vertically and aligned with the pins below. Subsequently lower the work platform until the brackets are locked in the relative pins.

- Protect the environment: avoid spilling oil when changing it or topping up. Used oil must be disposed of in accordance with the laws in force.
- Never insert the body, limbs or fingers in sharp, jointed opening on the machine that is not controlled or without proper guards unless securely blocked.
- Do not use petrol, solvents or other flammable liquids as detergents. Always use authorized non-flammable and non-toxic commercial products



- Do not use open flames for lighting purposes when performing maintenance.
- Make sure there are no fluids under pressure before disassembling unions or pipes: oil spattering out under pressure can cause serious injuries. Immediately call a physician if injuries occur or the fluid from pipes is accidentally ingested. Remember that fluid seeping from a very tiny hole can be almost invisible but possess sufficient force to penetrate under the skin. Use a piece of card or wood to check for leaks. 
- Make sure that all parts of the hydraulic circuit have been tightened correctly
- When compressed air is used for cleaning parts, protect yourself by wearing safety goggles with side guards and limit the pressure to 2 atm maximum. (1.9 bar). 

### 2.13 Personal protective equipment (PPE)

To operate the machine in complete safety, it is required to use appropriate personal protective equipment, which must be worn before climbing onto the work platform and used as indicated.

- Safety helmet
- Safety shoes
- Protection Gloves

#### PERSONAL PROTECTION EQUIPMENT

			
Body protection required	Protective gloves required	Safety shoes required	Hearing protection required

### 3 DESCRIPTION OF THE MACHINE

#### 3.1 Structure of the equipment

This section describes the main components of the machine and their functions.



3.1.1 Work platform  
assembly

3.1.2 Scissor assembly

3.1.2 Tank and chassis  
assembly

### 3.1.1 Work platform assembly

1. Control push-button panel (console)



2. Control console emergency button



3. Glove box



4. Extensible work platform



5. Spirit level

6. Socket on work platform

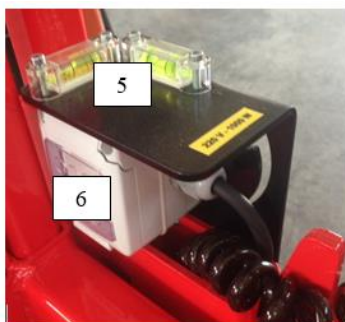

7. Device for the extension of the work platform

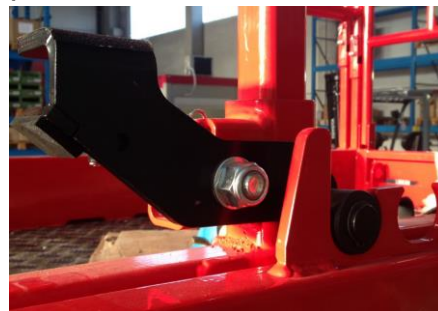

8. Device to access the work platform





### 3.1.2 Scissor assembly

9. Lifting cylinder



10. Lifting cylinder shut-off valve

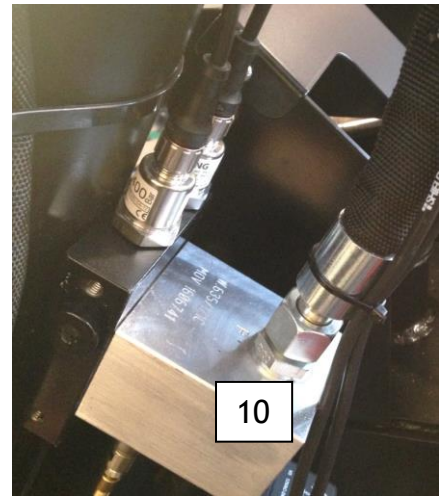

11. Pressure transducer for load control



12. Scissor angle sensor

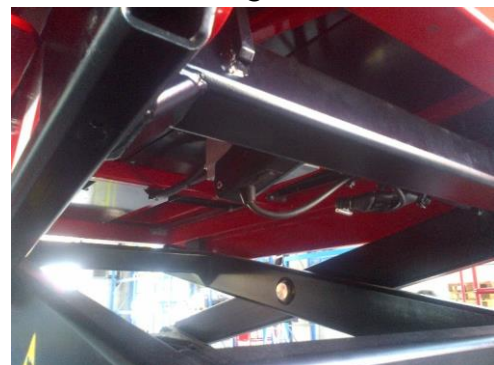

### 3.1.3 Tank assembly

13. Ladder to access the platform



14. Main hydraulic unit



15. Main differential panel



16. Ground control panel



17. Flashing light



18. Ground control panel emergency button



19. ECU electronic control unit

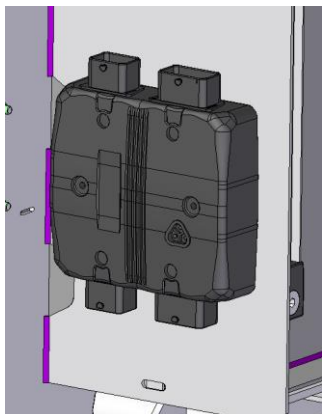

20. Battery disconnect switch



21. Emergency descent device



22. Hydraulic oil tank

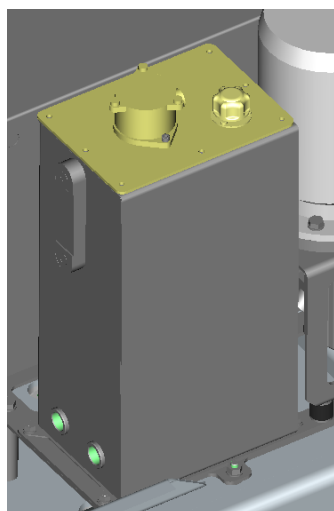

23. Discharge filter

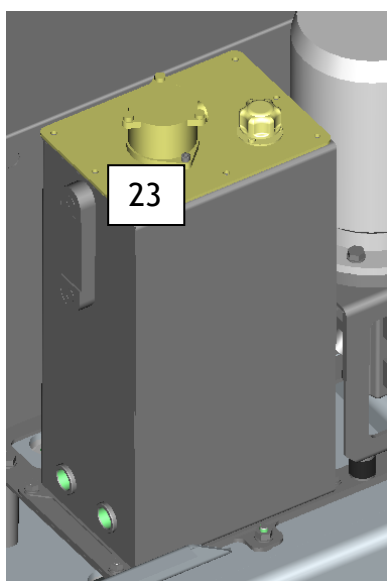

24. Intake filters (in the tank)

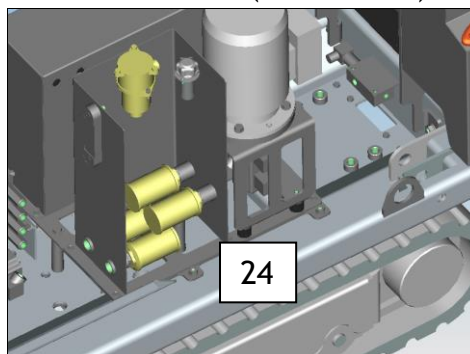

25.Oil tank refill cap

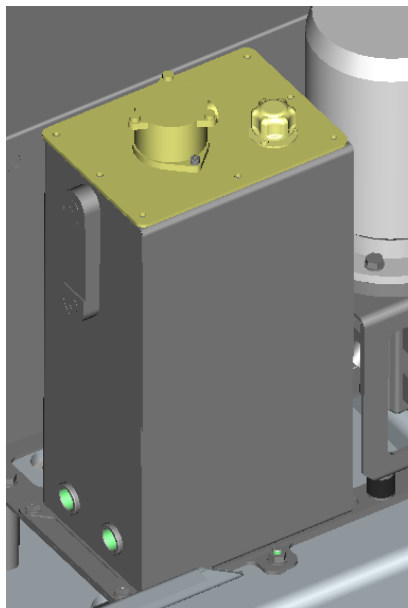

26. Visual hydraulic oil level

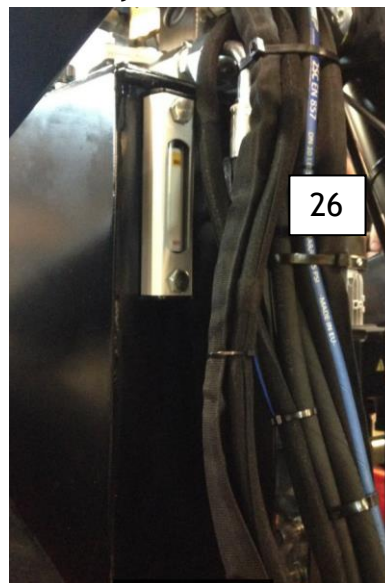

27.Combustion engine starter battery



28.Booster for management of third travel speed

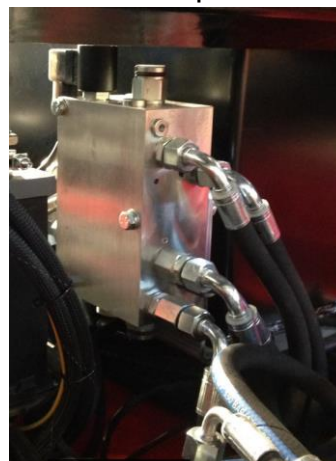

29.Electrical engine

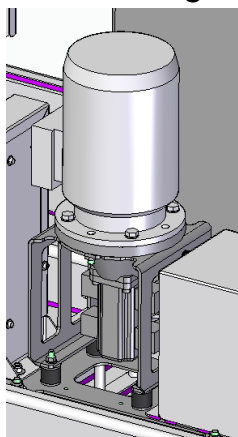

30.Inverter differential panel (if present)



31. Frame angle sensor



32. "Proactive levelling" angle sensor

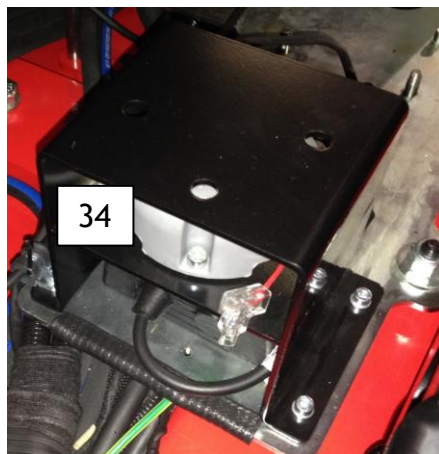

33. "Proactive levelling" safety valves

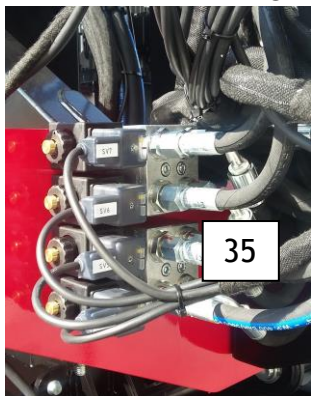

34. "Proactive levelling" limit switch

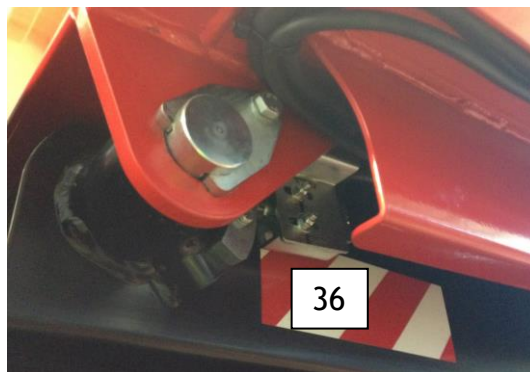

35. Combustion engine

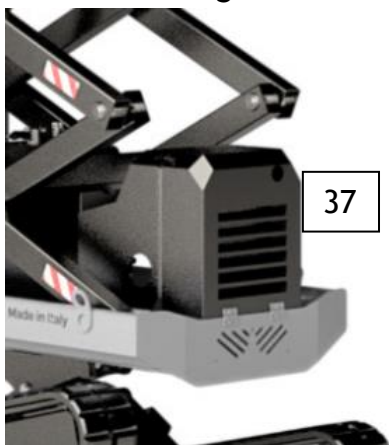

36. Fuel tank

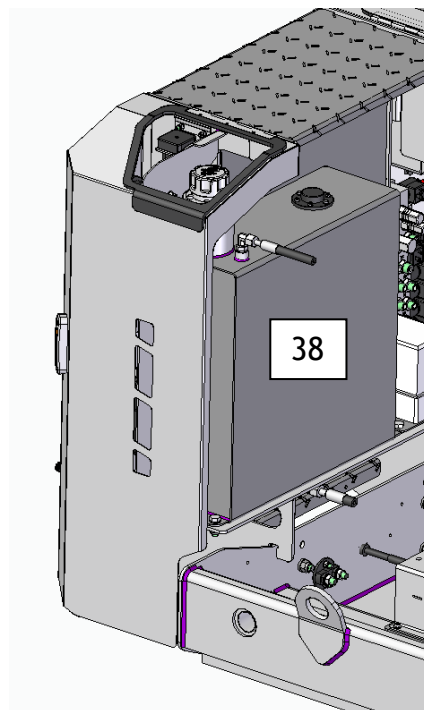

37. Bi-levelling chassis



### 3.2 Control stations

#### 3.2.1 Mobile control push-button panel (console)

The platform is equipped with a mobile control push-button panel (console) which allows for normal operation on the work platform.

The console can be located in the dedicated metal support attached to the railing of the platform or removed and held by the operator.



Even the metal support can be removed by unscrewing the special knob.

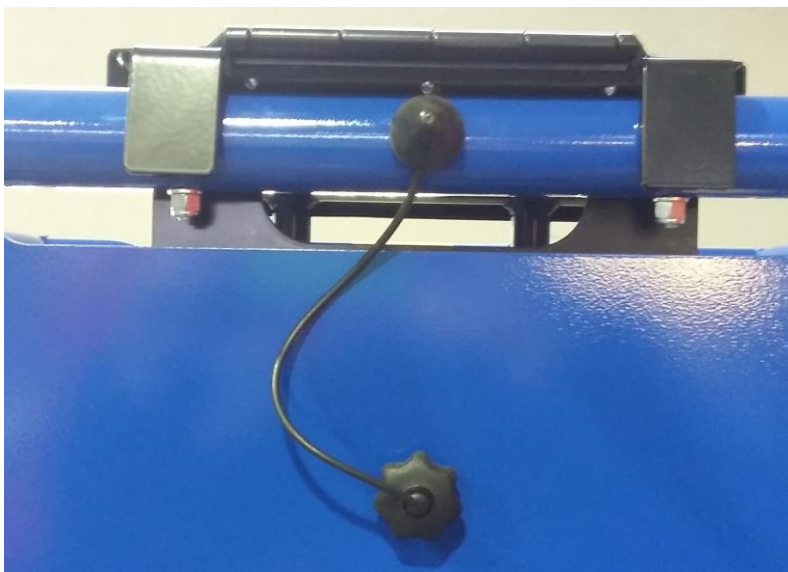

Warning: If the platform is transported on vehicles, always secure the support by means of the threaded knob.

The push-button panel can also be disconnected from the spiral cable by unscrewing the ferrule indicated with A.

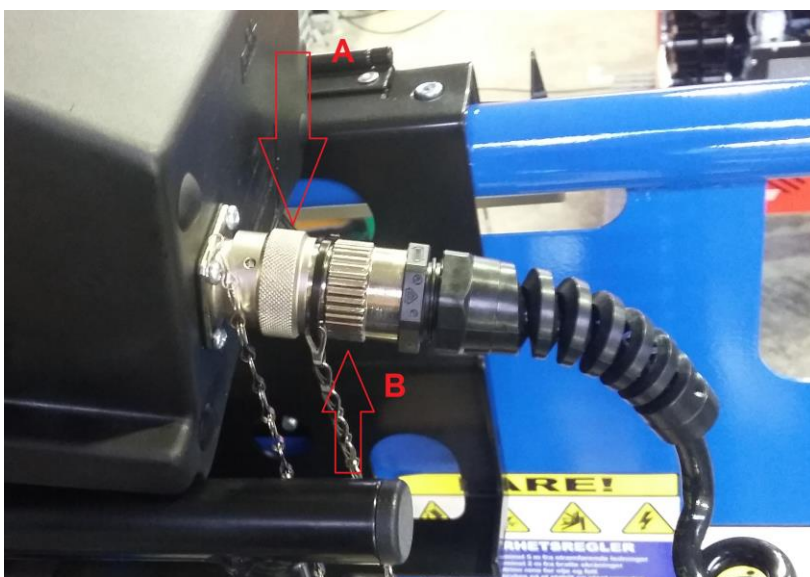

Warning: Do not touch ferrule B; if ferrule B is turned, the wires inside the connector will be damaged.

The push-button panel can be placed in a compartment closed with a locked hatch and located on the left side of the access ladder.



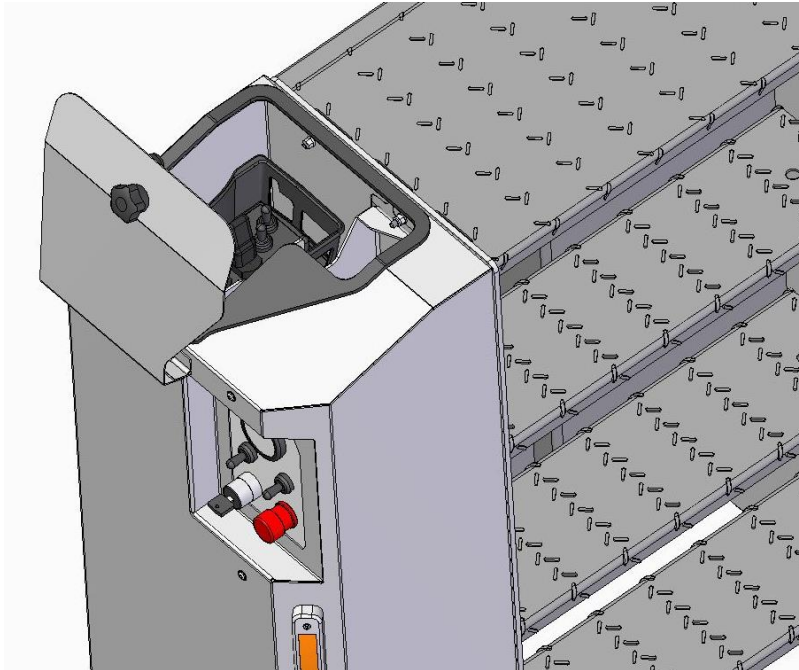

Warning: For all operations that required lifting the work platform above the transport height, the console and the operator must be inside the platform itself.

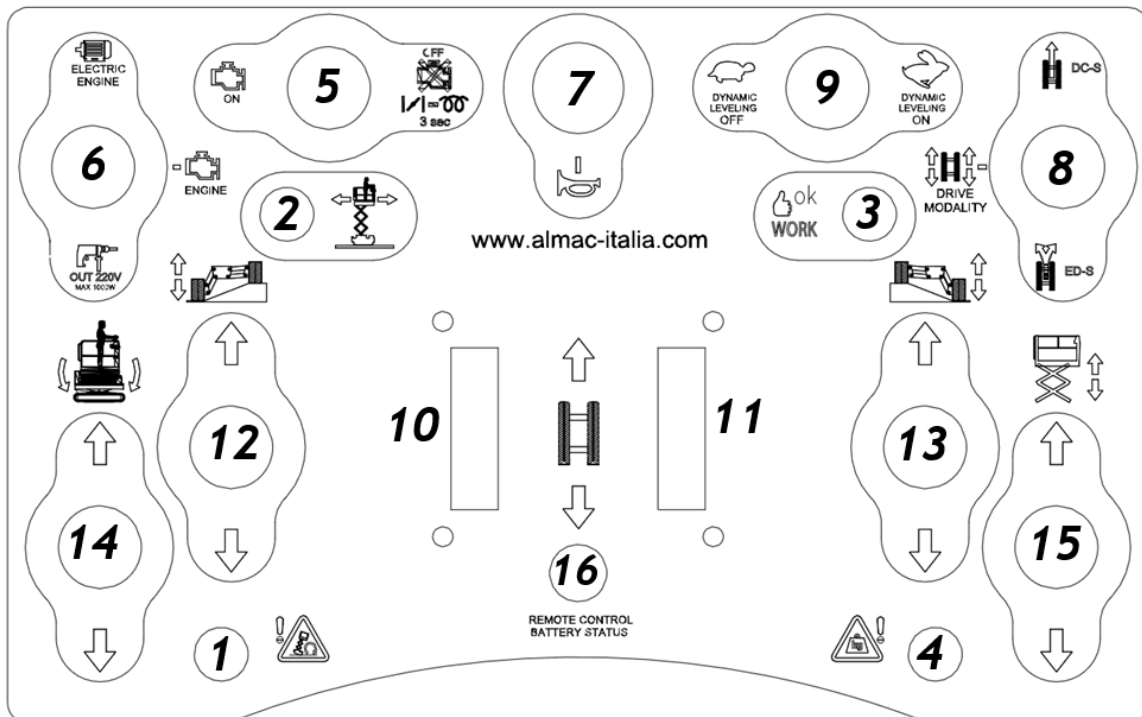



	Identification	Function and Status	Description of the function
1	Indicator light	<b>PLANARITY ALARM</b> (with indicator light 3 on)	
		OFF	Lateral inclination $0^\circ < 0.5^\circ$ Longitudinal inclination $0^\circ < 0.5^\circ$
		<b>FLASHING</b> (If the platform does not exceed the maximum allowed transit height)	Lateral inclination $> 0.5^\circ < 3^\circ$ Longitudinal inclination $> 0.5^\circ < 3^\circ$
		<b>ON</b> (If the platform does not exceed the maximum allowed transit height)	Lateral inclination $> 3^\circ$ Longitudinal inclination $> 3^\circ$
		<b>ON</b> (If the platform exceeds the maximum allowed transit height)	Lateral inclination $> 0.5^\circ$ Longitudinal inclination $> 0.5^\circ$
		<b>TRAVEL ENABLING</b> (with indicator light 3 on)	
2	Indicator light	OFF	Travel not allowed, proactive levelling allowed (if $< 4.5\text{mt}$ )
		FLASHING	Travel and proactive levelling allowed but at the height limit
		ON	Travel and proactive levelling allowed
3	Indicator light	<b>WORK ENABLING</b>	
		OFF	Machine without the controls enabled
		ON	Machine with the controls enabled
4	Indicator light	<b>OVERLOAD ALARM</b>	

	Identification	Function and Status	Description of the function
		OFF	Load in work platform between 0 and 260Kg (1.2 nominal load)
		On	Load in work platform greater than or equal to 260Kg (1.2 nominal load); the normal operation of the platform is prevented
5	Selector switch	ENGINE ON / OFF	
			<p>To turn on the combustion engine, select ON.</p> <p>To turn off the combustion engine, select OFF.</p> <p>By selecting OFF and holding the command for 10 seconds, the glow plugs will be activated.</p>
6	Selector switch	SELECT ELECTRICAL ENGINE / GENERATOR (IF PRESENT)	
		ENGINE position	<p>Standard operation with internal combustion engine.</p> <p>On the work platform, the 230V outlet is not powered unless the plug under the ladder has been connected to an external power source.</p>
		ELECTRICAL ENGINE position	<p>Turning the internal combustion engine off and enabling the electrical engine.</p> <p>To turn on the electrical engine, it is necessary to turn selector 5 ON.</p> <p>The electrical engine works only if the plug under ladder has been connected to an external power source. The outlet on the work platform is powered.</p>
		Position OUT 220	<p>Standard operation with internal combustion engine.</p> <p>By turning the selector switch to this position, the current source is activated (if present) to have 22V in the outlet on the work platform without having to connect the plug under the ladder to an external power source.</p> <p>The internal combustion engine operates at an accelerated rate</p>
7	Button	WARNING BUZZER	

	Identification	Function and Status	Description of the function
		<b>DRIVING MODE SELECTOR</b>	
8	Selector switch	CENTRAL position	Standard operation - traction FORWARD/REVERSE enabled using 2 joysticks
		DC-S position	Simultaneous movement FORWARD/REVERSE of the tracks with the RH joystick only (11)
		ED-S position	Easy Drive System assisted drive control system
		<b>TRAVEL SPEED SELECTOR</b>	
9	Selector switch	TURTLE position	Low speed for all movements + Dynamic levelling OFF
		HARE position	High speed for all movements + Dynamic levelling ON
10	LH joystick		Left track FORWARD/REVERSE travel control
11	RH joystick		Right track FORWARD/REVERSE travel control
12	Selector switch		Left levelling
13	Selector switch		Right levelling
14	Selector switch		Longitudinal levelling
15	Selector switch		Ascent / descent
16	Indicator light	REMOTE CONTROL BATTERY STATUS INDICATOR (if present)	
17	Emergency Button	EMERGENCY STOP	

### 3.2.2 Ground control using the mobile push-button panel

With the mobile control push-button panel, as well as allowing for the normal operation of the work platform, it is possible to temporarily remove and use the machine from the ground.

This is allowed only for travel operations with the work platform at a height lower than the transport height.



Prior to carrying out the operation make sure the platform is brought into the transport position, that is completely lowered.

Once the push-button panel has been removed from its housing on the work platform, have it firmly secured to the operator's body using a shoulder strap to avoid incorrect manoeuvres.



During this operation, be careful not to come into contact with the platform tracks. Stay at a safe distance using the length of the spiral cable.

Once the transport phase is over, place back the push-button in its original seat.

### 3.2.3 Ground controls

The platform features a control console located on the chassis at the back of the machine. These controls are useful for the operator on the ground for platform maintenance or for emergency situations (red mushroom button).

The ground controls are protected against unauthorized use by a key that is used to activate the 3 way switch.

Warning: The key must always be available to the recovery operator or the person in charge of the operations from the ground.

The Involuntary activation of the ground controls is inhibited thanks to the automatic selection performed by the key: by turning it to "work platform controls" (RIGHT), it automatically disables the ground control console while the "ground controls" position (LEFT) automatically disables the control console.

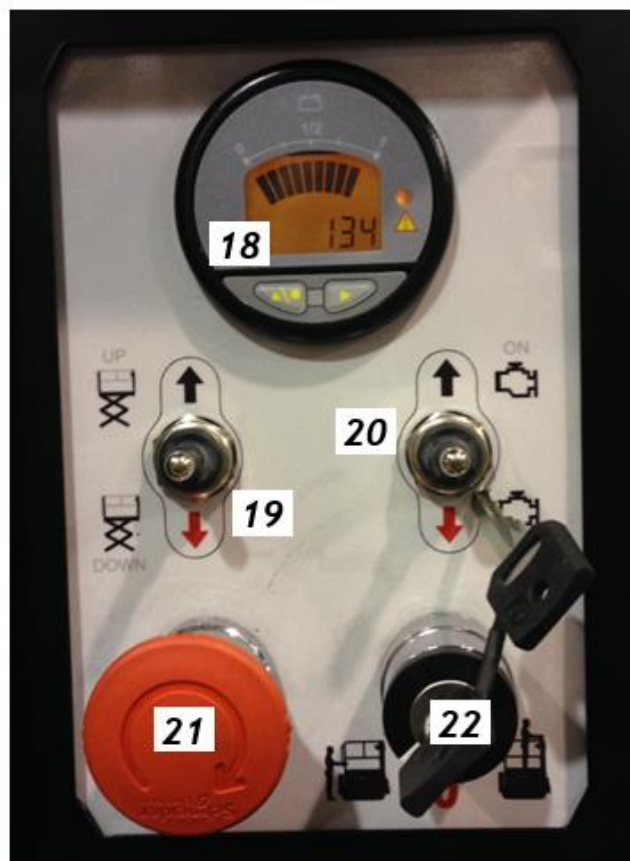

	Identification	Function and Status	Description of the function
18	Display	Display of the hours of operation and machine status, with an indication of any alarms.	
19	Selector switch	PLATFORM UP / DOWN SELECTOR	
			To control the upward movement of the work platform, move the selector UP
20	Selector switch		To control the downward movement of the work platform, move the selector DOWN
		ENGINE ON / OFF	
20	Selector switch		To turn on the engine, move the selector to the ON position
			To turn off the engine, move the selector to the OFF position
21	Emergency Button	EMERGENCY STOP	
22	Key selector	MACHINE ON / OFF SELECT CONTROL STATION	
		CENTRAL position	Machine off
		LH position (operator on the ground)	Ground controls selection (it is only possible to turn the engine on/off and to move the work platform up/down)
	RH position (operator on work platform)	Selection of controls on work platform (all controls are enabled)	



Warning: only personnel who have been properly trained and skilled in using the controls may use the ground controls.

IT IS FORBIDDEN to stay inside the work platform while another operator performs manoeuvres with the ground controls.

### ***3.3 Storage compartment***

On the platform, under the control console, there is a compartment, which can be opened by hand. It contains:

- This Use and Maintenance Manual
- The spare parts catalogue
- Wiring diagrams
- Hydraulic diagrams
- Declaration of conformity
- Engine manual



Personal objects can also be stored in the compartment, so long as they are of a suitable size.



### 3.4 Platform operation safety devices



Warning: Periodically verify that the safety devices are operating correctly. During work, the operator must be able to assess, recognize and avoid all dangers and must immediately inform the persons in charge of any faults in the safety devices so that they can be inspected and restored to their original conditions of safety and reliability

**DO NOT TAMPER WITH AND DO NOT CHANGE THE CALIBRATION OF ANY OF THE COMPONENTS OF THE ELECTRICAL AND HYDRAULIC SYSTEM.**

The platform comprises a complete set of safety devices.

#### 3.4.1 Main frame inclination control device

On the machine Frame there is a Can Bus angle sensor that constantly communicates the inclination measured to the electronic control unit.

The angle sensor is redundant (thus consisting of two separate sensors) and the X and Y inclination axes of the machine are monitored (lateral and longitudinal)

The signals of the two sensors are constantly compared with each other to assess their consistency.

The device is placed under a cover positioned inside the scissors.

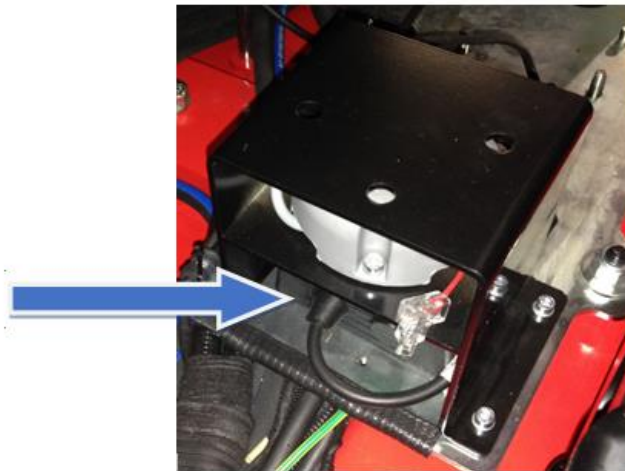

#### 3.4.2 Frame and height inclination redundant control device

On the platform, there is an additional angle sensor which provides a 12V output signal if the frame is within the limit value of 3°.



This sensor is connected in parallel to the limit switch that controls that the platform is at a height lower than the transport height (the 12V output signal is interrupted if the platform is lifted above the transport height).

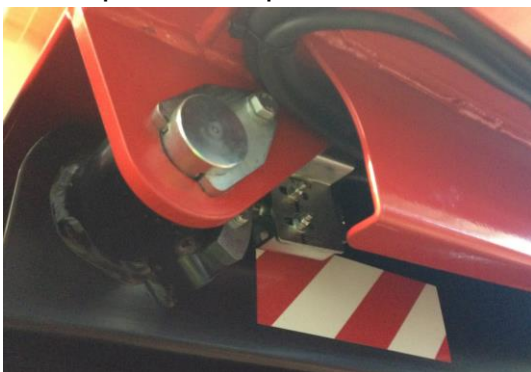

These devices are part of another electromechanical safety ring that prevents the movements of the machine, disabling the outputs of the control unit and disconnecting the other block valves on the levelling cylinders.

Versione distributore MOVECO  
Versione KUBOTA  
Versione Bi Energy  
Con possibilità radio

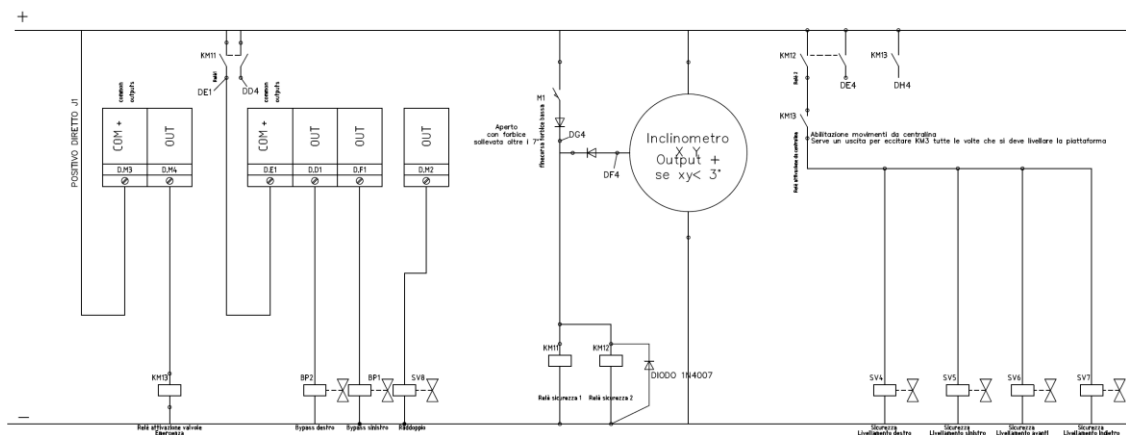

The limit switch and the relays are monitored by the control unit, which generates an alarm if a fault is detected.

If the limit switch malfunctions, the Proactive levelling function is disabled.

If the relays malfunction (bonding), the entire operation of the machine, except for the downward movement, is disabled.

### 3.4.3 Work platform height control device

On the upper frame of the scissors, directly under the work platform, there is a Can Bus angle sensor that constantly communicates the inclination measured to the electronic control unit.

The angle sensor is redundant (thus consisting of two separate sensors) and the Y inclination axis of the scissor frame is monitored (longitudinal)

The signals of the two sensors are constantly compared with each other to assess their consistency.

The values of the two sensors are constantly compared with the Y values of the sensors attached to the frame.

By measuring their difference, it is possible to establish the height of the work platform compared to the completely lowered position (relative angle between scissors and frame  $4^\circ$ ).



### 3.4.4 Load limiting device

The machine is equipped with a work platform that, once extended, has a surface area greater than 1 m<sup>2</sup>.

For this reason, on the cylinder there are two pressure transducers which, with the angle sensors of the frame and of the scissors, make up a system able to detect whether the load on the work platform exceeds the nominal load by 20%.

If an overload condition is detected at any height above the transport height, all the movements of the work platform are prevented; they will be re-enabled only if the excess load is removed.



**DANGER:**

- NEVER OVERLOAD THE MACHINE OVER THE LIMIT SET BY THE MANUFACTURER.
- THE OPERATOR MUST NOT MOVE BETWEEN THE WORK PLATFORM AND A STRUCTURE OUTSIDE THE MACHINE; THE MACHINE MAY BECOME UNSTABLE.

### 3.5 Hydraulic system safety devices

#### 3.5.1 Hydraulic pressure limiting devices

The hydraulic system of the platform features special general maximum pressure valves (1-2) in order to limit the pressures relating to the operation of the machine, preserving the integrity of the various components.

These valves need no adjustments since they are calibrated by ALMAC S.r.l. when the machine is tested. The diagram below illustrates the integrated power pack and the position of the pressure relief valves described above.

The integrated hydraulic power pack also includes a pressure relief valve for the lifting circuit (3). This provides additional safety, besides the overload monitoring device installed, to prevent the machine from being overloaded.

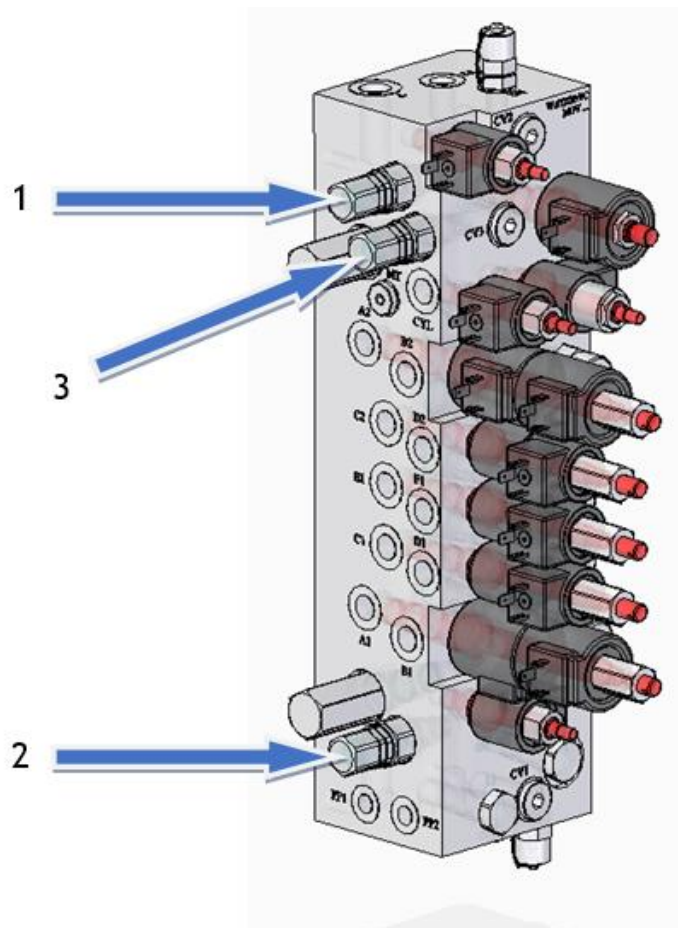

1. Maximum system pressure valve : set to 210 bar
2. Maximum system pressure valve : set to 210 bar
3. Maximum lifting pressure valve : set to 160 bar



Warning: modifications to the positions of the maximum pressure valves without authorization from ALMAC S.r.l. will void the warranty and any claims made by the customer.

### 3.5.2 Hydraulic block safety devices

The hydraulic block features three solenoid valves with possible manual by-pass. These solenoid valves, indicated with 1-2-3, are part of the safety system of the machine and **must never be operated manually.**

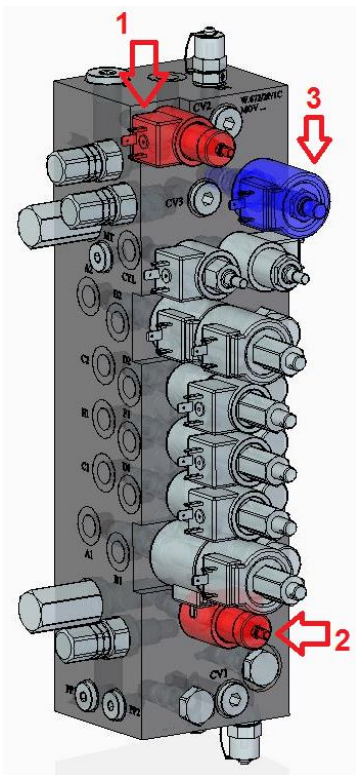

**WARNING: If valve 3 is not in the fully activated position by pressing and turning clockwise (you will hear a click) and valves 1-2 are unscrewed and locked with a seal, the safety of the machine is compromised and the platform may overturn.**

### 3.5.3 Hydraulic failure safety devices

The hydraulic system of the lifting circuit, in the event that there is an accidental fault in the hydraulic piping that feeds the lifting cylinder of the work platform, features a one-way valve, normally closed (1), electrically DRIVEN and connected directly to the cylinder, which prevents the uncontrolled descent of the work platform from any height, thus avoiding dangerous situations. This valve also features a WIRE EMERGENCY CONTROL (2), to be used in case of emergency. (ref. Section 5.10.2 UNI EN280:2015):

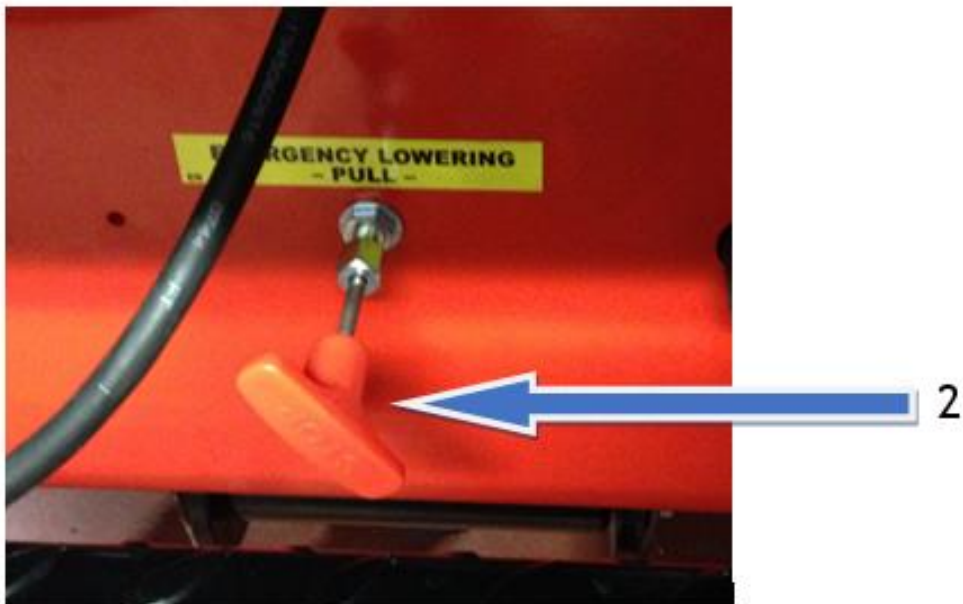
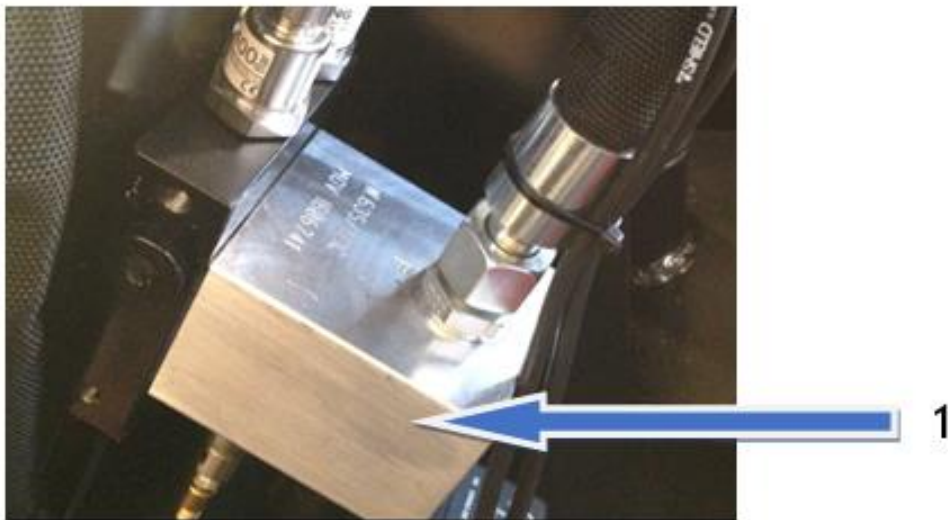

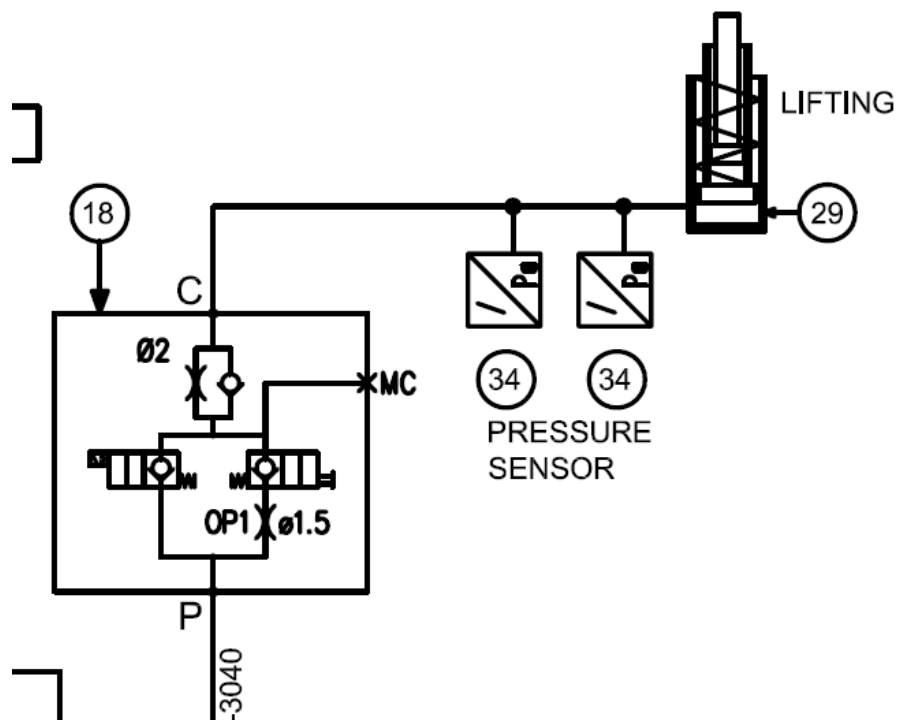

Proceed as described below to restore the machine to normal operating conditions:

1. Repair the damaged hydraulic hose and/or connections
2. Fill and bleed the hydraulic circuit
3. Lift the platform to its maximum height

If the hydraulic hoses that supply the track chassis levelling cylinders malfunction and suddenly change the track and the inclination, dedicated BALANCING VALVES prevent the track from moving suddenly (ref. Section 5.10.2 EN280).





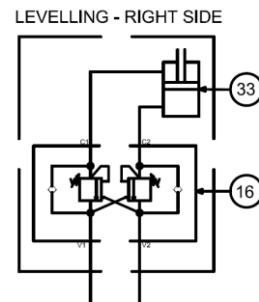
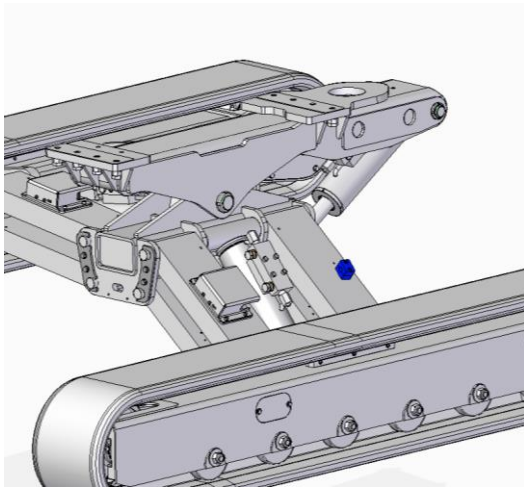

If one of the balancing valves malfunctions (fault not provided for in UNI EN 280:2015), there are 4 normally closed valves placed on each of the dangerous movements of the cylinders of the chassis. These valves are fed (kept open) only if the chassis is inclined in the two axes by an angle lower than  $3^\circ$ , or if the platform is below the transport height.

The system that controls the power supply is separated from the main one and connected to an angle sensor and dedicated limit switch.

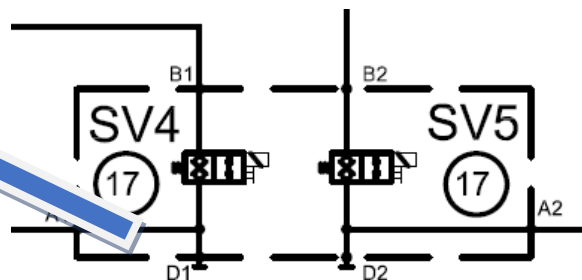
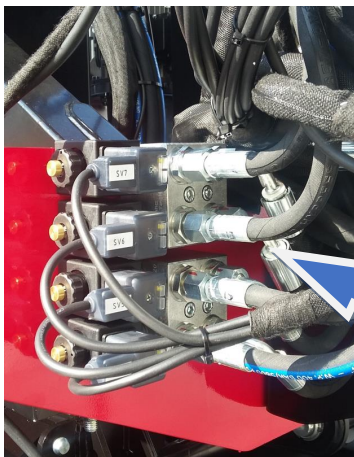

These valves are blocked in the normally closed position by means of lead wire. Proceed as described below to restore the machine to normal operating conditions:

1. Repair the damaged hydraulic hose and/or connections
2. Fill and bleed the hydraulic circuit
3. Manually perform the lateral and longitudinal levelling

### 3.6 Blackout safety devices

#### 3.6.1 230V external power source

On the work platform there is a power socket to supply the power tools required during work. For safety reasons, a device is installed so as to cut-out the electricity supply in case of over-voltage and "differential circuit breaker" dispersions (1).

To access the device, it is necessary to unscrew the dedicated knobs on the cover itself, removing the transparent protection panel (2) and open the electrical box cover. When finished, replace the guard that was previously removed and thoroughly tighten the knobs.

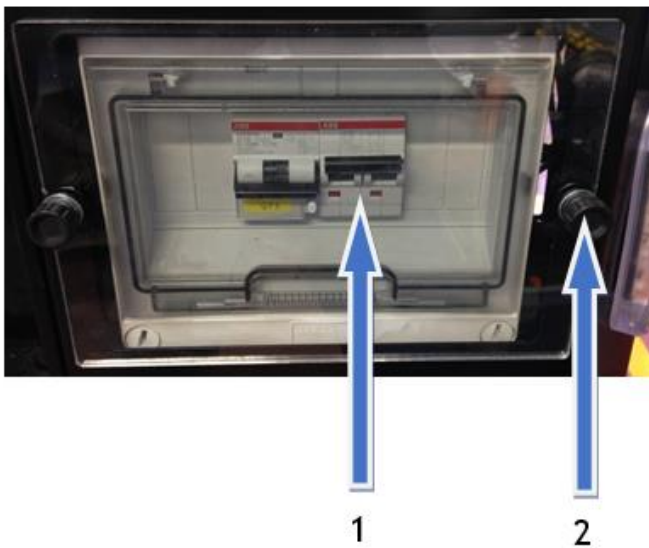

The power outlet on the work platform is also controlled by a switch (4) that allows the operator to disconnect its power supply.

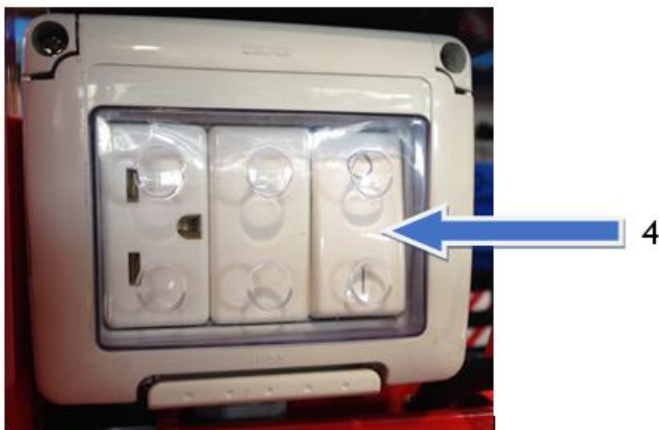

### 3.6.2 220V inverter (optional)

If the machine is equipped with a 220V inverter to power the outlet on the work platform, the following safety devices will also be present:

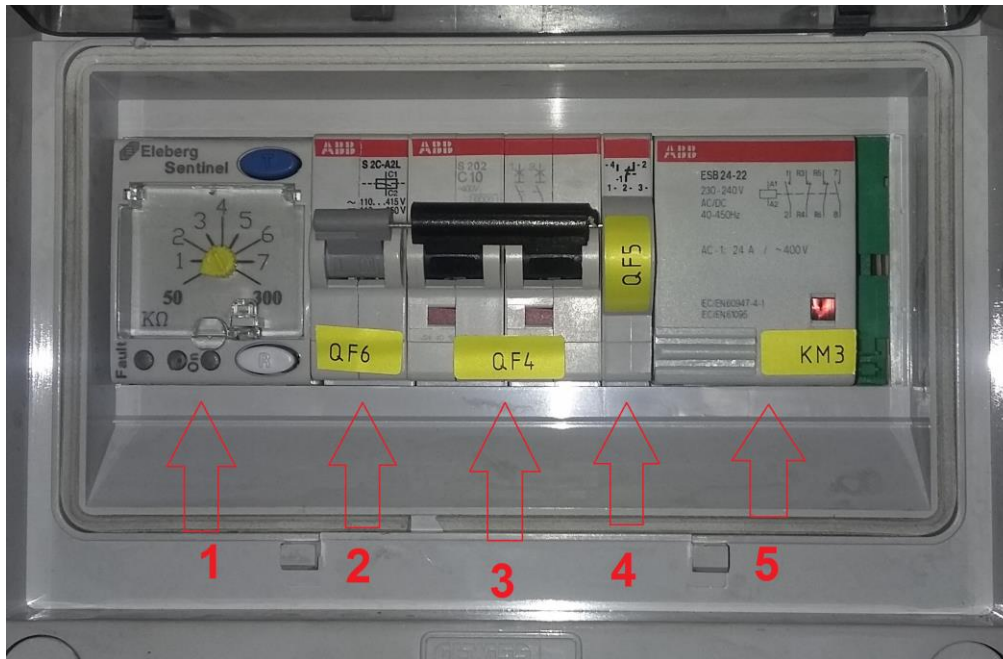

- 1) Insulation control device between the cables that go from the inverter to the outlet on the work platform and the machine frame (Sentinel)
- 2) Trip coil (triggered in the event of an alarm from the sentinel)
- 3) Circuit breaker
- 4) Auxiliary contact for insulation failure alarm (an alarm is generated if the Sentinel has triggered the trip coil)
- 5) Exchange relay that switches the platform outlet connection from then inverter to the plug placed under the ladder. The exchange occurs automatically when 230V is detected on the plug.

### 3.6.3 12V system

Near the access ladder is the "battery isolator" (3) which physically disconnects the 12v electric line coming from the battery supplying the various users.

It is recommended to operate this device at the end of the work day, to prevent draining the batteries.

Near the access ladder and the life-saving devices there are also security fuses to protect the 12V electrical equipment.

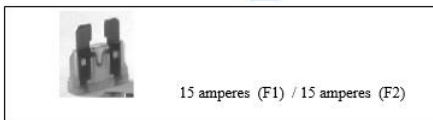

### ***3.7 Platform operation devices which are not part of the safety system***

On both connecting rod assemblies (right and left) connecting the tracked chassis and the central frame, there are two Can Bus angle sensors.

The angle sensors are redundant (thus consisting of two separate sensors) and monitor the X inclination axis of the respective connecting rod.

The values of the two sensors are constantly compared with the X values of the sensors attached to the frame.

By measuring their difference, it is possible to determine the relative position of the connecting rod with respect to the frame.

The position of the two connecting rods is used by the control unit to decide which one should be moved during the lateral levelling operations (according to the X axis).

Since neither the travel height nor the operating height depend on the position of the connecting rods, they are not part of the safety system but only of the system required for the operation of the machine.

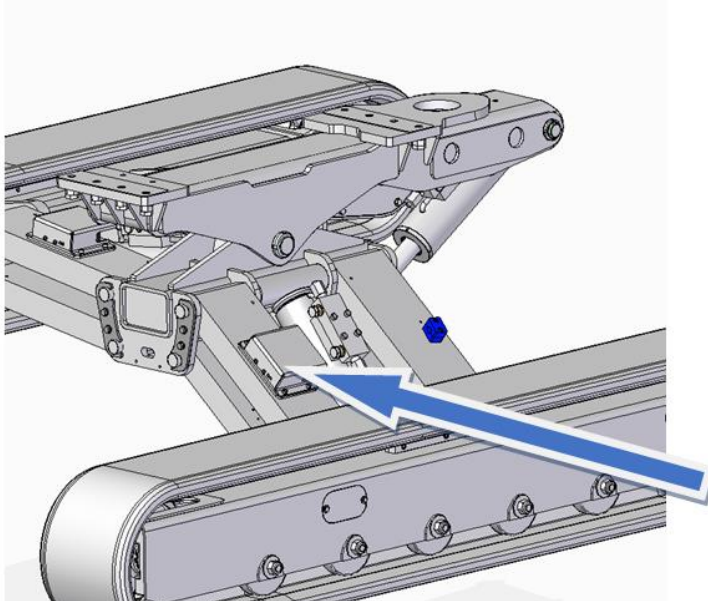

### 3.8 *Foot pedal*



The pedal in the basket is used as a safety system that is:

- **Free pedal:** the machine can only move with the basket completely lowered (transportation position), all other movements are inhibited;
- **Pedal pressed:** all movements are enabled.

## 4 Instructions for use

### 4.1 Preliminary operations

#### 4.1.1 Suitability of the soil

To assess whether the ground is fit to bear the machine, it is extremely important to ensure that the ground surface does not allow the machine to slip once it has been stopped for work.

Two factors contribute towards increasing the danger of slipping:

- Slope
- Poor grip (or slipperiness) due to a low friction coefficient

These two factors must be assessed with the utmost care, and at the same time as each other. There are no acceptable values for one "factor" that can exclude the risk of slipping if the other factor is extremely unfavourable. Ground that is almost flat may not be fit if its surface is icy. On the other hand, a surface with high adhesion may not be fit if it slopes too steeply.

Flat, horizontal ground is the ideal surface for work platform stability, even though this condition is very rare.

- Avoid smooth, slippery and/or icy surfaces and those covered with sand: they could cause a risk of sliding or tipping during levelling.

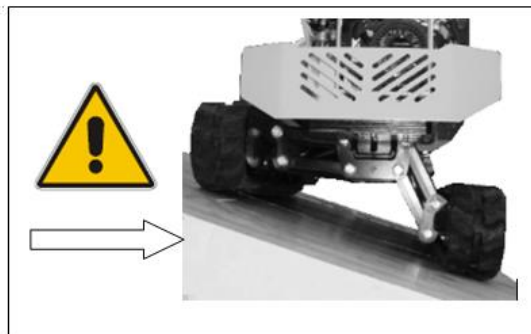

- NO ICE!
- NO SAND!
- NO DUST OR SMOOTH SURFACES!



**Note:** Do not use the MEWP if you are doubtful about the fitness of the ground surface.

- After having levelled it, lift the work platform only after making sure, both visually and by moving inside the work platform, that all 4 ends of the tracks rest on the ground.

Avoid the following situation for both tracks:



The ring gear of the wheel drive units and the track tensioner wheels must all be resting on the ground.

If even one of them is not in contact with the ground, the stabiliser area will be reduced and, consequently, the platform will be unstable and there will be the risk of overturning.



#### 4.1.2 Action of the wind

It is forbidden to use the machine if the wind speed exceeds 12.5 m/s.

The following chart describes the consequences of different wind speeds (Beaufort scale).

Scale of the Italian Hydrographic Service			Beaufort International Scale				Effects
N°	Wind description	Speed in km/h	N°	Wind description	Corresponding speed		
					In km/h	In m/sec	
0	Calm	0-7	0	Perfect calm	1,08 3,60	0,3 1,0	Calm, smoke rises vertically
			1	Light air, bora	6,12 7,20	1,7 2,0	Wind direction shown by smoke but not by wind vanes
1	Light wind	7-14	2	Light breeze	11,16 14,40	3,1 4,0	Wind felt on face; leaves rustle; vane moved by wind
2	Moderate breeze	14-29	3	Light wind	17,28 21,60	4,8 6,0	Leaves and small twigs in constant motion. Wind extends flags.
			4	Moderate breeze	24,12 28,80	6,7 8,0	Wind raises dust and leaves. Branches are moved.
3	Almost strong breeze	29-36	5	Fresh breeze	31,68 36,00	8,8 10,0	Small bushes begin to sway. Waves form with white foam crests.
4	Strong breeze	36-50	6	Strong breeze	38,52 43,20	10,7 12,0	Large branches in motion.
			7	Near gale	46,44 50,40	12,9 14,0	Whole trees in motion.
5	Gale	50-83	8	Gale	55,44 61,20	15,4 17,0	Wind breaks branches off trees; difficulty in walking against the wind.
			9	Strong gale	64,80 72,00	18,0 20,0	Structural damage (chimney-pots and slates removed)
			10	Storm	75,60 82,80	21,0 23,0	Trees uprooted. Serious structural damage.
6	Hurricane	83-108	11	Violent storm	86,40 108,00	24,0 30,0	Widespread damage.
	Not classified		12	Hurricane	144,0 180,0	40,0 50,0	Countryside is devastated



Danger: The platform must never be used when wind speed corresponds to a value greater than 6 of the Beaufort scale.

Work must be performed with the utmost warning with wind speeds between 4 and 6 of the scale.

#### **4.1.3 Access to the work platform**

The work platform must only be accessed with the platform completely LOWERED.

To make it easier for the operator to access the platform, it is advisable to use the Easy Access function.

To take position at the controls, use the ladder (1) provided until reaching the last step.

Then, grabbing the railing (2) firmly with one hand, enable the "release lever" (3) and manually open the access gate.

Once you have climbed onto the work platform, the gate will return to its initial position and lock itself automatically to prevent the operators from falling from heights.

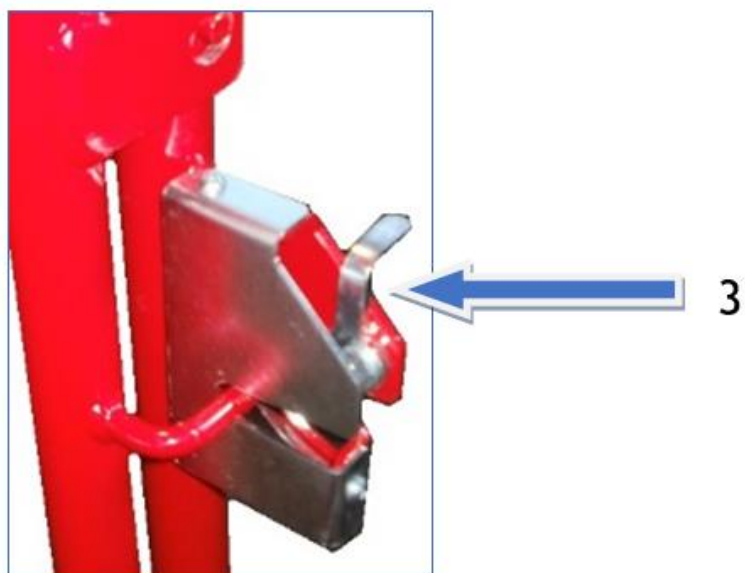
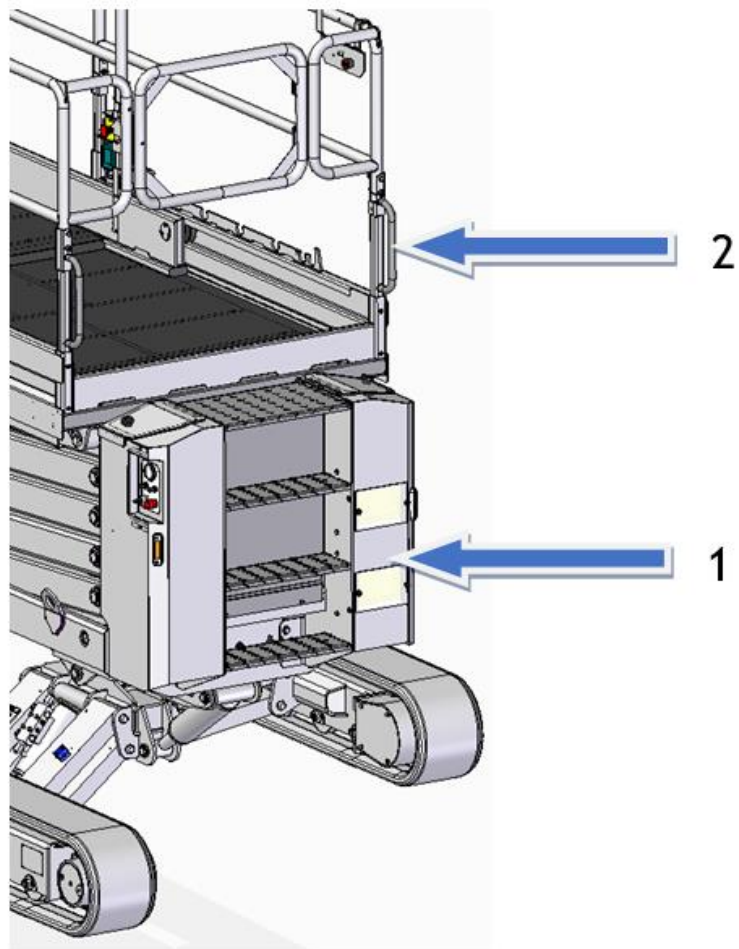

Warning: IT IS FORBIDDEN to block the gate in such a way as to keep access to the platform open.

#### 4.1.3.1 Easy-Access system to facilitate access to the work platform

A system that allows the operator to place the machine in such a way that it is easier to climb up the ladder to access the work platform.

With the platform completely lowered, repeatedly operate twice "work platform down"; in this way, the machine will automatically widen the tracks and tilt backwards (see below).

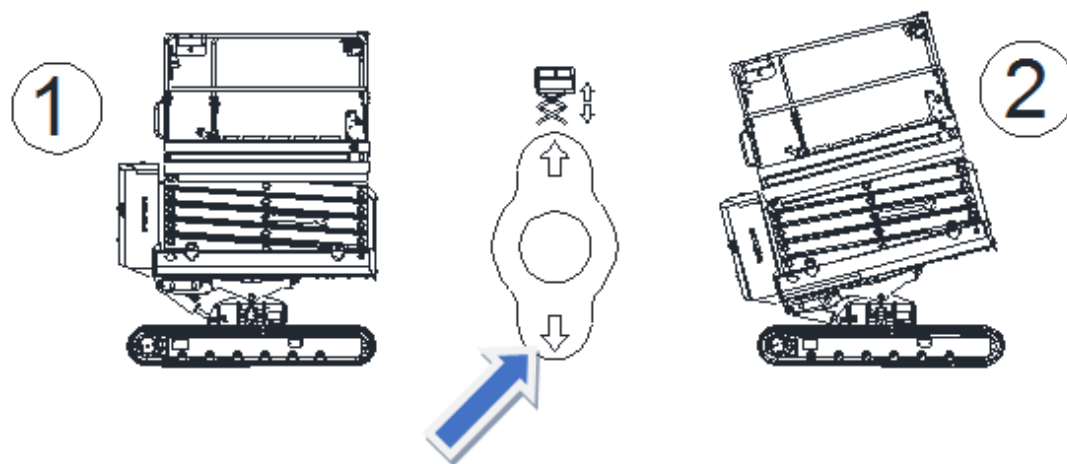

#### 4.1.4 Work platform extension

The work platform is provided with a driven mechanism that enables to further extend the work area so as to reach more distant parts. To extend the work platform, it is necessary to:

1. Push the unlocking pedal (A)
2. Push the work platform floor manually by grasping it by the railings (B) beyond the minimum dimensions.
3. Make sure that the pin of the pedal is locked in one of the available seats (C)
4. To shrink back the platform, carry out the same operations in reversed order.

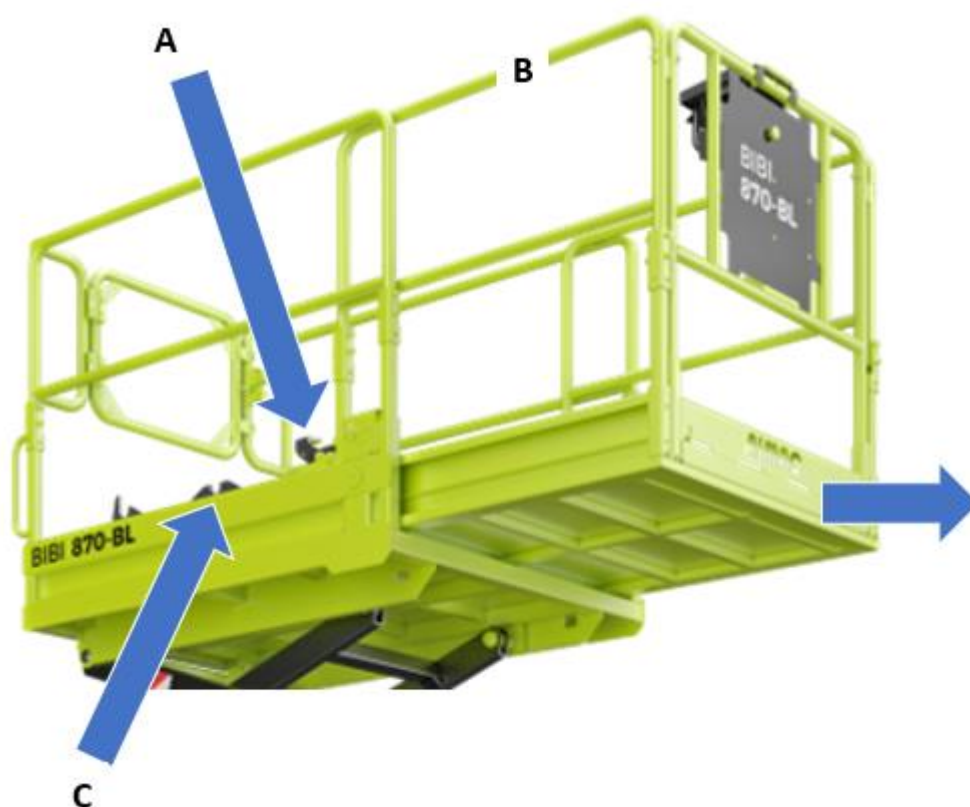

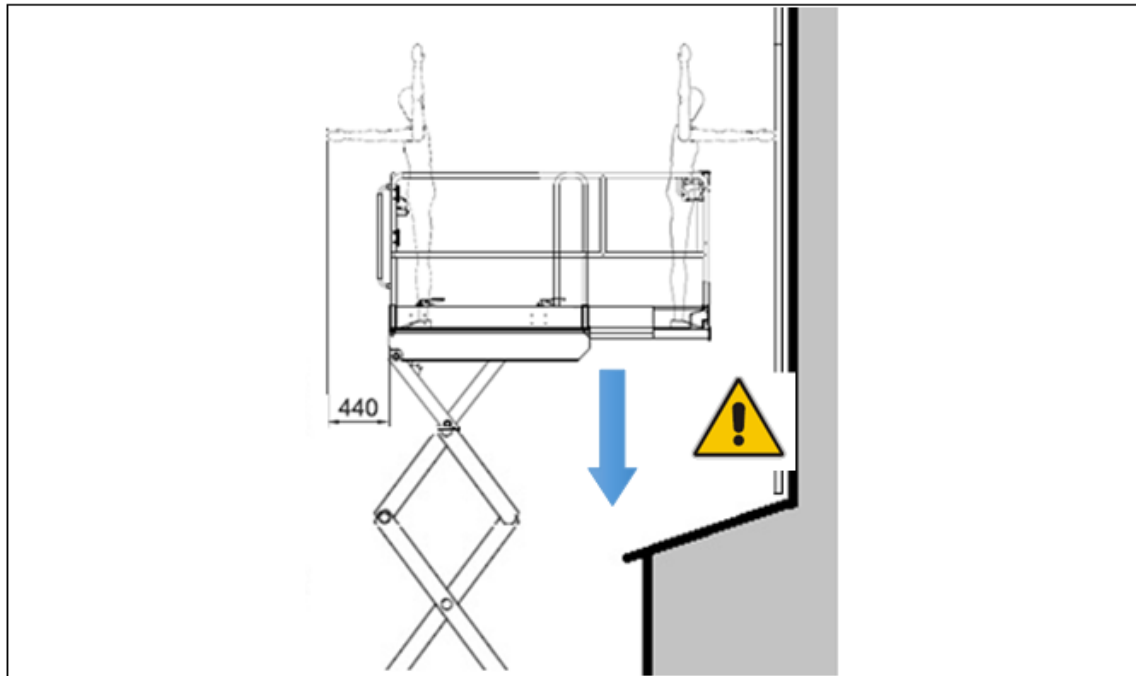

Warning: while descending from the working position, pay warning to possible obstacles beneath the work platform to prevent the platform from overturning or being damaged!

### 4.1.5 Checking the fuel level

Before turning on the engine and/or starting a work shift, it is advisable to check the fuel level.

The fuel level is visible in the ground control area (1).

There is also a reserve sensor (2). If the fuel level is too low, the machine will emit an acoustic signal, the FUEL alarm will appear on the display and after 15 seconds the engine will turn off to avoid emptying the fuel system completely.

Top up the fuel by means of the dedicated filler cap (3).

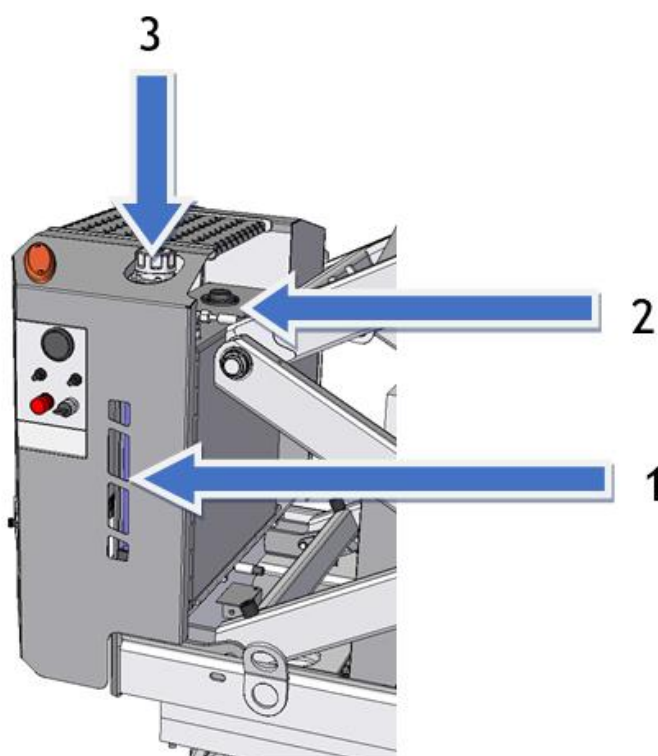

- The minimum recommended cetane number of the fuel is 45. It is preferable to have a cetane number higher than 50, especially for ambient temperatures below  $-20^{\circ}\text{C}$  or for altitudes above 1500 mt.
- The specific type of diesel fuel and sulphur content in % (ppm) must comply with the applicable emission standards for the area in which the engine is used.
- It is strongly recommended to use fuel with a sulphur content below 0.1% (1000 ppm).
- Fuels with an EN590 or ASTM D975 specification are recommended.
- For more information, consult the use and maintenance manual of the engine.

#### 4.1.6 Checking the oil level in the engine

Check the engine oil level before starting it, or when more than 5 minutes have gone by after stopping it.

Pull out the oil level indicator, clean it by wiping it and reinsert it.

Pull the oil level indicator out again and check.

For more information, consult the use and maintenance manual of the engine.

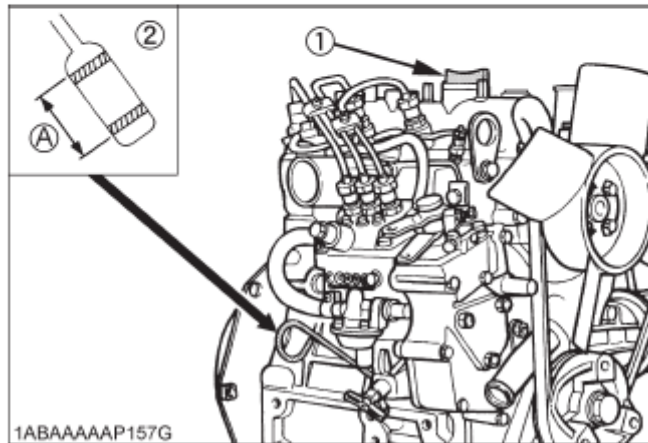

#### 4.1.7 Folding the railings

The platform is provided with folding railings which facilitate the transport and the passage inside vehicles. To perform the folding, unlock the pins located on every railing according to a pre-determine sequence.

1		<ul style="list-style-type: none"> <li>• Extend the work platform according to the instructions given in sect. 4.1.4 <i>Extending the work platform</i> until it has been fully extended</li> </ul>
2		<ul style="list-style-type: none"> <li>• Standing within the security of the outer rails;</li> <li>• Unlock the fastenings of the front railing (see following pages);</li> <li>• Fold the railing according to the figure (the rail is not possible to fold outwards even when unlocked);</li> <li>• This is possible without removing the controller cradle from the end panel.</li> </ul>

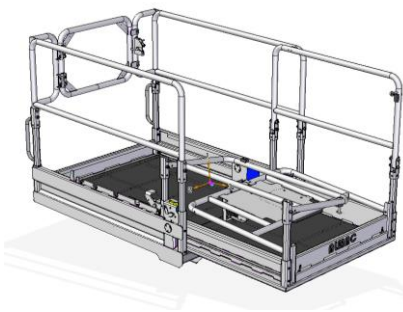
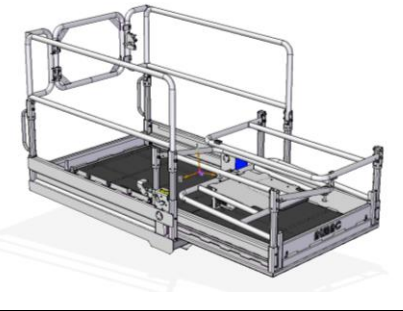
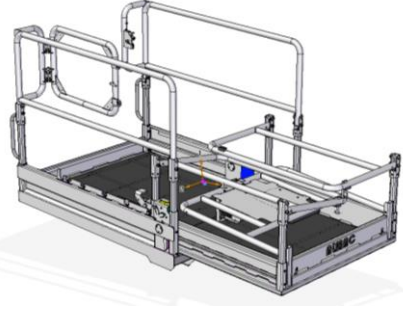
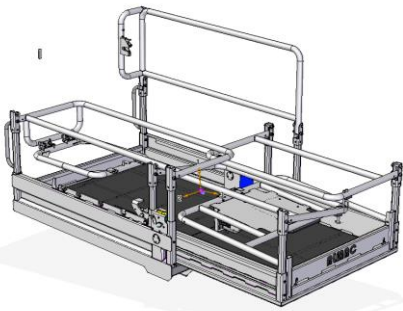
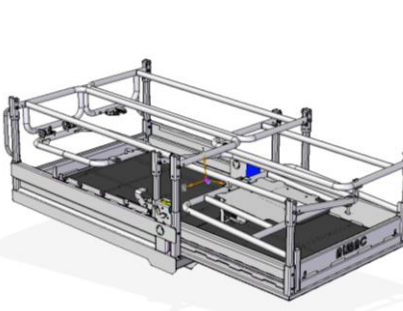

3		<ul style="list-style-type: none"> <li>• Unlock the fastenings of the expandable basket RH railing</li> <li>• Fold the railing according to the figure</li> <li>• Exit the platform before folding the outer rails</li> </ul>
4		<ul style="list-style-type: none"> <li>• Unlock the fastenings of the LH railing of the expandable work platform</li> <li>• Fold the railing according to the figure</li> </ul>
5		<ul style="list-style-type: none"> <li>• Open the access gate according to the picture</li> </ul>
6		<ul style="list-style-type: none"> <li>• Unlock the fastenings of the RH railing of the work platform</li> <li>• Fold the railing according to the figure</li> </ul>
7		<ul style="list-style-type: none"> <li>• Unlock the fastenings of the - LH railing of the work platform</li> <li>• Fold the railing according to the figure</li> <li>• In this configuration, it is possible to pass through the gates with a height below 2 m.</li> </ul>

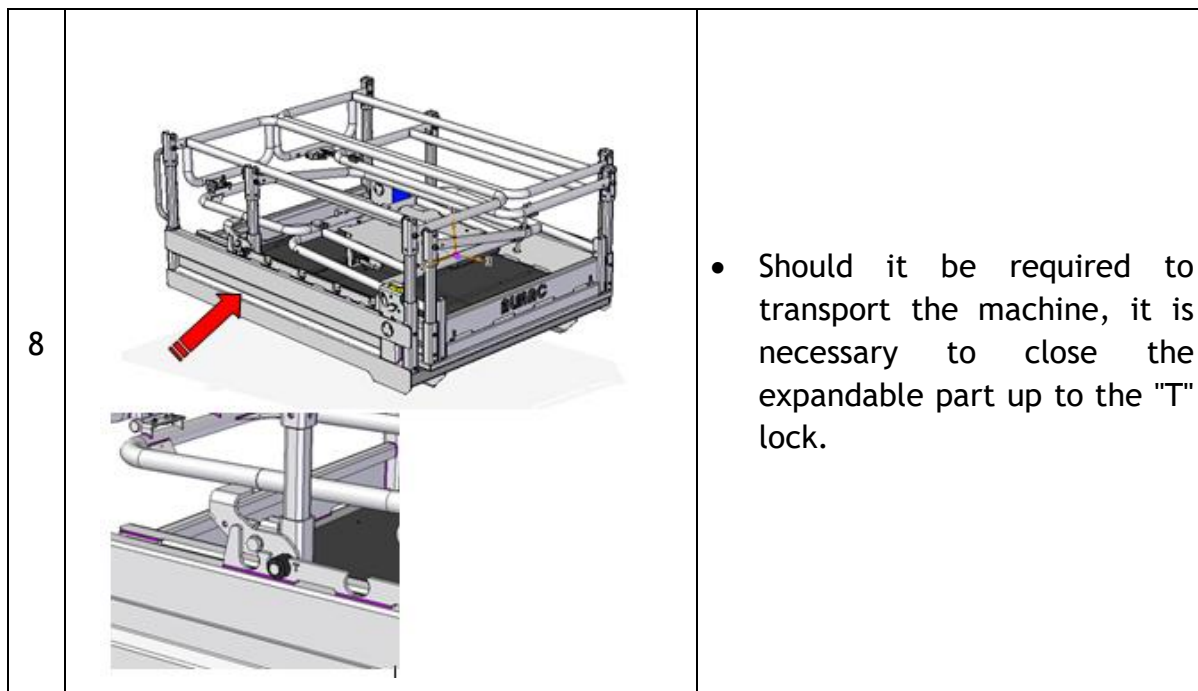

### Unlocking the railing fastenings

To unlock the railing fastenings, it is necessary to:

- 1) Turn the safety catch (A) of the locking pin (B) and then pull it from its seat
- 2) Remove the safety screw (C)
- 3) Once you have extracted all fastenings of the railings, is possible to fold it according to the instructions in the previous pages

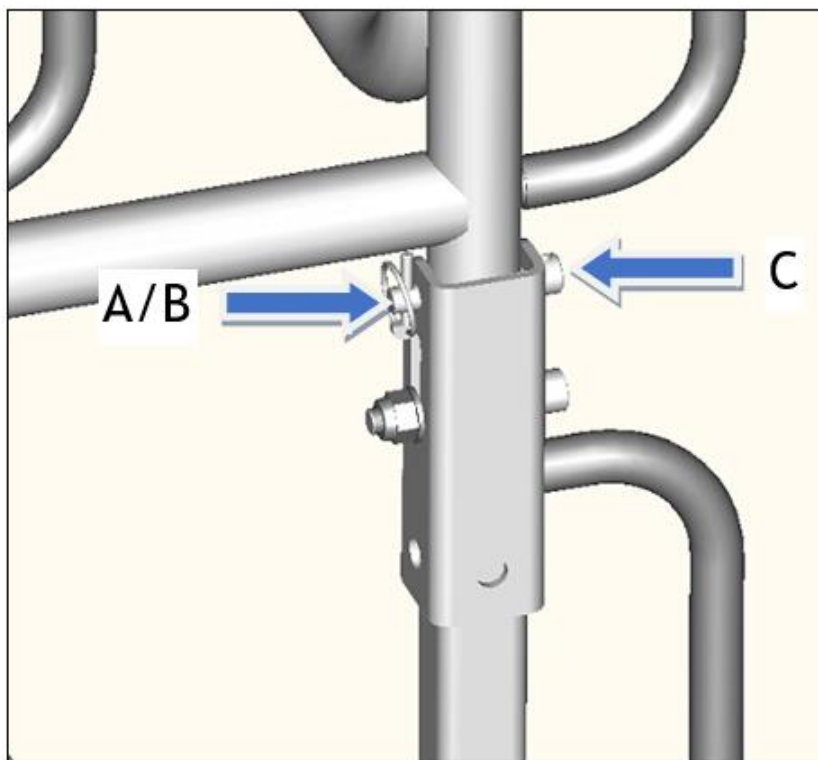

Before stepping on the platform, it is absolutely mandatory to put all the railings back in the vertical position and secure them as shown in the figure.

## 4.2 Machine operation

### 4.2.1 Starting the internal combustion engine

To start the internal combustion engine and the hydraulic pumps, use the ignition key on the ground controls.



The key-switch functions are:

- (CENTRAL): Machine off - electrical system not powered
- (RH POSITION): The whole electrical system of the platform starts, including the mobile push-button panel in the work platform. The ground controls are excluded.
- (LH POSITION): The whole electrical system of the platform starts. The ground controls are automatically enabled and the push-button panel in the work platform is disabled.

Then the control unit will begin to check the safety systems:

- On the console, the lights 1-2-3-4 will turn on, together with a beeping sound
- The lights will flash
- Once the check is complete and the machine is in the transport position and levelled, only the lights 2-3 must stay on and the beeping must stop.

Once the check-control cycle has terminated, the engine can be started:

- Turn selector no.5 to the right (OFF) holding it in place for 10 seconds (if necessary); this will activate the glow plugs
- After 10 seconds, you will hear a beep; at this point turn the selector to the left (ON).



### 4.2.2 Starting the current source

During operation with the INTERNAL COMBUSTION ENGINE, it is possible to turn the selector (6) to the OUT 220V position. In this way, it will be possible to use the 220V power in the outlet on the work platform (only for machines with inverter).

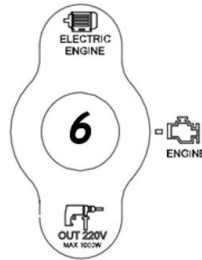

### 4.2.3 Starting the electrical engine

To start the electrical engine and thus the related hydraulic pumps, first connect a sufficiently long cable with three-pole socket that complies with European standard IEC 309 (see photo below) to the socket located near the access ladder.



The power supply characteristics of the electrical network must be compared with the characteristics of the electrical engine installed.

Characteristics of the electrical power supply network:

- Voltage: 230 v  $\pm$  10%
- Frequency: 50 Hz
- Grounding line working and equipped with a differential circuit breaker
- Use an extension power cord with an appropriate section depending on its length



Warning: the connection to a network that does not meet the requirements of the electrical engine may cause serious damage to some of the components of the machine. The machine features electrical components (contactors and differential circuit breakers) that disconnect the power to the engine and to the system.

To start the electrical engine, and thus the hydraulic pumps, use the ignition key placed on the ground controls (this part is the same as described in the paragraph "Starting the internal combustion engine").

Once this phase is complete, turn the switch (6) on the push-button to the "ELECTRIC ENGINE" position. This enables the ignition of the electrical engine and the 220V power supply to the outlet on the work platform.

To start or stop the electrical engine, select the "ON" lever (5) on the console:

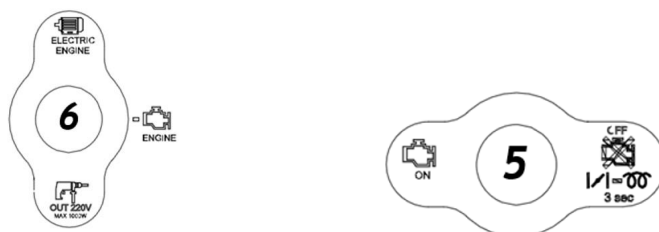

#### 4.2.4 Travel controls

The controls used for the movement of the platform are represented by 2 joysticks (10-11) located on the control panel. (see photo below).

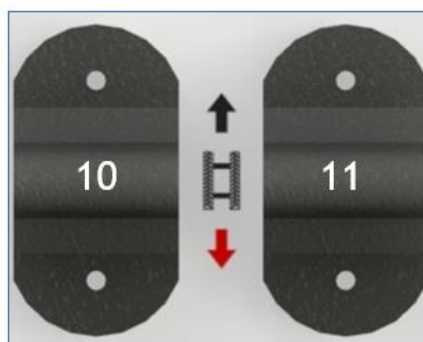

Each lever controls the respective track (right lever → right track, left lever → left track).

Move the lever forwards to drive the platform forwards. Move the lever backwards to drive in reverse.

You can work with one track at a time, depending on the movement required at that particular moment.

The translation comply with the maximum safety speed allowed by the technical regulations in force (point 5.3.1.11, UNI EN280:2015).

The platform is fitted with a tracked chassis with dual speed gear motors equipped with a negative brake, therefore the machine will remain blocked whenever the forward or backward movement is interrupted

To turn the platform, move the levers as indicated in the following illustrations.

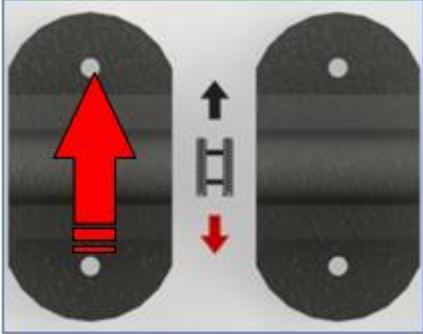
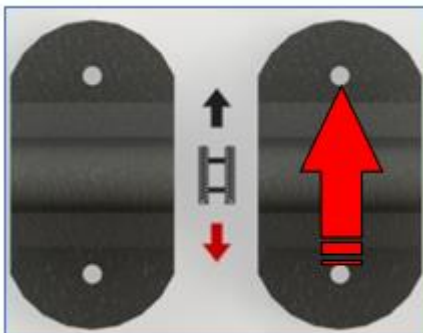
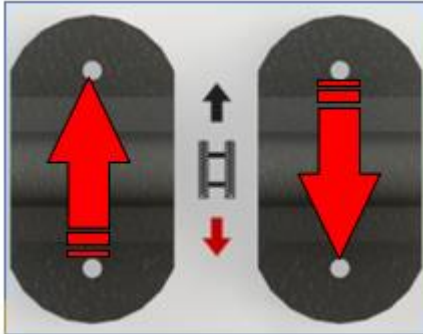
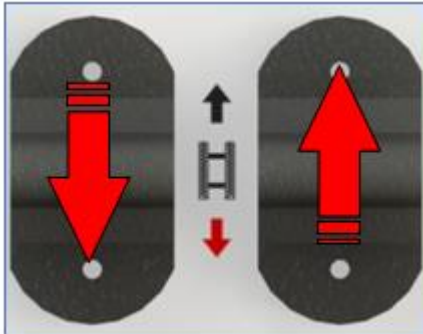
	Right turn
	Left turn
	Rotation on itself towards the right (counter-rotation)
	Rotation on itself towards the left (counter-rotation)

Travel is enabled or disabled depending on the status of the travel approval light located on the control panel. It provides the following information:

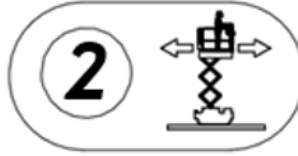

- On: travel allowed up to a maximum height of 4.5 m platform floor, proactive levelling active
- Flashing: travel allowed up to a maximum height of 4.5 m platform floor, proactive levelling active, but at the limit of the maximum height allowed
- Off: travel not allowed



**WARNING:** If you must drive up a slope, do not change direction when the ground changes from flat to sloping. If this is absolutely necessary, perform the manoeuvre gradually.



It is forbidden to climb on the tracks to attempt any operation that is not allowed or to use the controls on the work platform.

It is forbidden to climb on the tracks when the machine is moving.







It is forbidden to travel above the transport height in the following conditions:

- Wet ground
- Snowy and/or icy ground
- Dry asphalt but covered with sand, gravel or other aggregates

Warning: slipping hazard!

#### 4.2.4.1 Standard travel mode

With selector 8 on the central position “DRIVE MODALITY”, it is possible to perform all the travel movements separately (see paragraph 4.2.1).

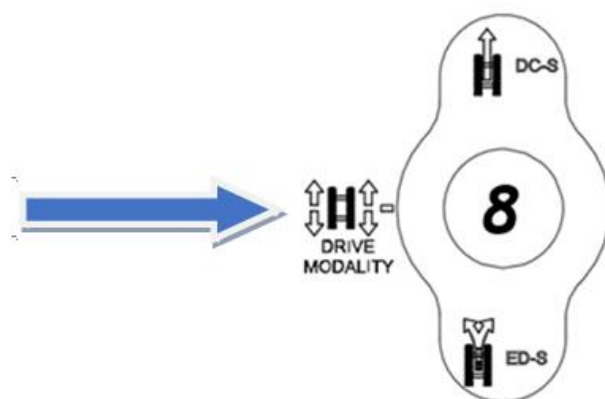

#### Adjusting the speed:

This is possible using selector 9 on the console that controls the internal combustion engine accelerator.

Turtle: engine idling

Hare: engine at accelerated rate

(If the electrical engine is selected, there is no speed variation)



#### 4.2.4.2 Easy-Drive System (ED-S)

Moving the selector 8 on the push-button panel to the "ED-S" position activates a special function that allows you to control the rotation of the platform, especially when operating on cultivated or grassy terrain, so that the tracks do not rip the cultivation during the manoeuvre.

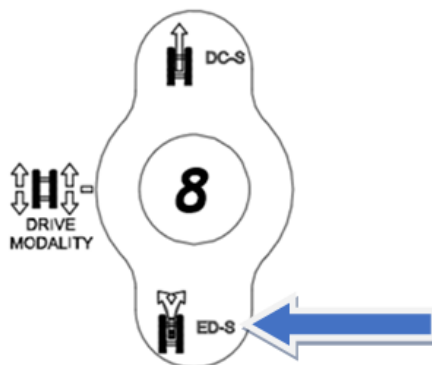

In fact, the activated function controls, in addition to the selected track, also the movement of the other track but at a lower speed.

This allows for controlled steering.

When this function is selected, counter-rotation is not enabled.

##### Adjusting the speed:

This is possible using selector 9 on the console that controls the internal combustion engine accelerator.

Turtle: engine idling

Hare: engine at accelerated rate

(If the electrical engine is selected, there is no speed variation)

#### 4.2.4.3 Direct-Control System (DC-S)

By moving the selector on the push-button panel to the "DC-S" position, you can use only the right Joystick (11) to move in the driving direction, maintaining a straight trajectory without having to correct the direction with the other joystick.

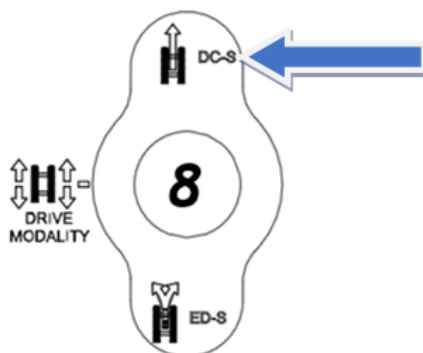

#### Adjusting the speed:

This is possible using selector 9 on the console that controls the internal combustion engine accelerator.

#### **4.2.4.4 Turtle**

In this particular travel mode, the internal combustion engine operates at accelerated rate.

This allows to have the correct power for the platform to climb up slopes and for the machine to be loaded onto vehicles.

#### **4.2.4.5 Hare**

In this particular travel mode, as well as having the internal combustion engine operating at accelerated rate, the following functions are also activated (if the electrical engine has been selected there is no variation of the number of revs but the following function is the same):

##### Capacity variation of the hydraulic engines:

The hydraulic engines use smaller capacities allowing for the speed to be increased (but at the expense of traction)

##### Booster:

After a delay of 1 second from the start of the control, the hydraulic engines are connected in series resulting in the speed doubling.

To use this function in the best way, it is advisable to control both Joysticks in the desired direction first) with selector 9 on hare) and then move selector 8 from DM to DC-S.

At this point it is possible to release the left joystick and to keep holding only the right one. The machine will continue to move straight at maximum speed.

Warning: It is not possible to perform the reverse procedure; once the machine travels in DC-S it cannot go back to DM, not even if selector 8 is moved.

It is only possible to stop the machine completely by releasing the right joystick.

Warning: When the joystick is released, the machine will not stop immediately but there is a deceleration ramp. The space travelled before it stops can even be of 50 cm.

Warning: When the joystick is released, the machine will not stop immediately but there is a deceleration ramp. The space travelled before it stops can even be of 50 cm.

#### 4.2.4.6 Travel mode with the work platform above the transport height

With the platform raised above the transport height, the maximum travel speed is automatically limited to a maximum value of 0.4Km/h.

All the functions remain the same as with the platform in the transport configuration.

Only the Direct-Control System (DC-S) function is different; in this case neither the capacity variation of the hydraulic engines nor the booster will be activated.

#### 4.2.5 Levelling the platform

The platform is equipped with an automatic levelling system with hydraulic cylinders to allow for the work platform to operate within the maximum inclination allowed, thus allowing to keep the work platform always horizontal with respect to the ground within a range of  $\pm 0.5^\circ$ , both longitudinally (longitudinal cylinder) and laterally (connecting rod cylinders).

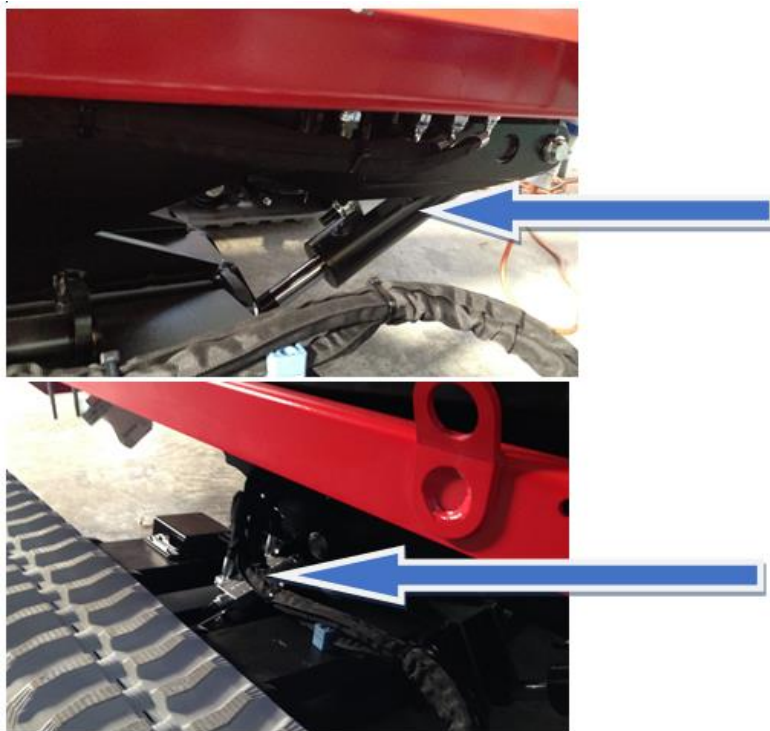

The maximum level configurations envisaged for the tracked chassis are shown below.

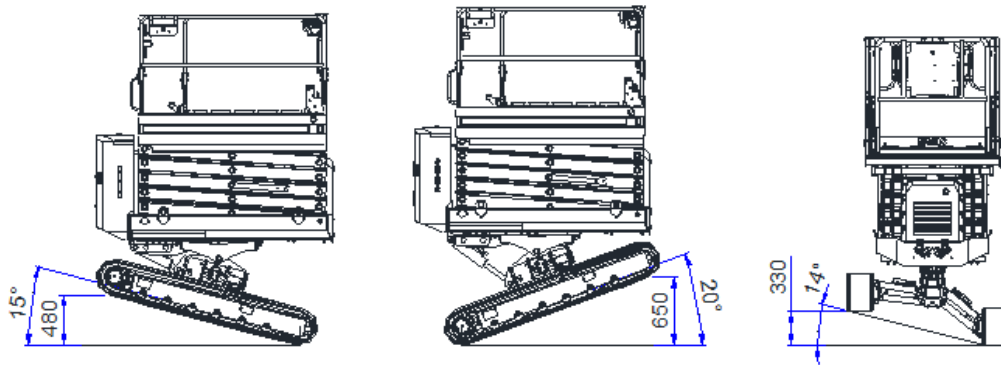

#### 4.2.5.1 Levelling in the transport configuration (with the upward movement of the work platform)

With the work platform completely lowered, it is possible to activate the automatic levelling by keeping selected the work platform upward control.

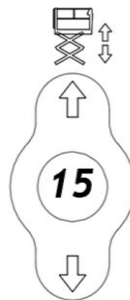

The system will bring the frame back to an inclination of less than 0.5° compared to the horizontal.

Once levelled, if the position of the selector is maintained, the upward movement of the work platform will be activated.

#### 4.2.5.2 Levelling in the transport configuration (operating the manual controls)

The MANUAL lateral and longitudinal levelling of the platform is possible only within the TRANSPORT HEIGHT (platform floor <2mt). It must be performed by carefully checking the inclination on the **spirit level** situated on the work platform, and by acting on the selectors 12, 13 and 14 on the console:

##### LH lateral levelling

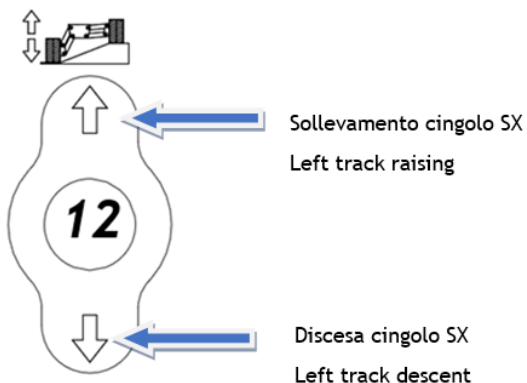

##### RH lateral levelling

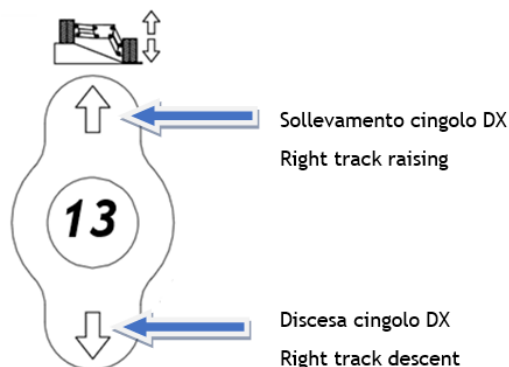

##### Longitudinal levelling

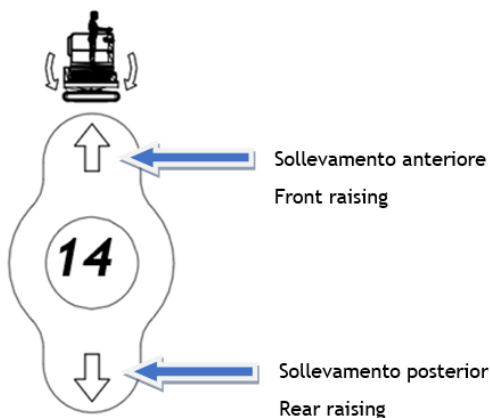

By activating any movement, the platform will stop automatically once it reaches the horizontal.

If the inclination of the platform remains within  $\pm 0.5^\circ$  both laterally and longitudinally, it is possible to lift the work platform.

Warning: manual levelling is less accurate than automatic levelling

#### 4.2.5.3 Dynamic Levelling during travel

Note: dynamic levelling can be activated only with the platform completely lowered.

Thanks to this system, the platform, while it is moving, will always remain levelled and once the operating area has been reached, the machine will already be in the condition to be lifted.

To activate this mode, it is necessary to turn selector 9 of the push-button panel to the HARE position and selector 8 to the "DRIVE MODALITY" or ED-S position.

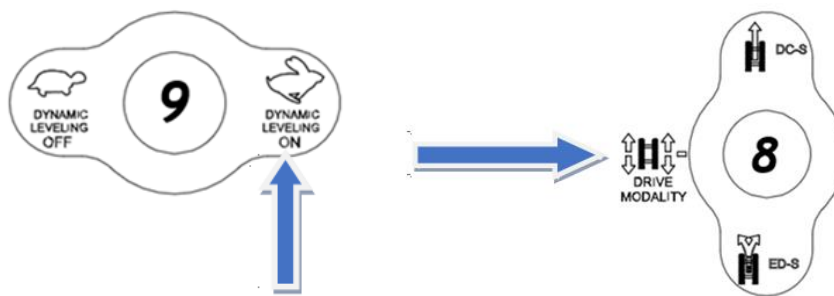

Warning: If selector 8 is positioned on DC-S, the function is not active.

#### 4.2.5.4 Proactive Levelling

Note: the Proactive Levelling is active only up to the maximum travel height allowed, which on this model is 4.5 mt platform floor (6.5 mt work).

This system allows to correct the levelling of the machine when it is at a height, if after travelling on not perfectly flat ground, the platform is no longer aligned with the ground itself.

Since the machine can also be levelled with the platform not in the transport position, another safety ring, both electric and hydraulic, has been added.

The levelling speeds are significantly reduced compared to those with the machine in the transport position.

This is wanted both to make the manoeuvre comfortable for the operators and to minimise the effects due to inertia.

This additional system is not required by standard UNI EN 280:2015

because it would be enough to have the normal frame inclination control made in performance level D as required in section 5.3.2.3 of the same standard.

This additional safety system is described in paragraph 3.4.2 "Redundant frame inclination and height control device"

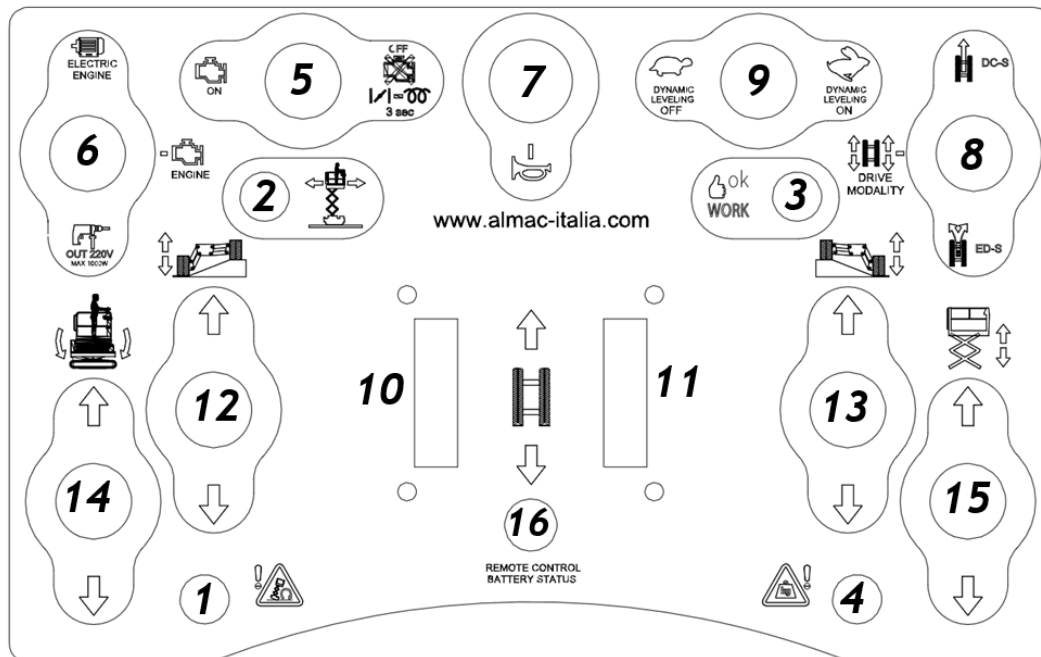

#### Preliminary notes:

- The system is active only when the platform floor is higher than 2mt
- The system is active only within 3° of inclination
- The system is active only if the work platform is below the maximum travel height of 4.5 mt platform floor (scissor frame angle with respect to frame 23°)
- If indicator light 1 is off, it means that the inclination is less than 0.5°
- If indicator light 1 is flashing, it means that the inclination is greater than 0.5° and less than 3°
- If indicator light 1 is on, it means that the inclination is greater than 3° or that the inclination is greater than 0.5° and the work platform is higher than the maximum travel height.

Warning: the Proactive levelling is active only if light 1 is flashing or off.

#### Operating principle:

During travel at a height if an inclination of 0.5° is exceeded, light 1 will start to flash; if 1° is exceeded, travel will stop.



- It is necessary to release the joysticks
- When the joysticks are reactivated, the platform will be levelled again. The levelling can be performed also by commanding the upward movement of the work platform.

Warning: If the levelling is performed by means of the joysticks, once the levelling has been completed, the machine will start to travel automatically in the selected direction!

When the machine is stopped if the platform is inclined by an angle between  $0.5^\circ$  and  $1^\circ$ , the system will level the platform:

- By operating the work platform up control

In the case of an exceptional event (ground subsidence, falling from a step, etc.) and the inclination of the frame is greater than  $3^\circ$ , all movements will be blocked, both by the main system and by the additional safety system.

- Light 1 will turn on
- It is possible to control the "work platform descent" only until the platform has been completely lowered



If the platform is higher than the transport height and the inclination of the machine compared to the ground is greater than the value allowed, the travel and lifting controls will be automatically inhibited

The table below lists the maximum permitted configurations previously described.

*Configuration summary table*

Frame inclination	Height of work platform	Travel	Levelling	Platform up
Any	Lower than the transport height	Allowed at maximum speed	Allowed Manual Dynamic levelling Automatic levelling	Allowed after levelling
$>0.5^\circ < 1^\circ$	Higher than the transport height but lower than the maximum travel height	Allowed but only at reduced speed	Proactive levelling allowed	Allowed after levelling
$>1^\circ < 3^\circ$	Higher than the transport height but lower than the maximum travel height	Not allowed	Proactive levelling allowed	Allowed after levelling
$>3^\circ$	Higher than the transport height but lower than the maximum travel height	Not allowed	Not allowed	Not allowed
$<0.5^\circ$	Higher than the maximum travel height	Not allowed	Not allowed	Allowed
$>0.5^\circ$	Higher than the maximum travel height	Not allowed	Not allowed	Not allowed

The inclination indicator light (see figure on the side), which indicates the platform inclination status, **through its ON or OFF conditions.**

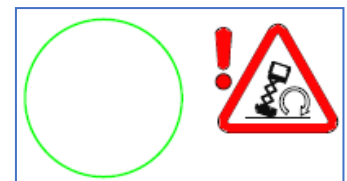

#### 4.2.6 Lifting/descent of the work platform

The work platform can be lifted by means of the dedicated selector on the control push-button panel. The lifting and descent speed are controlled by the electronic control unit (ECU).

The platform descent can also be performed with the combustion engine off but the electrical panel ON.

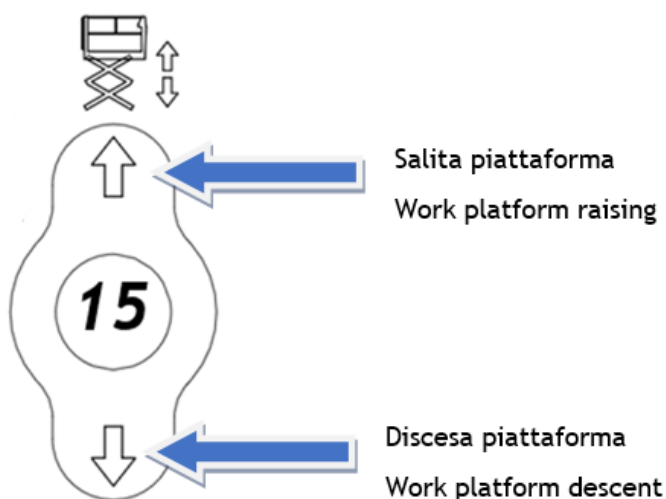

During the downward movement, the ANTI-CRUSHING function is activated, to prevent accidents to the operators on the ground near the machine.

#### 4.2.7 Manual warning buzzer

Use the button on the push-button to operate the platform buzzer. It must be used whenever persons working or moving around the platform area must be warned that platform movements are in progress.

Warning: The continuous use of this device reduces the battery charge.



### 4.3 Messages and alarms on the hour counter



The hour counter, placed next to the ladder, allows to display the machine status. This display also shows any errors and/or alarms that may occur.

If there are no alarms present, the display will show the hours of work with the electrical engine and with the internal combustion engine:



d = hours of operation with diesel engine



E = hours of operation with electrical engine

At the top, the starter battery charge will be displayed.

If there are alarms present, the display will show only the alarm codes.



If there are no alarms at the moment but there were alarms previously (alarms caused by malfunctions that appear intermittently), the service symbol will appear on the display:



The control unit can store up to 16 alarms which are shown by pressing the right button of the hour counter.

These alarms are not cancelled when the machine is turned off.



The table below shows the list of alarm/error codes.

CODE	DESCRIPTION
FUEL	Low fuel level (only Kubota engine) (Warning: This alarm is not stored)
90	Starter battery voltage lower than 9V
91	Starter battery voltage higher than 16V
92	EPROM memory internal error
93	CAN network communication error
40	Frame angle sensor redundancy error
30	Scissor angle sensor redundancy error
70	Pressure transducer redundancy error
41	No signal from the frame angle sensor 1
31	No signal from the scissor angle sensor 1
71	No signal from the pressure transducer 1
42	No signal from the frame angle sensor 2
32	No signal from the scissor angle sensor 2
72	No signal from the pressure transducer 2
10	No signal from the console
50	Right connecting rod angle sensor redundancy error
80	Left connecting rod angle sensor redundancy error
51	No signal from the right connecting rod angle sensor 1
81	No signal from the right connecting rod angle sensor 2
52	No signal from the left connecting rod angle sensor 1
82	No signal from the left connecting rod angle sensor 2
110	Low engine oil pressure (only Kubota engine)
111	Water temperature too high (only Kubota engine)
115	Platform upward movement detected without selecting the command
131	Alarm relay KM11 bonded
132	Alarm relay KM12 bonded
133	Alarm relay KM13 bonded
134	Alarm, the platform lowered limit switch signal is not consistent with the value of the scissor angle sensor

## 4.4 Stopping the machine

### 4.4.1 Normal stop

During normal platform use, releasing the TRANSLATION joysticks (10 and 11) stops the movement. Each track installed has a braking system that prevents the machine from moving unless hydraulic pressure is exercised to disengage it. Releasing the platform UP or DOWN (15) lever, under normal working conditions, stops the relative movement.

Disabling and restoring the platform have to occur as follows:

- Shut-down the platform according to the indications provided
- Cover the mobile push-button panel with its guard (1)
- Leave the work platform using the relative ladder
- Place the key selector (2) provided on the ground controls in the central position and then remove the key
- Disconnect the battery using the dedicated command and remove the key (3)

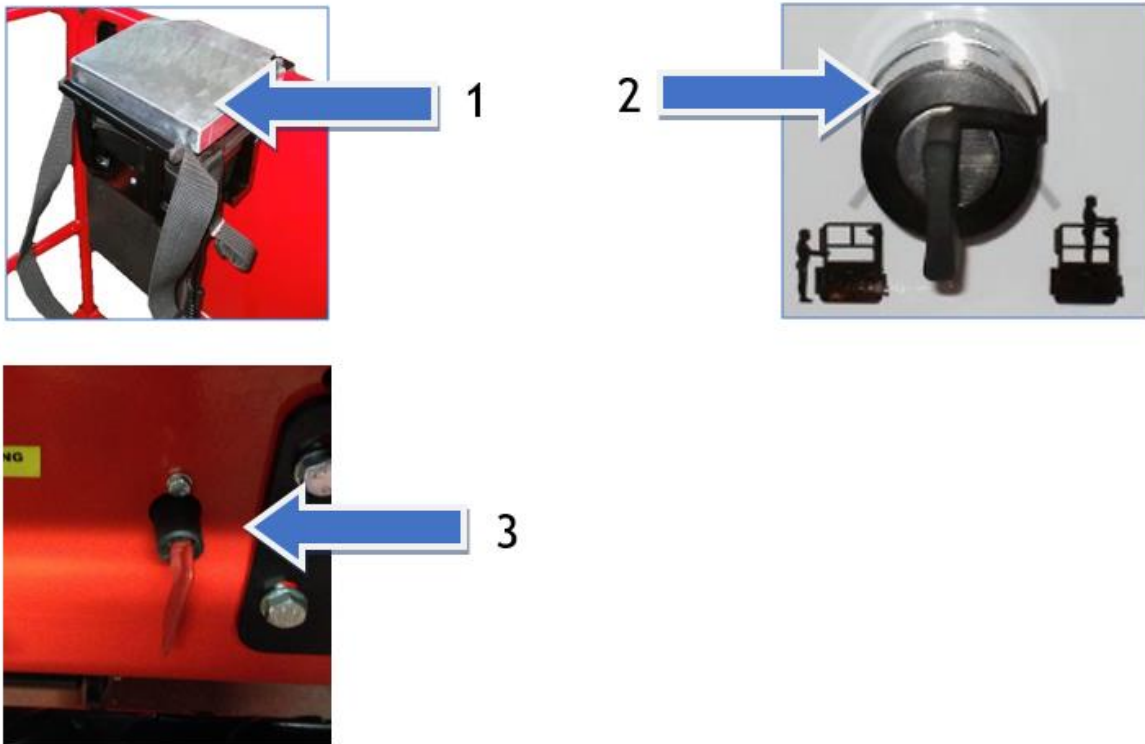

#### 4.4.2 Emergency stop

In abnormal circumstances, or situations in which all machine movements must be stopped, the operator can IMMEDIATELY STOP all the machine functions by pressing the MUSHROOM-SHAPED button on the push-button, or the emergency button place on the GROUND CONTROLS (see figures below).





## 5 Emergency procedures

### 5.1 Emergency manual descent

Following a failure in the electrical system or hydraulic circuit, the platform DESCENT manoeuvre can be performed from any height by means of the emergency control at ground level.

In this case, the operator on the ground (remember that at least one operator must be present at ground level to ensure the platform is used in safe conditions) must pull the hydraulic valve control installed on the lifting cylinder.

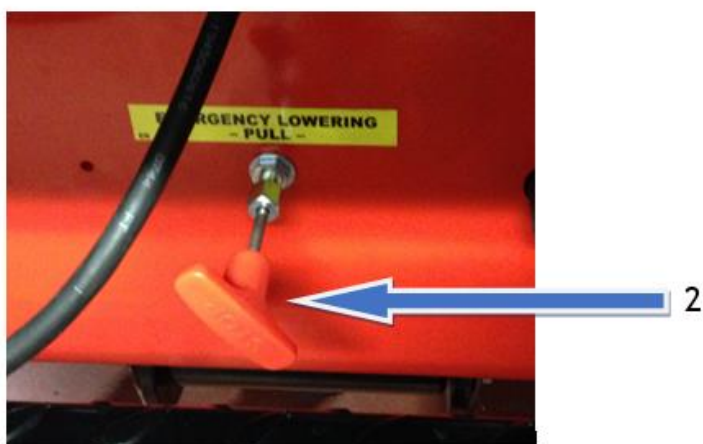
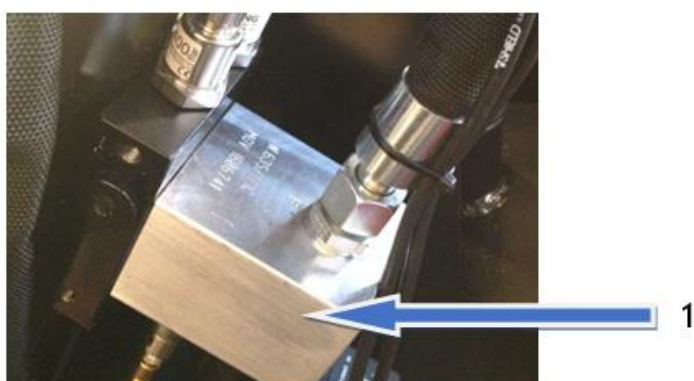

**Warning:** This mechanism must only be used in an emergency, i.e. electrical or hydraulic failure.

**Warning:** After using this control, push the knob towards the frame slightly and make sure that the spring has brought the mechanism back to its original position

### 5.2 Transporting the machine in an emergency

To move or transport the platform using external equipment, refer to paragraph 2.5

### 5.3 Emergency movements from hydraulic block

Warning: this operation must be performed only by qualified technicians trained by Almac Srl

If the control unit is not working but it is possible to turn on the internal combustion engine or the electrical engine, then it will be possible to perform then movements of the machine directly from the hydraulic block.

To perform the movements, it is necessary to release (by turning it counter-clockwise) safety valve 3 and tighten (by turning it clockwise) valves 1 and 2 (equipped with a lead seal).

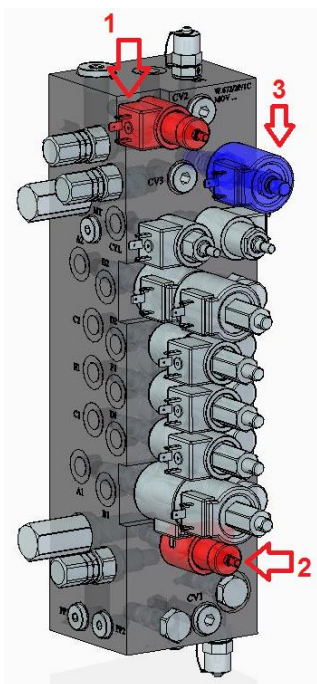

**WARNING: If valve 3 is not reset in the fully activated position by pressing and turning it clockwise (you will hear a click) and valves 1-2 are fully unscrewed (replace the lead seal), the safety of the machine is compromised and the platform may overturn.**

**WARNING: Since the operations are performed near the tracks, there is a risk of crushing**

### 5.4 Use hand pump in case of emergency

The Hand Pump is installed on the machine for the use in emergency situation only.

The purpose of the Hand Pump is to raise the platform should access inside the scissor stack be required if the engine or operating systems are not operational.

The use of the handpump for any other purpose is strictly forbidden.

- **POSITION**

- The hand pump rod is positioned inside the basket;

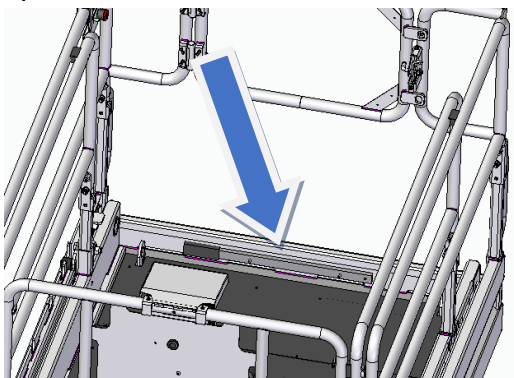

- The hand pump is positioned below one step of the access ladder.



- **INSTRUCTION FOR USE**

- 1- Release the rod from the basket by unscrewing the two butterfly nuts;

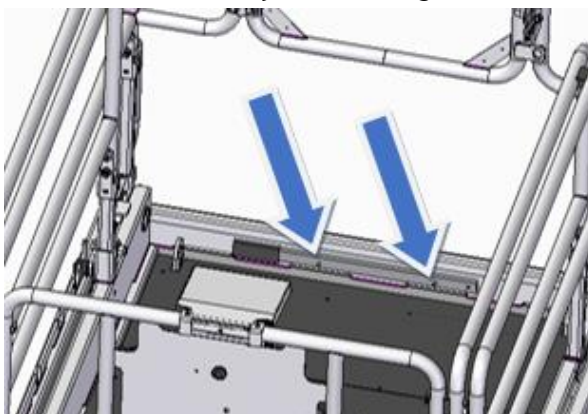

- 2- Remove the left crankcase from the access ladder;



- 3- Screw completely the slider of the BP2 valve;

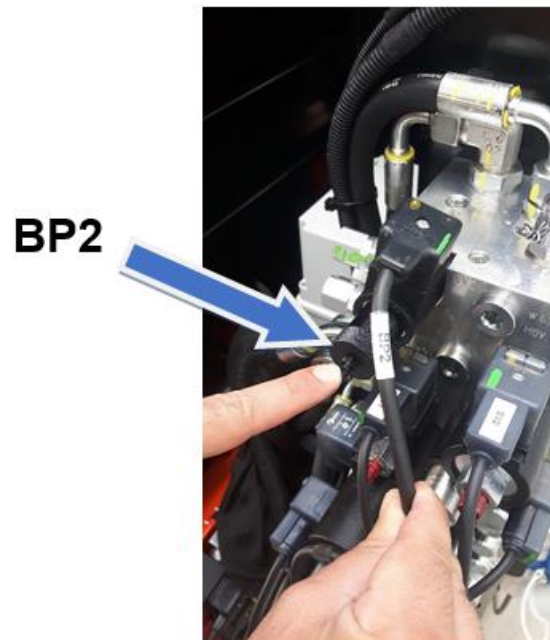

- 4- Insert the rod into the hand pump housing;

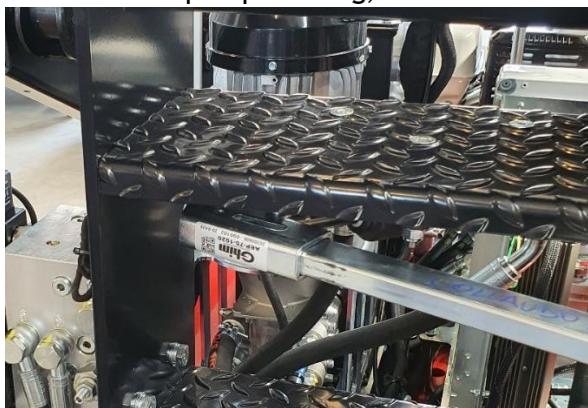

- 5- Simultaneously press the sliders of the valves SV1, SP2 and at the same time move the pump lever horizontally until the desired basket height is reached.

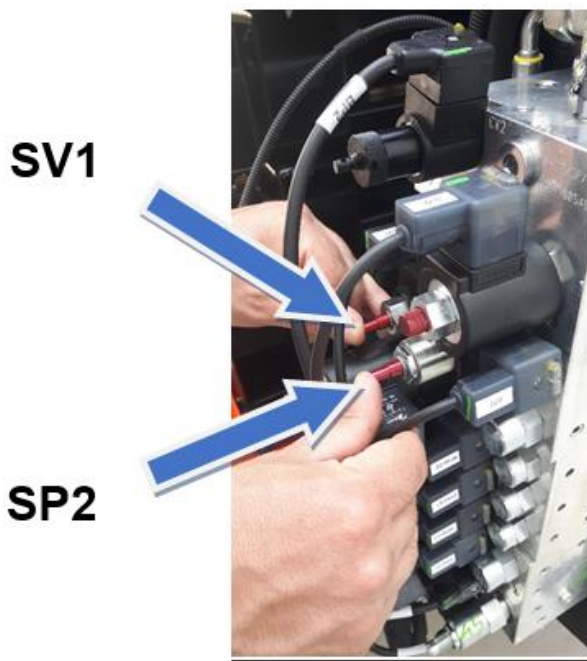

- 6- At conclusion of emergency operations, the operator must release the screw on valve BP2. This valve must be released for normal operations. Reinstall the hydraulic manifold protective cover before resuming operation.

## 6 Maintenance

### 6.1 General maintenance

The main maintenance interventions and the frequencies with which they must be carried out are given in the chart below.

#### 6.1.1 Ordinary maintenance schedule table

The checks and maintenance operations must be performed as indicated in the table below

ORDINARY MAINTENANCE SCHEDULE TABLE		A	C	D	E	F	G	H
			25	50	100	250	500	
Visual and functional checks as specified		X						X
Discharge filter cartridge replacement							X	
Suction filters replacement							X	
Check and, if necessary, grease the runners and nylon wheels		X	X					X
Check the hydraulic oil level		X						X
Change the hydraulic oil							X	
Track reduction gear oil level inspection						X		X
Replace oil in the track reduction gear							X	
Check the oil level in the engine		X						X
Change the engine oil * (*after the first 50 hours)			*X		X			
Replace engine oil filter.*					X			
Clean the engine air filter.*			X					X
Replace engine air filter.*						X		
Track inspection and tensioning		X						X
Check the condition of the tracks		X						X
Check the runners for wear					X			
Check the tightening of nuts and bolts (general checks)				X				
Check using a torque wrench the tightening of screws and bolts for fixing of the tracked chassis to the machine frame, the screws M16 class8.8 tightening torque 193 Nm (after the first 50 hours)					X			
Check the correct positioning of the Seeger rings of the scissors and their washers		X						X
Structural inspection (visual)		X				X		X
Structural inspection (through checking of metal parts and welds)						X		X
Check the overload monitoring device						X		
Manual emergency devices		X						X
Check the combustion engine battery		X						X
Check the correct operation of the 230V outlet differential						X		X
Check the Proactive levelling angle sensor						X		
Check the Proactive levelling redundancy valves						X		
Check and replace the fuses						X		X
Check the maximum pressure valve							X	
Check the main system angle sensors		X						X
Check the correct operation of the Sentinel							X	
A. Daily or every 10 hours	D. every two months or every 100 hours	G. after long periods of inactivity (90 days)						
B. Weekly or every 25 hours	E. quarterly or every 250 hours							
C. monthly or every 50 hours	F. annually or every 500 hours	* Refer to the engine use and maintenance manual						



**Warning:** All maintenance operations must be performed as indicated in *Chapter 2 Safety information*. In particular, maintenance must only be carried out after the emergency push-button has been pressed, the engine turned off and using individual protective equipment and the extendible structure locking system.

**Warning:** Disconnect the machine from all power sources

**Warning:** It is mandatory to perform all MEWP movements required for inspections/maintenance using the ground controls and without operators on the work platform. When checking machine operation from the work platform, the required movements must be performed as near to the ground as possible.

**Note:** Use of spurious spare parts, or parts that have not been approved by the manufacturer voids the warranty and relieves ALMAC S.r.l. from all liability.

**Note:** Modifications or variations to the MEWP are forbidden unless authorized by the manufacturer.

**Note:** All maintenance work that is not described in this manual must be authorized by the manufacturer and must be performed by authorised technicians.



**Warning:** Do not use the machine if one of its mechanical or hydraulic elements or a control or safety device is faulty! Immediately notify an Almac Srl customer assistance centre

### 6.1.2 Checks before each use

Prior to commissioning and before each use the machine must undergo the visual and functional checks given below.

The instructions given below must be followed.

VISUAL CHECK	CHECK OPERATION
--------------	-----------------

<ul style="list-style-type: none"> <li>• Visually check under and around the machine to make sure that there are no oil or fuel leaks.</li> <li>• Make sure that there is no hydraulic oil leaking from the hoses and from the other components (cylinders, distributors, fittings, etc.).</li> <li>• Check that there are no cut or worn electrical cables and that the connectors are correctly secured.</li> <li>• Check the fuel level before starting so as to prevent interruptions while working.</li> <li>• Check the engine oil level.</li> <li>• Check the hydraulic oil level.</li> <li>• Make sure that none of the screws, bolts or ferrules are loose or missing.</li> <li>• Make sure that all the "Seeger" safety rings are present and correctly in place with there washers.</li> <li>• Make sure that all the pins are in place and correctly secured.</li> <li>• Make sure the tracks are not cut or abnormally worn</li> <li>• Always check to make sure that track tension is correct</li> <li>• Check, and if necessary grease, the scissor runners, both those in contact with the platform and those in contact with the lower frame.</li> <li>• Check that the manual, the plates and the stickers are on the machine.</li> <li>• Check that the steel structure is not deformed.</li> <li>• Make sure there are no cracks in the welds, damage or abnormal wear</li> <li>• Make sure that the 12V internal combustion engine ignition battery is fully charged; a simple way to check is turning on the internal combustion engine, which must turn on easily.</li> <li>• Make sure that the gate leading to the platform closes and locks itself automatically once released.</li> <li>• Do not run the engine in closed areas like garages or the like. The engine exhaust gas contains carbon monoxide, a poisonous gas that can quickly saturate a closed space and cause</li> </ul>	<ul style="list-style-type: none"> <li>• With the platform in the transport configuration, place the machine with the frame tilted with respect to the horizontal by a value greater than 0.5° on the lateral. Operate the platform lifting control, make sure that the system automatically brings the frame to the horizontal position</li> <li>• With the platform in the transport configuration, place the machine with the frame tilted with respect to the horizontal by a value greater than 0.5° on the longitudinal. Operate the platform lifting control, make sure that the system automatically brings the frame to the horizontal position</li> <li>• With the platform in the transport configuration, place the machine with the frame tilted with respect to the horizontal at the maximum angle both on the longitudinal and on the lateral. Operate the platform lifting control, make sure that the system automatically brings the frame to the horizontal position</li> <li>• Lift the platform without a load to the maximum height and then lower it a few times; make sure that the machine works correctly</li> <li>• Check the operation of the anti-shearing device; this test is performed by lifting the platform to a height that involves an angle of the scissor frames greater than 12° with respect to the horizontal and make sure that the descent movement stops automatically at a scissor angle between 7° and 9° (the vertical distance between the ends of the scissors must be greater than 50mm). Further movements downwards are possible only after a 3s delay at reduced speed.</li> <li>• Check the operation of the travel function with the platform lifted; this test is performed by lifting the platform to a height that involves an angle of the scissor frames of 23° with respect to the horizontal (maximum height of transit area 4.5mt) and make sure that it is possible to travel with the machine only at reduced speed (light indicator 2 flashing ). Also make sure that at greater heights the light indicator (2) turns off and that it is not allowed to move.</li> <li>• Check that with the platform lifted higher than the transport height but lower than the maximum travel height (light 2 on) and moving</li> </ul>
---	--



<p>difficulties or even death.</p>	<p>on non-level terrain, the machine stops automatically when the inclination of the frame with respect to the horizontal exceeds 1°. Release the travel control; when this control is operated again or when the lifting control is operated, the system must bring the frame back to the horizontal position automatically. After the levelling, the machine will perform the selected movement.</p> <ul style="list-style-type: none"> <li>• Lift the platform to a height greater than the transport height, check that the manual levelling functions are not allowed.</li> <li>• Operate the emergency button on the remote control (or radio control); make sure that the engine turns off (both the internal combustion engine and the electrical engine) and that no functions are allowed. Release the mushroom-shaped button after this test.</li> <li>• Operate the ground movement emergency button; make sure that the engine turns off (both the internal combustion engine and the electrical engine) and that no functions are allowed. Release the mushroom-shaped button after this test.</li> <li>• Operate the warning buzzer and make sure it works.</li> <li>• Check the operation of the buzzer when the travel or work platform descent functions are used.</li> <li>• Make sure, with the machine travelling and the platform in the transport position (with travel selector on DM) that, when the Joysticks are released, the machine stops immediately.</li> <li>• Make sure that the manual emergency descent device works properly.</li> <li>• Make sure that the platform extension can move freely and that the pedal blocks it safely</li> <li>• Make sure that the folding railings are correctly positioned and secured</li> </ul>
------------------------------------	--

## 6.2 Maintenance: Details

The following points deal with the most significant specific cases

### 6.2.1 Checking and tightening screws, bolts, plug ring nuts

The operation of the following components must be checked. If necessary, the parts must be tightened with the appropriate tools as indicated in the charts on the following pages.

Clamping forces and tightening torque for bolts with a normal stroke metric thread (use the **Ma'** torque)

Resistance class in accordance with DIN/ISO 898			8.8		
Yielding point Rp 0,2 N/mm <sup>2</sup>			640 for <= M16 / 660 for >=M16		
Metric thread ISO	Cross-section of the powered zone	Cross section of the thread	Clamping force	For hydraulic and electrical torque wrench	<b>Ma'</b> = 0.9 MD* for the wrench
DIN 13	AS mm <sup>2</sup>	A3 mm <sup>2</sup>	FM [kN]	MA [Nm]	MA' [Nm]
M12	84.3	76.2	38.5	87	<b>78</b>
M14	115	105	72	140	<b>126</b>
M16	157	144	91	215	<b>193</b>
M18	193	175	117	300	<b>270</b>
M20	245	225	146	430	<b>387</b>
M22	303	282	168	580	<b>522</b>
M24	353	324	221	740	<b>666</b>
M27	459	427	270	1100	<b>990</b>
M33	561	519	335	1500	<b>1350</b>
M36	694	647	395	Bolt determined by measuring the yielding	
M39	817	759	475		
M42	976	913	542		

### 6.2.2 Visual and structural inspection

Visually check the following points according to the schedule indicated in the general chart. Immediately inform a maintenance technician if faults are discovered.

- Integrity of the railings of the work platform

- Condition of ladder
- Condition of lifting structure (scissors)
- Condition of the frame
- Status of the bi-levelling structure and of the tracked chassis
- In particular check if there is any rust in the structure
- Status of the rubber tracks
- Oil leaks
- Pins and their stop devices

### 6.2.3 Damage to tubes and cables

Visually check at the frequencies indicated in the general chart to make sure that the articulation point of the hydraulic hoses and electric cables are not misshapen or damaged. Examples of such faults are shown on the photos below.



*Damaged hydraulic hose pipe*

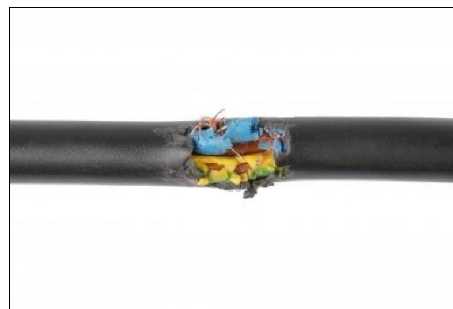

*Damaged electric cable*

### 6.2.4 Greasing the runners

Grease these parts at the frequency indicated in the general chart and EACH TIME that the following operations are performed:

- Washing the machine
- After a long period of inactivity
- After use in particularly harsh conditions, e.g. damp or dusty places, marine environments, etc.

The surfaces to be greased are those in contact with the runners, both in the frame and under the work platform (see figures below):



Remove all dirt from the parts before greasing.

Use grease type **PAKELO BEARING EP 2** or equivalent.

Warning: The correct cleaning and greasing of these surfaces is essential to correctly measure the load on the work platform. If these operations are not performed correctly, the load may be measured incorrectly with potential risks to the operators.

### 6.2.5 Greasing the nylon wheels of the platform extension

Grease these parts with the frequency indicated in the general chart and as specified for the runners.

The surfaces to be greased are those in contact with the wheels, both in the fixed part of the platform and in the extension (see figures below):



Remove all dirt from the parts before greasing.  
Use the same grease specified for the runners.

#### **6.2.6 Checking the hydraulic tank oil level and topping up if necessary**

The hydraulic oil level is checked by means of a level indicator located directly on the tank.

The correct oil level must be checked with the machine in the configuration indicated in the following pictures.

Machine with wide tracks (chassis completely lowered)

Platform supported by the dedicated safety supports



In this configuration, the oil level must be as shown in the figure below.

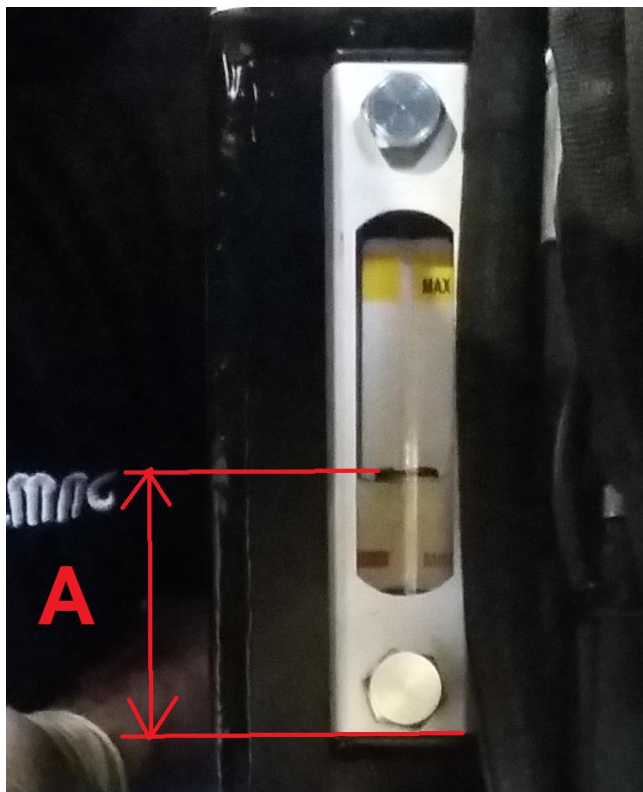

A = 60mm

### 6.2.7 Hydraulic reservoir oil change

The hydraulic oil in the tank must be changed with the frequency indicated in the general chart.

1. Collect the used oil in a suitable vessel and dispose of it in the proper way.
2. Empty then tank by means using a manual (2) or electric (3) pump making use of the filler cap placed on top of the tank (4). Warning: the pumps are not included.

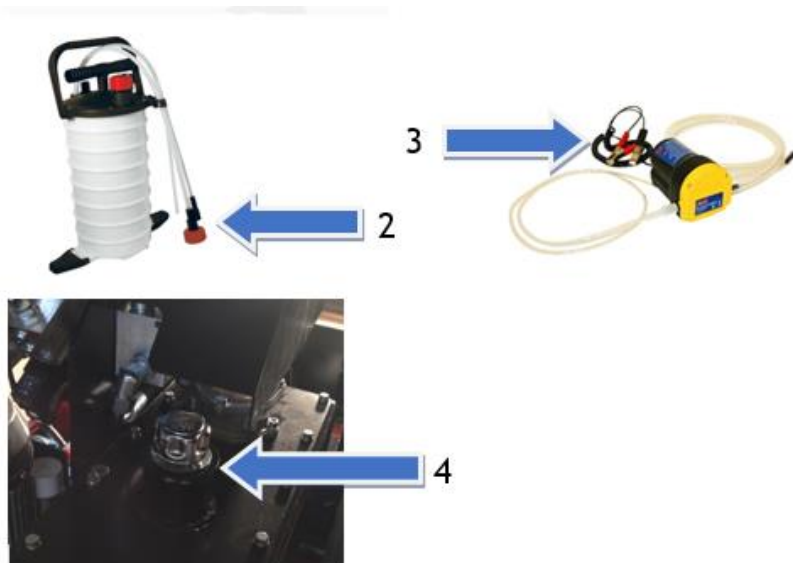

Warning: DO NOT DISPERSE USED OIL INTO THE ENVIRONMENT. USE SPECIAL COLLECTION CENTRES!



### 6.2.8 Checking the operation of the maximum pressure valves

With the frequency indicated in the general chart, check the operation of the maximum pressure valves of the distributor.

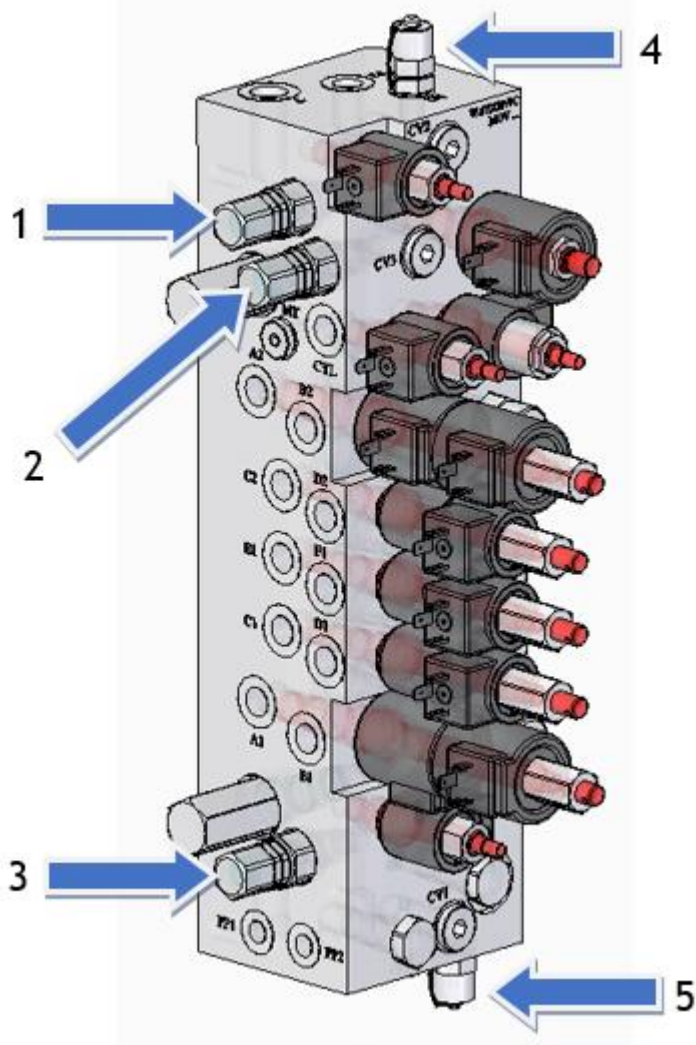

To test them, connect two pressure gauges with a full scale of 250 bar to the pressure outlets supplied (4 and 5).

#### Checking the general maximum pressure valves of the system (1 and 3)

The pressure gauges relating to these valves are those connected to the outlets 4 and 5.

- Start the internal combustion engine.
- Perform the levelling movements until the limit switch has been reached and keep them in this position for a few seconds. This activates the maximum pressure valve of the circuit.
- Read the pressure on the gauge, which should be  $200 \text{ bar} \pm 5 \text{ bar}$

#### Checking the maximum pressure valves relating to lifting (2)

The pressure gauge relating to this valve is the one connected to outlet 4.

- d) Start the internal combustion engine.
- e) Press the platform "up" button (15) until it reaches the limit and hold it down. This activates the pressure relief valve of the lift circuit.
- f) Read the pressure on the gauge, which should be 160 bar  $\pm$  5 bar

Warning: to allow the lifting cylinder to reach its mechanical limit switch, it is necessary to disable the electronic limit switch. Only specialised technicians, authorised by Almac Srl, must perform this operation.

The valves are calibrated during the testing phase performed by ALMAC Srl and should not require further adjustment unless:

- the hydraulic circuit is replaced
- the actual pressure relief valve is replaced

In these cases, the valve must be calibrated by SPECIALIZED PERSONNEL according to the monitoring procedure described above. Using the appropriate tools, unscrew the lock nut (1) and tighten or loosen the adjuster screw (2) until the indicated pressure level has been reached. Once the adjustments have terminated, tighten the lock nut (1) to hold the screw in position.

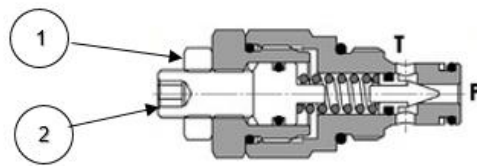

*Diagram of the pressure relief valve*



Warning: the calibration operation must only be performed by SPECIALIZED personnel. It must not be done by a generic operator.

## 6.2.9 Battery

### 6.2.9.1 General warnings

The battery is an essential component for machine operation. It is important to ensure that it remains in a good condition over time since this will lengthen its working life, limit any problems that may arise and reduce the running costs of the machine.

Comply with the following instructions:

- Charge the battery in ventilated areas.
- Keep open flames well away from the battery since explosive gases may form.
- Do not make temporary electrical connection that fail to comply with the regulations in force.
- Do not place tools or any other metal object on the battery.
- Clean any encrustations from the battery terminals and always tighten them correctly.
- Always keep the battery clean, dry and free from oxidation.
- If the battery is replaced, always comply with the instructions supplied with it.

### 6.2.9.2 Maintenance

The batteries chosen by ALMAC S.r.l. and installed on all models are of the “**maintenance-free**” type. These batteries feature construction technology that reduces water consumption to a considerable extent and maintains the electrolyte for the entire life cycle of the batteries themselves.

### 6.2.9.3 Recharging

Recharge the battery only in ventilated areas.



Warning: when charging, gas develops that in certain conditions can create EXPLOSIVE ATMOSPHERES.

Always recharge batteries in well ventilated places that conform to standards EN 60079-10 (IEC 31-30), where there is no risk of fire outbreaks and where suitable extinguishers are ready to hand.

### 6.2.9.3.1 Charging method No. 1 with 12V battery charger

Recharge the battery only in ventilated areas.

With the main switch QS1 (battery disconnect switch) turned to the ON position, connect the positive pole of the battery charger to the 150A fuse or to the dedicated connector placed under the ladder; connect the negative pole of the battery charger to the frame.

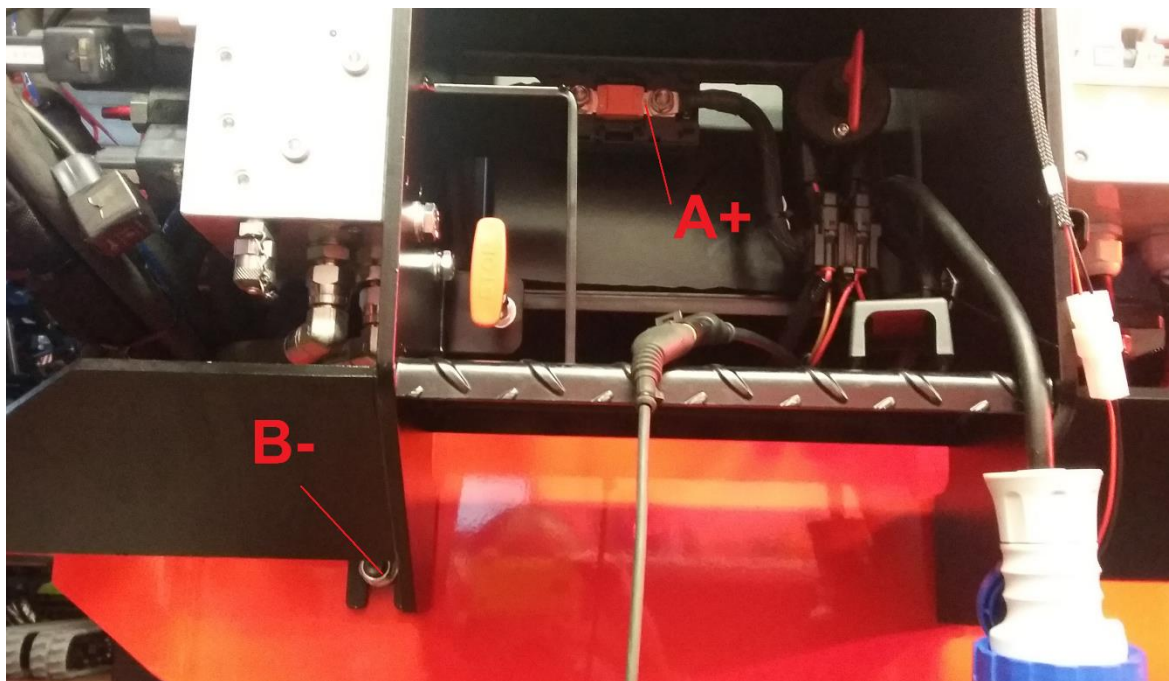

Disconnect the battery charger when the relative indicator shows that the battery is charged.

Connect the battery charger to an electric power supply that conforms to the following specifications:

- Voltage: 230 v  $\pm$  10%
- Frequency: 50 Hz
- Grounding line working and equipped with a differential circuit breaker
- Use an extension power cord with an appropriate section depending on its length

### 6.2.9.3.2 Charging method No. 2 using the 230V plug in the ladder

If the machine is equipped with a 230V electric motor, it is possible to recharge the battery simply by connecting the plug in the ladder to the external power source. The 230V AC/12V DC converter will recharge the battery



2 = Converter 230V AC/ 12V DC

Connect the plug to an electric power supply that conforms to the following specifications:

- Voltage: 230 v  $\pm$  10%
- Frequency: 50 Hz
- Grounding line working and equipped with a differential circuit breaker
- Use an extension power cord with an appropriate section depending on its length

### 6.2.9.3.3 Charging method No. 3 using the internal combustion engine

With the internal combustion engine running, the battery recharges automatically.

Moreover, if the 220V current source is present, it is possible to keep the engine at an accelerated rate simply by placing selector (6) on OUT 220V

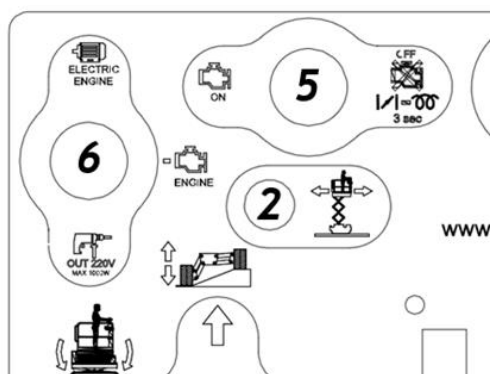

The battery will be charged at 18-20 Amps

### 6.2.10 Hydraulic filter replacement

Replace the discharge filters of the hydraulic circuit at the frequencies indicated in the general chart.

The hydraulic oil tank features:

- 2 or 4 suction filters inside the tank (1)
- 1 discharge filter in the top part of the tank (2).

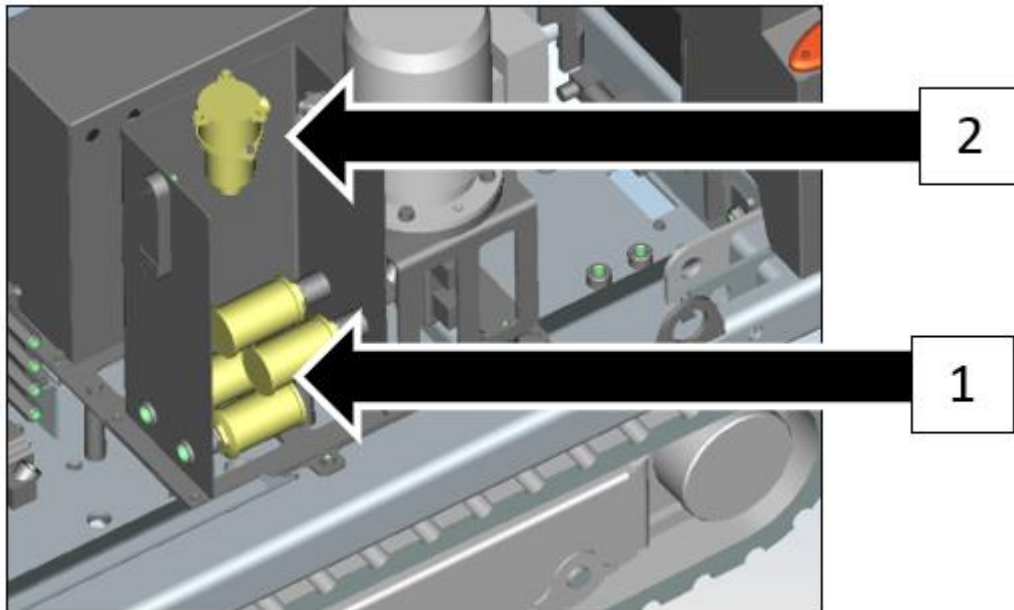

#### 6.2.10.1 Suction filters replacement

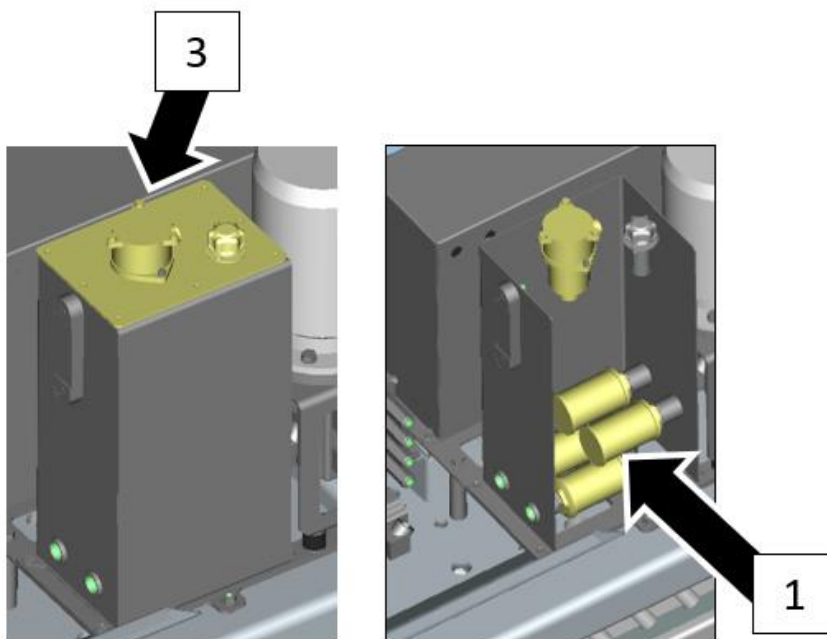

To replace the discharge filters located inside the hydraulic tank, proceed as follows:

- 1) Arrange the machine with the extending structure lifted and block it with the special mechanical locks for maintenance. **Now turn it off and deactivate the electric panel**
- 2) Empty the hydraulic oil reservoir
- 3) Unscrew the blocking screws (3) on the hydraulic tank lid and remove it from its housing
- 4) Remove the cartridge of the filters (1)
- 5) Remove the filter (1) and fit a new one in its place.
- 6) Work through the instructions above in reverse order to restore the machine to its normal operating conditions
- 7) Seal the lid with sealing paste
- 8) Fill the hydraulic oil reservoir with oil and check the level.

### 6.2.10.2 Replacement of return filter

To replace the discharge filter (2) located above the hydraulic tank, proceed as follows:

- 1) Arrange the machine with the extending structure lifted and block it with the special mechanical locks for maintenance. **Now turn it off and deactivate the electric panel**
- 2) Unscrew the blocking screws (4) on the filter and remove it from its housing
- 3) Unscrew the filter cartridge (5). Take care of the seals and/or O-rings.
- 4) Remove the cartridge (6) and fit a new one in its place.
- 5) Work through the instructions above in reverse order to restore the machine to its normal operating conditions.

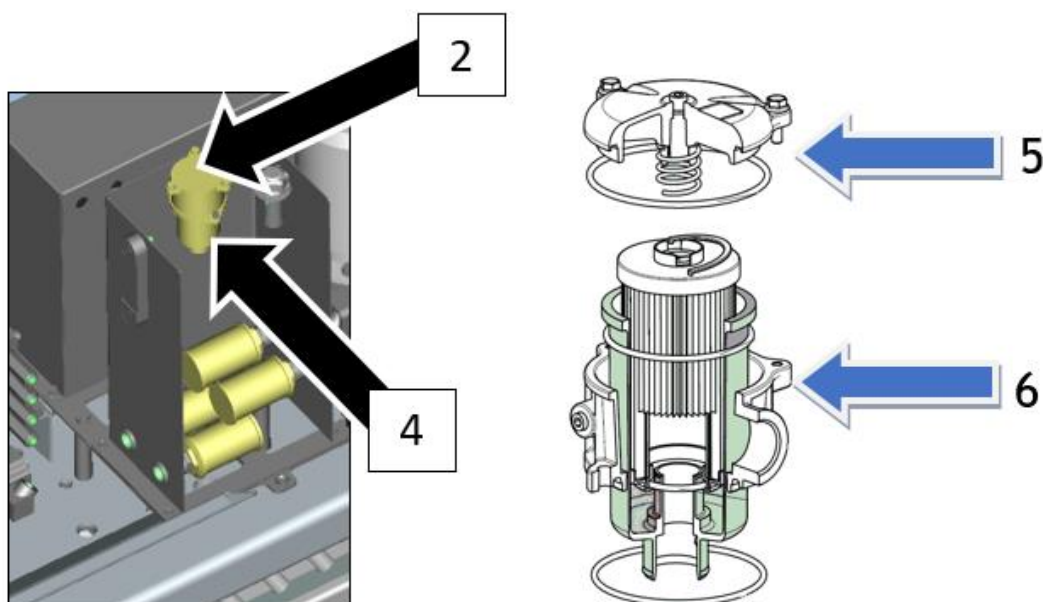

Warning: during operations some oil could spill. Remove spilt oil with a cloth or place a vessel underneath so that the oil drains into it.

**ONLY USE GENUINE SPARE PARTS** when replacing the filters. Contact the **ALMAC** technical assistance service.

Do not reuse used oil. Do not dispose of it in the environment. Used oil must be disposed of as required by the laws in force.



### 6.2.11 Checking the operation of the frame angle sensor

With the frequency indicated in the general chart, check the frame angle sensor.

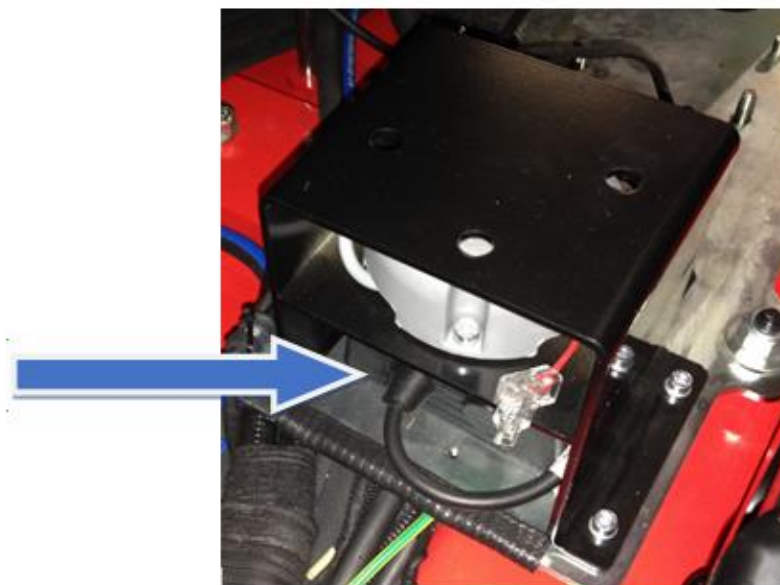

- With the platform in the transport configuration, place the machine with the frame tilted with respect to the horizontal by a value greater than  $0.5^\circ$  on the lateral. Operate the platform lifting control, make sure that the system automatically brings the frame to the horizontal position
- With the platform in the transport configuration, place the machine with the frame tilted with respect to the horizontal by a value greater than  $0.5^\circ$  on the longitudinal. Operate the platform lifting control, make sure that the system automatically brings the frame to the horizontal position
- With the platform in the transport configuration, place the machine with the frame tilted with respect to the horizontal at the maximum angle both on the longitudinal and on the lateral. Operate the platform lifting control, make sure that the system automatically brings the frame to the horizontal position

If the operations described above take place in the indicated sequence, it means that the angle sensor is working properly.

**Warning:** if the conditions indicated above are not met, do not use the machine and contact a qualified technician trained by Almac Srl

### 6.2.12 Checking the operation of the scissor angle sensor

With the frequency indicated in the general chart, check the scissor angle sensor.



- Lift the platform to a height greater than the transport height, check that the manual levelling functions are not allowed.
- Check the operation of the anti-shearing device; this test is performed by lifting the platform to a height that involves an angle of the scissor frames greater than  $12^\circ$  with respect to the horizontal and make sure that the descent movement stops automatically at a scissor angle between  $7^\circ$  and  $9^\circ$  (the vertical distance between the ends of the scissors must be greater than 50mm). Further movements downwards are possible only after a 3s delay at reduced speed.
- Check the operation of the travel function with the platform lifted; this test is performed by lifting the platform to a height that involves an angle of the scissor frames of  $23^\circ$  with respect to the horizontal (maximum height of transit area 4.5mt) and make sure that it is possible to travel with the machine only at reduced speed (light indicator 2 flashing ). Also make sure that at greater heights the light indicator (2) turns off and that it is not allowed to move.

If the operations described above take place in the indicated sequence, it means that the angle sensor is working properly.

Warning: if the conditions indicated above are not met, do not use the machine and contact a qualified technician trained by Almac Srl

### 6.2.13 Checking the operation of the Proactive levelling redundant angle sensor

With the frequency indicated in the general chart, check the redundant angle sensor of the Proactive Levelling system.

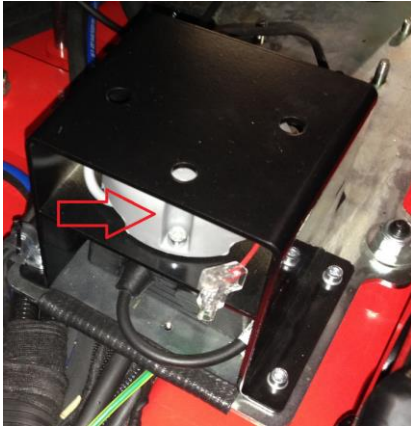

- With the platform in the transport configuration, place the machine with the frame tilted with respect to the horizontal by a value slightly greater than 3° on the lateral. Keep pressed, by inserting a wedge, the limit switch shown in the figure below



- Try to perform the manual levelling operations; make sure that they are all disabled.
- Repeat the operation with the frame tilted with respect to the horizontal with a value slightly greater than 3° on the longitudinal
- Try to perform the manual levelling operations; make sure that they are all disabled.

Warning: if the movements are not disabled, do not use the machine and contact a qualified technician trained by Almac Srl

### 6.2.14 Checking the differential circuit breaker

With the frequency indicated in the general chart, check the differential circuit breaker

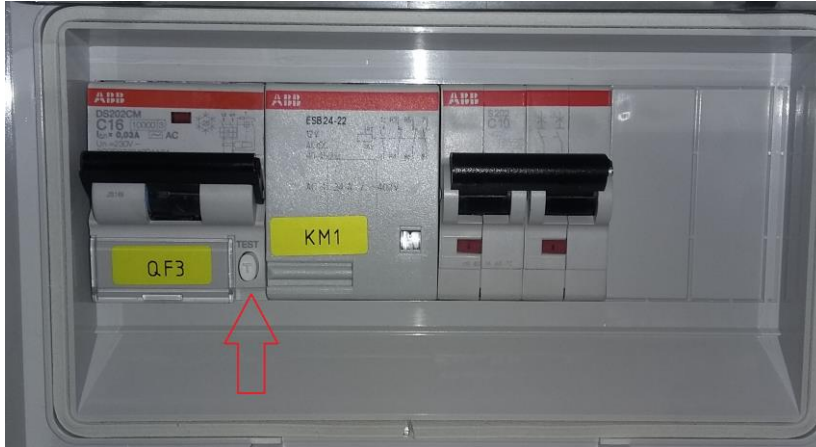

Connect the plug in the ladder to an electric power supply that conforms to the following specifications:

- Voltage: 230 v  $\pm$  10%
- Frequency: 50 Hz
- Grounding line working and equipped with a differential circuit breaker
- Use an extension power cord with an appropriate section depending on its length

Press the button indicated in the figure and make sure that the differential switch is triggered.



WARNING: IN THIS CONFIGURATION, THE OUTLET ON THE WORK PLATFORM IS POWERED; THEREFORE HIGH VOLTAGE IS PRESENT. THIS OPERATION MUST BE PERFORMED ONLY BY QUALIFIED TECHNICIANS.

### 6.2.15 Electrical insulation monitoring device operation test

With the frequency indicated in the general chart, check the operation of the device that monitors the electrical insulation of the 220V power supply of the inverter (only if present).

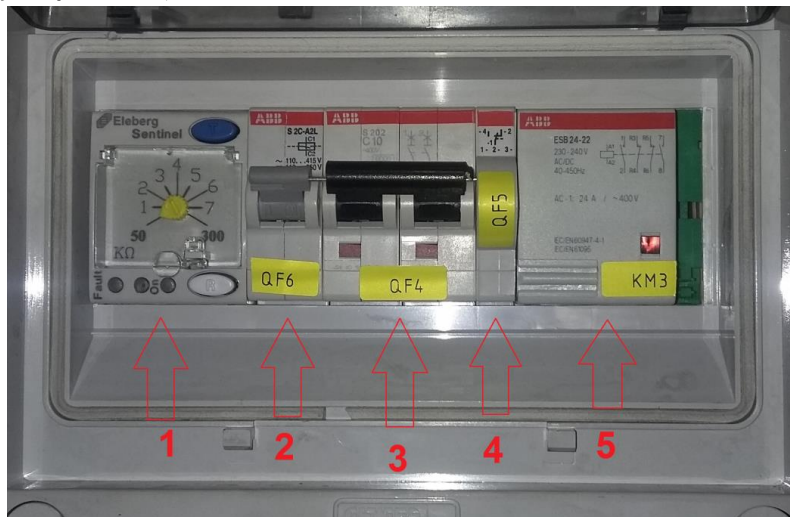

The test must be performed with the internal combustion engine on, selector 6 on the console must be in the "OUT 220 V" position. In fact, this enables 220 V voltage to be supplied to the outlet on the work platform.

At this point, it is necessary to simulate a dispersion by making a bridge with a cable between the outlet on the work platform and a grounding point of the machine.

This simulates an abnormal situation and automatic voltage release by the device. When the device is released, an warning buzzer located on the electrical panel will emit a steady sound, which will remain active until the operator reactivates the breaking device.



**WARNING: IN THIS CONFIGURATION, THE OUTLET ON THE WORK PLATFORM IS POWERED; THEREFORE HIGH VOLTAGE IS PRESENT. THIS OPERATION MUST BE PERFORMED ONLY BY QUALIFIED TECHNICIANS.**

### 6.2.16 Manual emergency device operation test

Test the operation of the manual EMERGENCY DESCENT device at the inspection frequency indicated in the general chart.

Near the access ladder, indicated with special stickers, there is a control lever which, when pulled, allows the platform to lower in any condition, i.e.:

- With the combustion engine off
- When the electrical system is faulty or off
- In the absence of battery voltage



**WARNING:** THIS MECHANISM MUST ONLY BE USED IN AN EMERGENCY, i.e. ELECTRICAL OR HYDRAULIC FAILURE.

### 6.2.17 Checking the operation of the “Proactive levelling” safety valves

With the frequency indicated in the general chart, check the additional levelling locking valves.

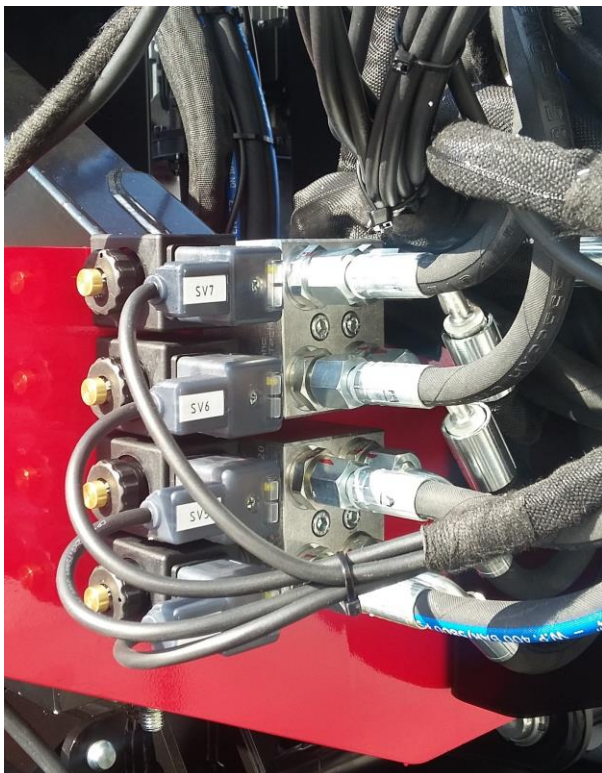

Remove the connectors from the solenoid valves and try to perform manual levelling operations with the machine in the transport position.

All the movements must be prevented and the maximum pressure relief valves of the hydraulic block will be activated.

Warning: At the end of the test, restore the connectors as before.

Warning: if the conditions indicated above are not met, do not use the machine and contact a qualified technician trained by Almac Srl

### 6.2.18 Checking the seal of the cylinder balancing valves

Warning: this operation must be performed only by qualified technicians trained by Almac Srl

With the frequency indicated in the general chart (as for the Proactive levelling safety valves), check the seal of the flanged valves on the cylinders.

To perform this check, it is necessary to:

- 1) Position the machine as indicated in the figure (chassis completely raised and platform extended)
- 2) Place 300Kg as shown in the figure

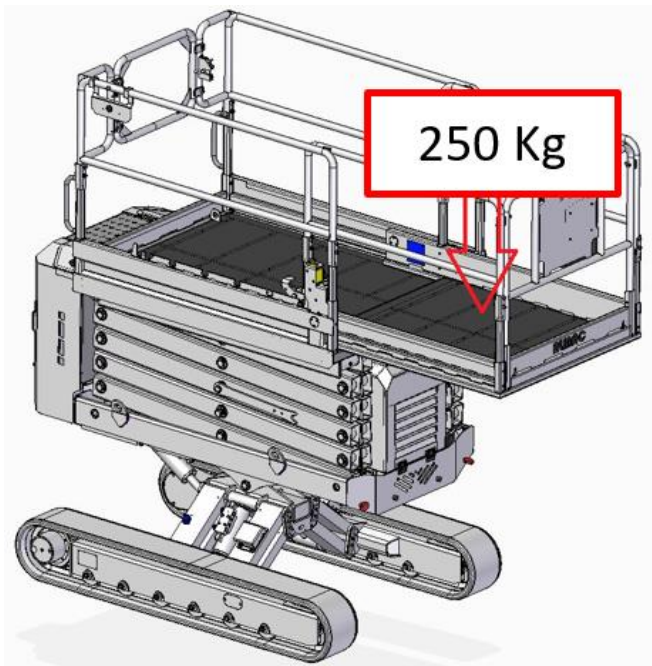

- 3) Perform the procedure with the remote controller (running time 90 minutes)
- 4) Make sure that the machine remains in the position where it was left and that there were no movements due to oil leaking from the valves (because of a malfunction or impurities trapped in the cursor).
- 5) If the test has a positive outcome, position the machine as indicated in the figure (chassis completely raised and platform retracted)
- 6) Place 300Kg as shown in the figure



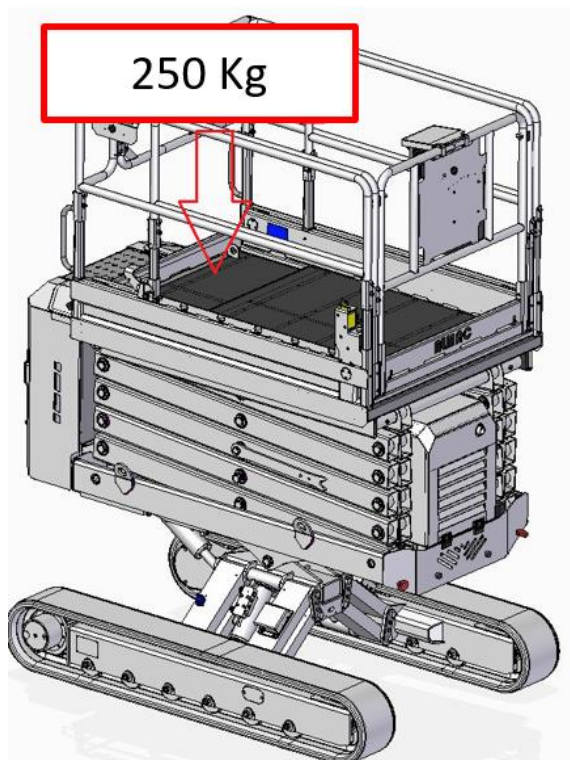

- 7) Perform the procedure with the remote controller (running time 90 minutes)
- 8) Make sure that the machine remains in the position where it was left and that there were no movements due to oil leaking from the valves (because of a malfunction or impurities trapped in the cursor).

Warning: if the test has a negative outcome, do not use the machine and contact a qualified technician trained by Almac Srl

### 6.2.19 Procedure with remote controller for checking the seal of the cylinder balancing valves

Warning: this operation must be performed only by qualified technicians trained by Almac Srl

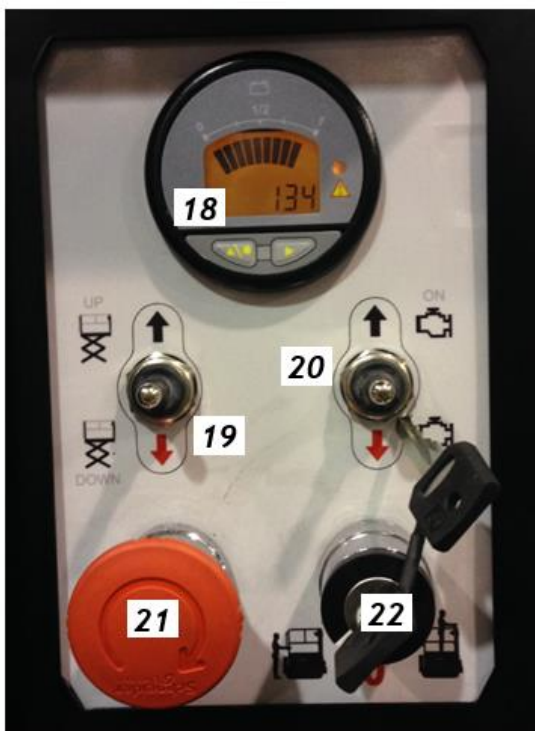
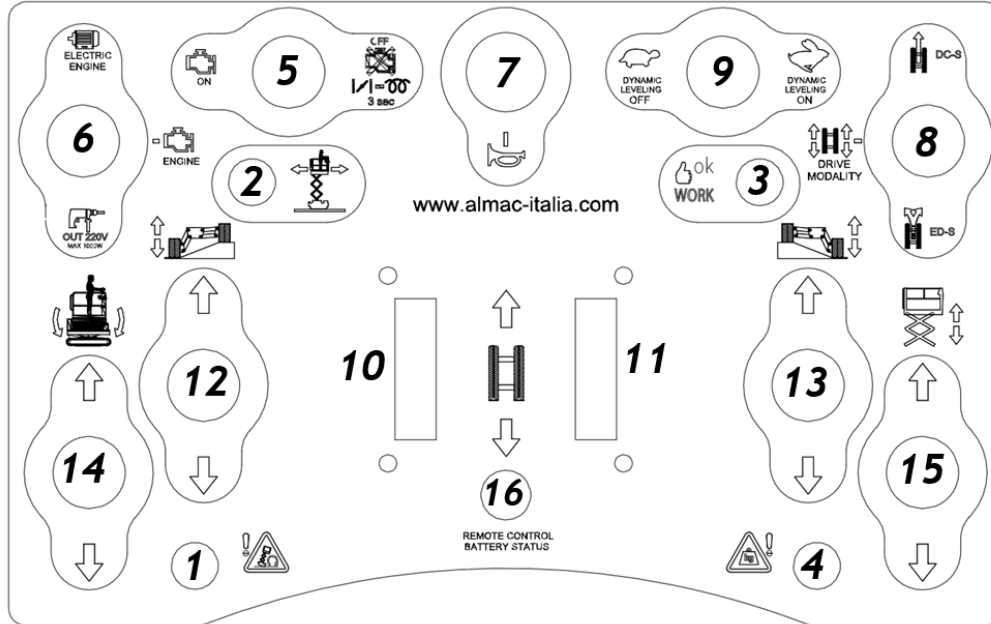

- 1) Push the emergency push button on controller;
- 2) Select commands on chassis (22);
- 3) Release the emergency push button on Console;
- 4) The lamps 1-2-3-4 come on, when only the red lamps 1-4 are steady press two times selector 14 forward and after two times selector 12 forward
- 5) The procedure that open the valves SV 4-5-6-7 begin, the valves are energized for 90 minutes, an a count down will be shown on the hour meter (from 90 to 0)
- 6) At the beginning of the procedure starts the endothermic engine by means the selector (20), or connect the plug with the external power supply if the unit is equipped with the electric motor.
- 7) At the end of the procedure a counter will be increased in the ECU memory

## 6.2.20 Maintenance of the engine

Below are general instructions for the correct maintenance of the engine.  
In any case, always consult the use and maintenance manual of the engine.

### SERVICE INTERVALS

Observe the following for service and maintenance.

The lubricating oil change intervals listed in the table below are for Classes CF, CE and CD lubricating oils of API classification with a low-sulfur fuel in use. If the CF-4 or CG-4 lubricating oil is used with a high-sulfur fuel, change the lubricating oil at shorter intervals than recommended in the table below depending on the operating condition.

Interval	Item	Ref. page		
Every 50 hours	Check of fuel pipes and clamp bands	12		@
See NOTE	Change of engine oil (depending on the oil pan)	13,14	☉	
Every 100 hours	Cleaning of air cleaner element	18,19	*1	@
	Cleaning of fuel filter	12		
	Check of battery electrolyte level	19,20		
	Check of fan belt tightness	21		
Every 200 hours	Check of radiator hoses and clamp bands	17		
	Replacement of oil filter cartridge (depending on the oil pan)	15	☉	
	Check of intake air line	-		@
Every 400 hours	Replacement of fuel filter element	12		@
Every 500 hours	Removal of sediment in fuel tank	-		
	Cleaning of water jacket (radiator interior)	-		
	Replacement of fan belt	21		
Every one or two months	Recharging of battery	19,20		
Every year or every six cleanings of air cleaner element	Replacement of air cleaner element	18,19	*2	@
Every 800 hours	Check of valve clearance	23		
Every 1500 hours	Check of fuel injection nozzle injection pressure	-	*3	@
Every 3000 hours	Check of turbo charger	-	*3	@
	Check of injection pump	-	*3	@
	Check of fuel injection timer	-	*3	@
Every two years	Replacement of battery	19,20		
	Replacement of radiator hoses and clamp bands	17		
	Replacement of fuel pipes and clamps	12	*3	@
	Change of radiator coolant (L.L.C.)	15		
	Replacement of intake air line	-	*4	@

## FUEL

Fuel is flammable and can be dangerous. You should handle fuel with care.



### CAUTION

To avoid personal injury:

- Do not mix gasoline or alcohol with diesel fuel. This mixture can cause an explosion.
- Be careful not to spill fuel during refueling. If fuel should spill, wipe it off at once, or it may cause a fire.
- Do not fail to stop the engine before refueling. Keep the engine away from the fire.
- Be sure to stop the engine while refueling or bleeding and when cleaning or changing fuel filter or fuel pipes. Do not smoke when working around the battery or when refueling.
- Check the above fuel systems at a well ventilated and wide place.
- When fuel and lubricant are spilled, refuel after letting the engine cool off.
- Always keep spilled fuel and lubricant away from engine.

### ■ Fuel level check and refueling

1. Check to see that the fuel level is above the lower limit of the fuel level gauge.
2. If the fuel is too low, add fuel to the upper limit. Do not overfill.

No.2-D is a distillate fuel oil of lower volatility for engines in industrial and heavy mobile service.

(SAE J313 JUN87)

Grade of Diesel Fuel Oil According to ASTM D975

Flash Point, °F (°C)	Water and Sediment, volume %	Carbon Residue on, 10 percent Residuum, %	Ash, weight %
Min	Max	Max	Max
125 (52)	0.05	0.35	0.01

Distillation Temperatures, °F(°C) 90% Point		Viscosity Kinematic cSt or mm <sup>2</sup> /s at 40°C		Viscosity Saybolt, SUS at 100°F	
Min	Max	Min	Max	Min	Max
540 (282)	640 (338)	1.9	4.1	32.6	40.1
Sulfur, weight %		Copper Strip Corrosion		Cetane Number	
Max		Max		Min	
0.40		No. 3		40	

The cetane number is required not less than 45.

### IMPORTANT :

- Be sure to use a strainer when filling the fuel tank, or dirt or sand in the fuel may cause trouble in the fuel injection pump.
- For fuel, always use diesel fuel. You are required not to use alternative fuel, because its quality is unknown or it may be inferior in quality, and kerosene, which is very low in cetane rating, adversely affects the engine. Diesel fuel differs in grades depending on the temperature.
- Be careful not to let the fuel tank become empty, or air can enter the fuel system, necessitating bleeding before next engine start.

### ■ Air bleeding the fuel system



### CAUTION

To avoid personal injury:

- Do not bleed a hot engine as this could cause fuel to spill onto a hot exhaust manifold creating a danger of fire.

Air bleeding of the fuel system is required if:

- after the fuel filter and pipes have been detached and refitted;
- after the fuel tank has become empty; or
- before the engine is to be used after long storage.

**[PROCEDURE]**

1. Fill the fuel tank to the fullest extent. Open the fuel filter cock.
2. Loosen air vent plug of the fuel filter a few turns.
3. Screw back the plug when bubbles do not come up any more.
4. Open the air vent plug on top of the fuel injection pump.
5. Retighten the plug when bubbles do not come up any more.

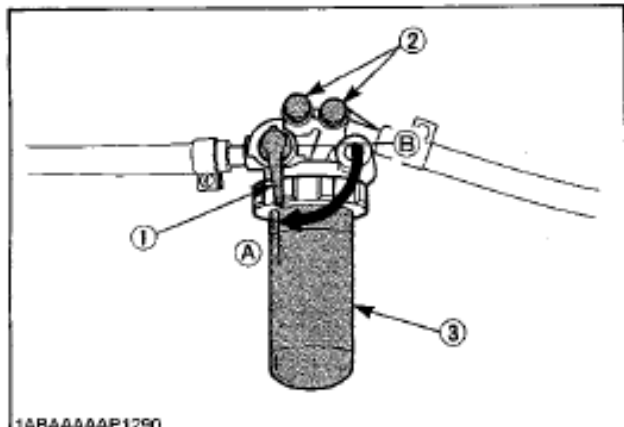

1ABAAAAAP1290

- (1) Fuel filter cock  
(2) Air vent plug  
(3) Fuel filter pot
- (A) "ON"  
(B) "OFF"

**■ Checking the fuel pipes****CAUTION**

To avoid personal injury;

- Check or replace the fuel pipes after stopping the engine. Broken fuel pipes can cause fires.

Check the fuel pipes every 50 hours of operation. When if;

1. If the clamp band is loose, apply oil to the screw of the band, and tighten the band securely.
2. If the fuel pipes made of rubber became worn out replace them and clamp bands every two years.
3. If the fuel pipes and clamp bands are found worn or damaged before two years'time, replace or repair them at once.
4. After replacement of the pipes and bands, air-bleed the fuel system.

**IMPORTANT :**

- When the fuel pipes are not installed, plug them at both ends with clean cloth or paper to prevent dirt from entering. Dirt in the pipes can cause fuel injection pump malfunction.

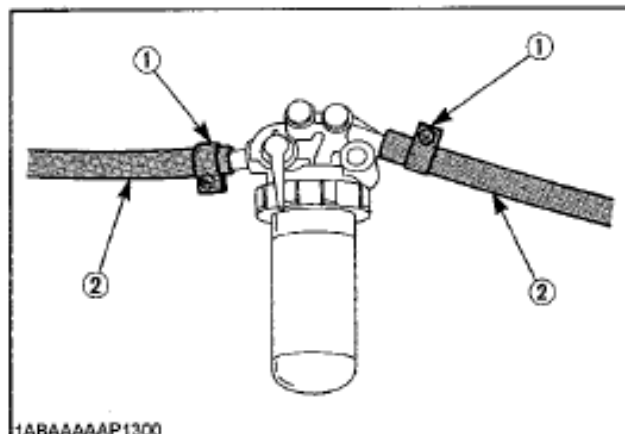

1ABAAAAAP1300

- (1) Clamp band  
(2) Fuel pipe

**■ Cleaning the fuel filter pot**

Every 100 hours of operation, clean the fuel filter in a clean place to prevent dust intrusion.

1. Close the fuel filter lever.

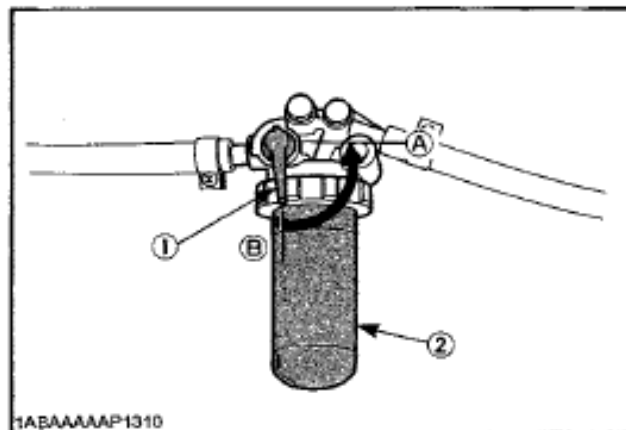

1ABAAAAAP1310

- (1) Fuel filter lever  
(2) Fuel filter pot
- (A) "OFF"  
(B) "ON"

2. Remove the top cap, and rinse the inside with diesel fuel.
3. Take out the element, and rinse it with diesel fuel.
4. After cleaning, reinstall the fuel filter, keeping out of dust and dirt.
5. Air-bleed the injection pump.

**IMPORTANT :**

- Entrance of dust and dirt can cause a malfunction of the fuel injection pump and the injection nozzle. Wash the fuel filter cup periodically.

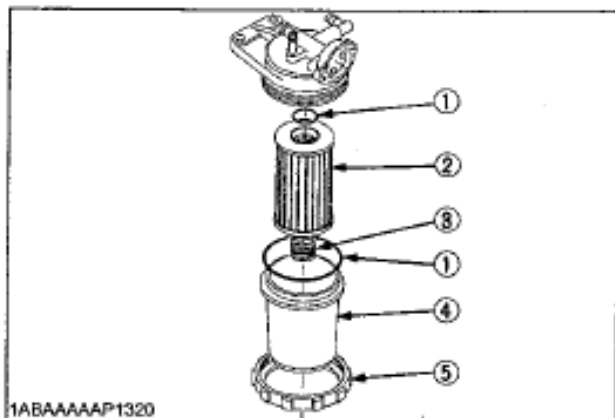

- (1) O ring
- (2) Filter element
- (3) Spring
- (4) Filter bowl
- (5) Screw ring

## ENGINE OIL



### CAUTION

To avoid personal injury:

- Be sure to stop the engine before checking and changing the engine oil and the oil filter cartridge.
- Do not touch muffler or exhaust pipes while they are hot; Severe burns could result. Always stop the engine and allow it to cool before conducting inspections, maintenance, or for a cleaning procedure.
- Contact with engine oil can damage your skin. Put on gloves when using engine oil. If you come in contact with engine oil, wash it off immediately.

### NOTE :

- Be sure to inspect the engine, locating it on a horizontal place. If placed on gradients, accurately, oil quantity may not be measured.
- Be sure to keep the oil level between upper and lower limits of the oil gauge. Too much oil may cause a drop in output or excessive blow-by gas. On the closed breather type engine in which mist is sucked through port, too much oil may cause oil hammer. While too little oil, may seize the engine's rotating and sliding parts. (The closed breather is an option.)

### ■ Checking level and adding engine oil

1. Check the engine oil level before starting or more than five minutes after stopping.
2. Detach the oil level gauge, wipe it clean and reinstall it.
3. Take the oil level gauge out again, and check the oil level.

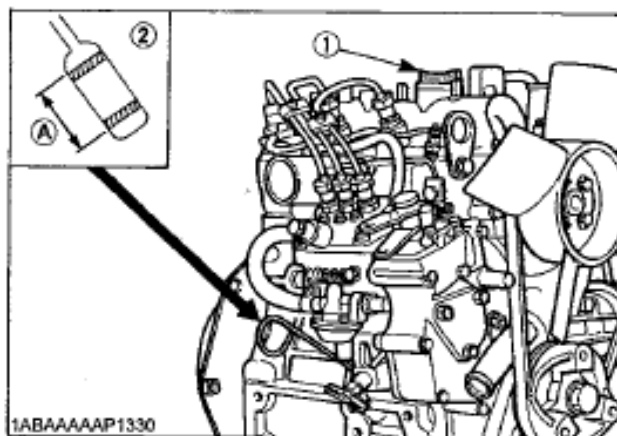

- (1) Oil filler plug
- (2) Oil level gauge

[Lower end of oil level gauge]

(A): Engine oil level within this range is proper.

4. If the oil level is too low, remove the oil filler plug, and add new oil to the prescribed level.
5. After adding oil, wait more than 5 minutes and check the oil level again. It takes same time for the oil to come down to the oil pan.

## Engine oil quantity

Models	Oil pan depth	
	*101 mm (3.98 in.)	121 mm (4.76 in.)
Z482-E	2.1 L (0.55 U.S.gal.)	2.5 L (0.66 U.S.gal.)
D662-E D722-E	3.2 L (0.84 U.S.gal.)	3.8 L (1.0 U.S.gal.)
D782-E	-	3.6 L (0.95 U.S.gal.)
Z602-E	101 mm (3.98 in.)	-
	2.5 L (0.66 U.S.gal.)	
D902-E	101 mm (3.98 in.)	-
	3.7 L (0.98 U.S.gal.)	

\*101mm(3.98in.) oil pan depth is optional.

Oil quantities shown are for standard oil pans.

**IMPORTANT :**

- Engine oil should be MIL-L-2104C or have properties of API classification CD grades or higher.  
Change the type of engine oil according to the ambient temperature.

above 25° C (77° F)	SAE30 or SAE10W-30 SAE10W-40
0° C to 25° C (32° F to 77° F)	SAE20 or SAE10W-30 SAE10W-40
below 0° C (32° F)	SAE10 or SAE10W-30 SAE10W-40

- When using oil different from the previous one, be sure to drain all the previous oil before supplying it into the crankcase.

**Changing engine oil****CAUTION**

To avoid personal injury:

- Be sure to stop the engine before draining engine oil.
- When draining engine oil, place some container underneath the engine and dispose it according to local regulations.
- Do not drain oil after running the engine. Allow engine to cool down sufficiently.

1. Change oil after the initial 50 hours of operation and every 100 hours thereafter.
2. Remove the drain plug at the bottom of the engine, and drain all the old oil. Drain oil easier and completely while the engine is hot.

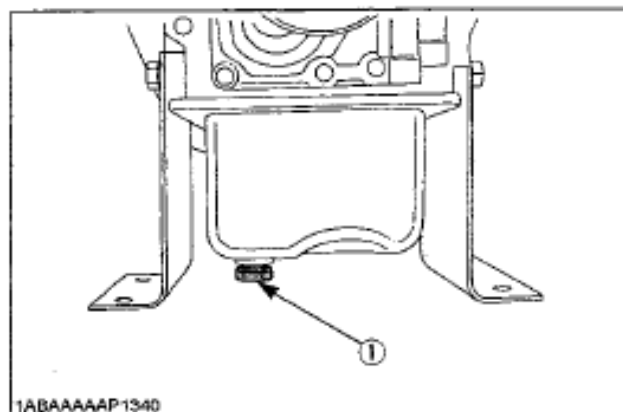

(1) Oil drain plug

3. Add new engine oil up to the upper limit of the oil level gauge.



## ■ Replacing the oil filter cartridge

### ⚠ CAUTION

To avoid personal injury:

- Be sure to stop the engine before changing the oil filter cartridge.
  - Allow engine to cool down sufficiently, oil can be hot and cause burns.
1. Replace the oil filter cartridge after the initial 50 hours of operation and every 200 hours thereafter.
  2. Detach the old oil filter cartridge with a filter wrench.
  3. Apply a film of oil to the gasket for the new cartridge.
  4. Screw in the cartridge by hand. When the gasket contacts the seal surface, tighten the cartridge enough by hand. Because, if you tight the cartridge with wrench, it will be tightened too much.

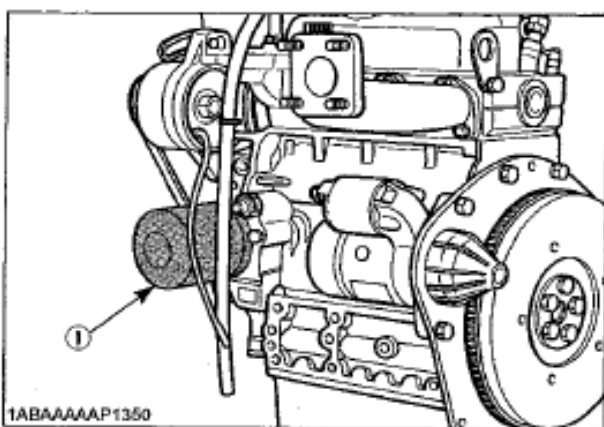

- (1) Oil filter cartridge  
Remove with a filter wrench  
(Tighten with your hand)

5. After the new cartridge has been replaced, the engine oil level normally decreases a little. Thus, run the engine for a while and check oil leaks through the seal before checking the engine oil level. Add oil if necessary.

#### NOTE :

- Wipe off any oil sticking to the machine completely.

## RADIATOR

Coolant will last for one day's work if filled all the way up before operation start. Make it a rule to check the coolant level before every operation.

### ⚠ WARNING

To avoid personal injury:

- Do not stop the engine suddenly, stop it after about 5 minutes of unloaded idling.
- Work only after letting the engine and radiator cool off completely (more than 30 minutes after it has been stopped).
- Do not remove the radiator cap while coolant is hot. When cool to the touch, rotate cap to the first stop to allow excess pressure to escape. Then remove cap completely. If overheats should occur, steam may gush out from the radiator or reserve tank; Severe burns could result.

## ■ Checking coolant level, adding coolant

1. Remove the radiator cap, and check to see that coolant reaches the supply port.

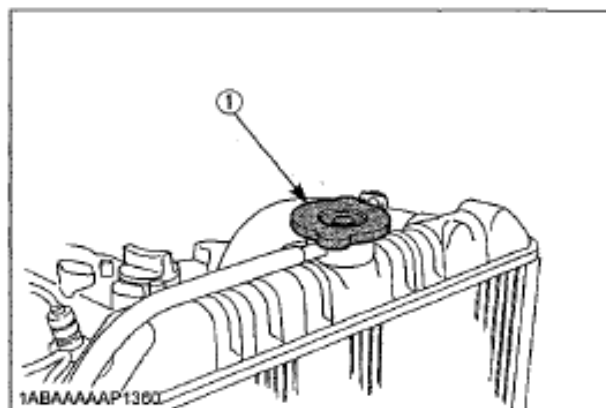

- (1) Radiator pressure cap

2. If the radiator provided with a reserve tank, check the coolant level of the reserve tank. When it is within between the "FULL" and "LOW" marks, the coolant will last for one day's work.

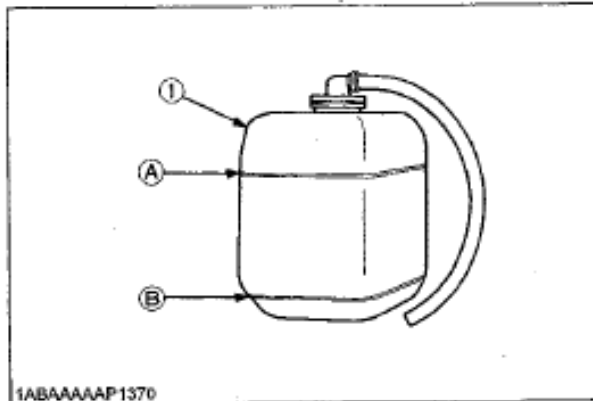

1ABAAAAAP1370

(1) Reserve tank

(A) "FULL"

(B) "LOW"

3. When the coolant level drops due to evaporation, add water only up to the full level.
4. Check to see that two drain cocks; one is at the crankcase side and the other is at the lower part of the radiator as figures below.

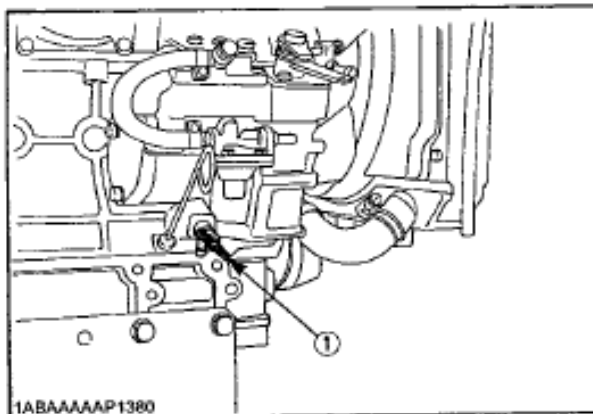

1ABAAAAAP1380

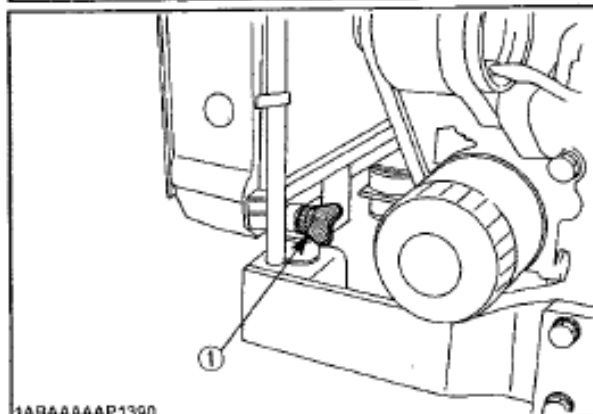

1ABAAAAAP1390

(1) Coolant drain cock

**IMPORTANT :**

- If the radiator cap has to be removed, follow the caution and securely retighten the cap.
- If coolant should be leak, consult your local KUBOTA dealer.
- Make sure that muddy or sea water does not enter the radiator.
- Use clean, fresh water and 50% anti-freeze to fill the recovery tank.
- Do not refill reserve tank with coolant over the "FULL" level mark.
- Be sure to close the radiator cap securely. If the cap is loose or improperly closed, coolant may leak out and decrease quickly.

### ■ Changing coolant

1. To drain coolant, always open both drain cocks and simultaneously open the radiator cap as well. With the radiator cap kept closed, a complete drain of water is impossible.
2. Remove the overflow pipe of the radiator pressure cap to drain the reserve tank.
3. Prescribed coolant volume (U.S.gallons)

Models	Quantity
Z482-E, Z602-E	2.8L (0.74 U.S.gal.)
D662-E, D722-E, D782-E, D902-E	3.1L (0.82 U.S.gal.)

#### NOTE :

- Coolant quantities shown are for standard radiators.
4. An improperly tightened radiator cap or a gap between the cap and the seat quickens loss of coolant.
  5. Coolant (Radiator cleaner and anti-freeze)

Season	Coolant
Summer	Pure water and radiator cleaner
Winter (when temperature drops below 0° C (32° F) or all season)	Pure water and anti-freeze (See "Anti-freeze" in Maintenance Section)

### ■ Checking radiator hoses and clamp



#### CAUTION

To avoid personal injury:

- Be sure to check radiator hoses and hose clamps periodically. If radiator hose is damaged or coolant leaks, overheats or severe burns could occur.

Check to see if radiator hoses are properly fixed every 200 hours of operation or six months, whichever comes first.

1. If hose clamps are loose or water leaks, tighten hose clamp securely.
  2. Replace hoses and tighten hose clamps securely, if radiator hoses are swollen, hardened or cracked.
- Replace hoses and hose clamps every 2 years or earlier if checked and found that hoses are swollen, hardened or cracked.

### ■ Precaution at overheating

Take the following actions in the event the coolant temperature be nearly or more than the boiling point, what is called "Overheating". Take these actions if the engine's alarm buzzer sounds or the alarm lamp lights up.

1. Stop the engine operation in a safe place and keep the engine unloaded idling.
2. Do not stop the engine suddenly, but stop it after about 5 minutes of unloaded idling.
3. If the engine stalls within about 5 minutes of running under no load, immediately leave and keep yourself away from the machine. Never open the hood and any other part.
4. Keep yourself and others well away from the engine for further 10 minutes or while the steam blown out.
5. Checking that there gets no danger such as burn, get rid of the causes of overheating according to the manual, see "Troubleshooting" section. And then, start again the engine.

### ■ Anti-freeze



#### CAUTION

To avoid personal injury:

- When using anti-freeze, put on some protection such as rubber gloves.
- If should drink anti-freeze, throw up at once and take medical attention.
- When anti-freeze comes in contact with the skin or clothing, wash it off immediately.
- Do not mix different types of anti-freeze.
- Keep fire and children away from anti-freeze.
- Be mindful of the environment and ecology. Before draining any fluids, find out the correct way of disposing by checking with local codes.
- Also, observe the relevant environmental protection regulations when disposing of oil, fuel, coolant, brake fluid, filters and batteries.

If it freezes, coolant can damage the cylinders and radiator. It is necessary, if the ambient temperature falls below 0° C (32° F), to remove coolant after operating or to add anti-freeze to it.

1. There are two types of anti-freeze available; use the permanent type (PT) for this engine.
2. Before adding anti-freeze for the first time, clean the radiator interior by pouring fresh water and draining it a few times.
3. The procedure for mixing of water and anti-freeze differs according to the make of the anti-freeze and the ambient temperature, basically it should be referred to SAE J1034 standard, more specifically also to SAE J814c.
4. Mix the anti-freeze with water, and then fill in to the radiator.

**IMPORTANT :**

- When the anti-freeze is mixed with water, the anti-freeze mixing ratio must be less than 50%.

Vol % Anti-freeze	Freezing Point		Boiling Point *	
	°C	°F	°C	°F
40	-24	-12	106	222
50	-37	-34	108	226

\*At  $1.013 \times 10^5$  Pa (760mmHg) pressure (atmospheric).  
A higher boiling point is obtained by using a radiator pressure cap which permits the development of pressure within the cooling system.

**NOTE :**

- The above data represent industry standards that necessitate a minimum glycol content in the concentrated anti-freeze.
- When the coolant level drops due to evaporation, add water only to keep the anti-freeze mixing ratio less than 50%. In case of leakage, add anti-freeze and water in the specified mixing ratio before fill in to the radiator.
- Anti-freeze absorbs moisture. Keep unused anti-freeze in a tightly sealed container.
- Do not use radiator cleaning agents when anti-freeze has been added to the coolant. (Anti-freeze contains an anti-corrosive agent, which will react with the radiator cleaning agent forming sludge which will affect the engine parts.)

**■ Radiator cement**

As the radiator is solidly constructed, there is little possibility of water leakage. Should this happen, however, radiator cement can easily fix it. If leakage is serious, contact your local KUBOTA dealer.

**AIR CLEANER**

As the element of the air cleaner employed on this engine is a dry type, never apply oil to it.

1. Open the evacuator valve once a week under ordinary conditions-or daily when used in a dusty place-to get rid of large particles of dust and dirt.
2. Wipe the inside air cleaner clean with cloth or the like if it is dirty or wet.
3. Avoid touching the element except when cleaning.
4. When dry dust adheres to the element, blow compressed air from the inside turning the element. Pressure of compressed air must be under 205kPa (2.1kgf/cm<sup>2</sup>, 30psi).
5. When carbon or oil adheres to the element, soak the element in detergent for 30 minutes, then wash it several times in water, rinse with clean water and dry it naturally.
6. After element is fully dried, inspect inside of the element with a light and check if it is damaged or not. (referring to the instructions on the label attached to the element.)
7. Replace the element every year or every six cleanings.

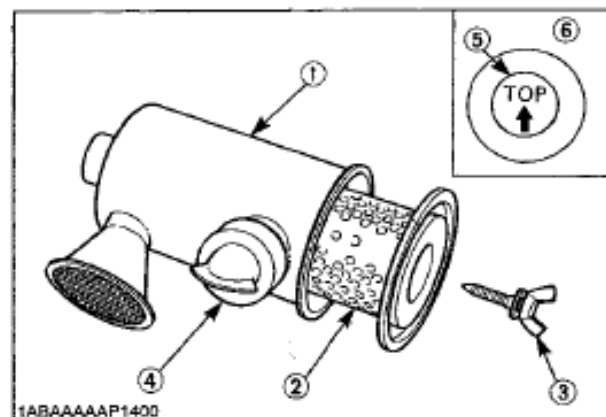

- 1ABAAAAAP1400
- (1) Air cleaner body
  - (2) Element
  - (3) Wing bolt
  - (4) Evacuator valve
  - (5) "TOP" mark
  - (6) Dust cup

**IMPORTANT :**

- Make sure the wing bolt for the element is tight enough. If it is loose, dust and dirt may be sucked, wearing down the cylinder liner and piston ring earlier and thereby resulting in poor power output.

### ■ For the air cleaner with a dust cup (optional)

Remove and clean out the dust cup before it becomes half full with dust; usually once a week, or even every day if the working surroundings are dusty.

Install the air cleaner dust cup with "TOP" indicated on the rear of the cup in the upside. (However, it may be installed in either direction when the cover is placed at the lower part.)

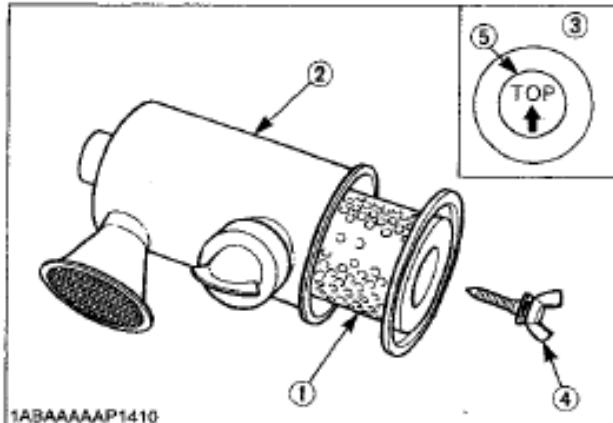

1ABAAAAAP1410

- (1) Element
- (2) Air cleaner body
- (3) Dust cup
- (4) Wing bolt
- (5) "TOP" mark

#### IMPORTANT :

- If the dust cup is mounted incorrectly, dust or dirt does not collect in the cup, and direct attachments of the dust to the element will cause its lifetime to shorten to a great extent.

## FAN BELT

### ■ Adjusting Fan Belt Tension



#### CAUTION

To avoid personal injury:

- Be sure to stop the engine and remove the key before checking the belt tension.
- Be sure to reinstall the detached safety shield after maintenance or checking.

Proper fan belt tension	A deflection of between 7 to 9 mm (0.28 to 0.35 in.) when the belt is pressed in the middle of the span.
-------------------------	--

1. Stop the engine and remove the key.
2. Apply moderate thumb pressure to belt between the pulleys.
3. If tension is incorrect, loosen the alternator mounting bolts and, using a lever placed between the alternator and the engine block, pull the alternator out until the deflection of the belt falls within acceptable limits.
4. Replace fan belt if it is damaged.

#### IMPORTANT :

- If belt is loosen or damaged and the fan is damaged, it could result in overheats or insufficient charging. Correct or replace belt.

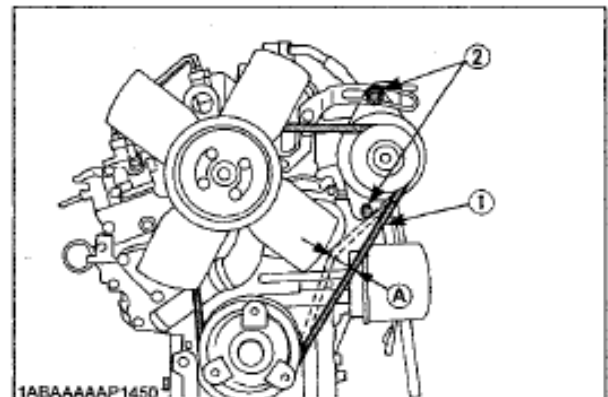

1ABAAAAAP1450

- (1) Fan belt
- (2) Bolt and nut
- (A) 7 to 9 mm (0.28 to 0.35 in.)  
(under load of 10 kgf (22.1 lbs))

### 6.2.21 *Track inspection and tensioning*

Check track tension at the inspection frequency indicated in the general chart.

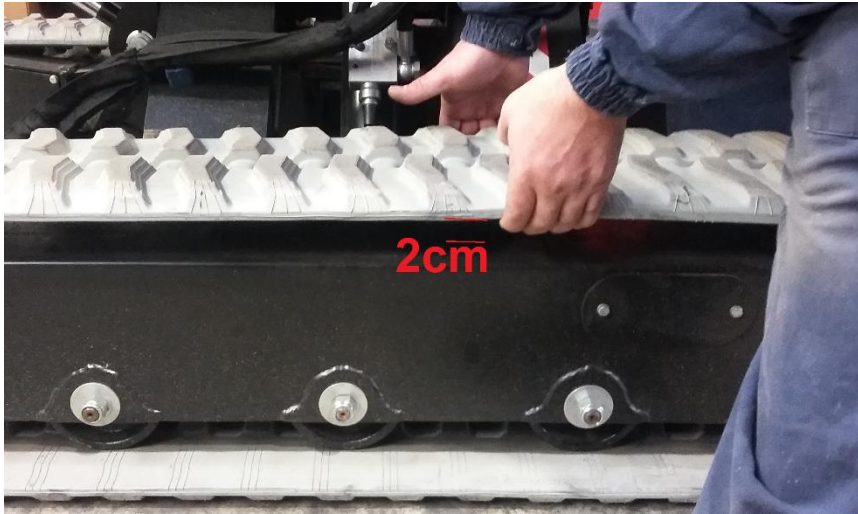

Pull the track slightly upwards in correspondence with the centre line; the deformation must be of approximately 2 cm.

If the track sags and becomes too noisy as it moves, it must be tightened as described below:

- 1) Remove the guards (1)
- 2) For proper track tension use a tensioning kit (2) - not included - and pump grease into the tensioning valve (3) until it reaches the pressure indicated below. Consult the grease chart on the next pages for the type of grease required.

Max pressure for track tensioning	Bar	200
-----------------------------------	-----	-----

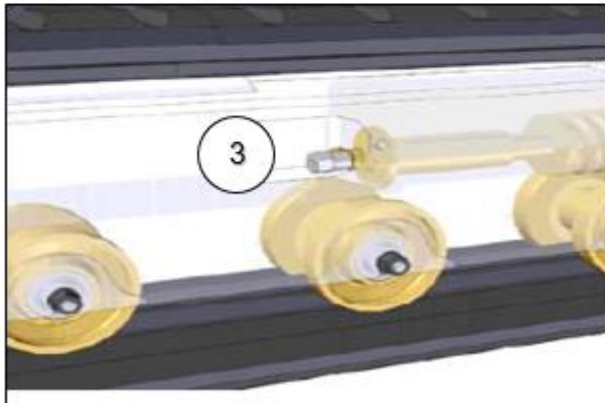
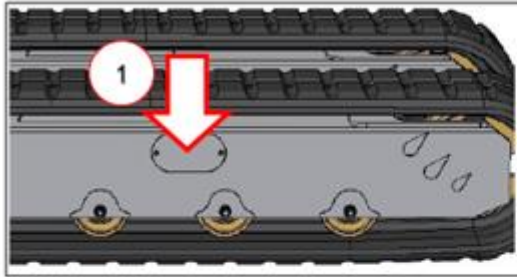

**(I) TABELLA GRASSI  
(GB) GREASE CHART**

(Il grasso normalmente utilizzato dal costruttore è PAKELO)  
(The grease generally used by the Manufacturer is PAKELO)

Grasso Grease	°C -10 ÷ 40
PAKELO	Bearing EP Grease NLGI 2
BP	Grease LTX2
CASTROL	LM2 – Speerol APT 2
SHELL	Alvania GR.R.2
ESSO	Beaocrn 2
VALVOLINE	Lithium 20
ELF	Traslube LI Grease 2

### 6.2.22 *Checking the tracks for wear*

Check the wear and condition of the tracks, replacing them when the tread is equal to or less than 10 mm.

The tracks must be changed even before they reach this limit if they are cuts or tears are noted.



Tracks must only be replaced by specialized, properly trained personnel.  
Follow the “track replacement” procedure illustrated on the following pages.

### 6.2.23 Replacing the tracks



**WARNING:** it is forbidden to open the reducer for any operation not provided for by scheduled maintenance. The manufacturer shall not be held responsible for any operations not included in scheduled maintenance that have caused damage to property and/or harmed people.

**WARNING:** USE PERSONAL PROTECTIVE DEVICES

#### Replacing the track

The track must be replaced when 10 mm of tread is left or even earlier if there are any cuts. Proceed as follows:

- 1- Do not lift the machine from the ground excessively (15-20 cm are enough).



**WARNING:** make sure that the machine is stable.

- 2- Thoroughly clean all the parts of the undercarriage
- 3- Remove the side closure of the longeron (1)

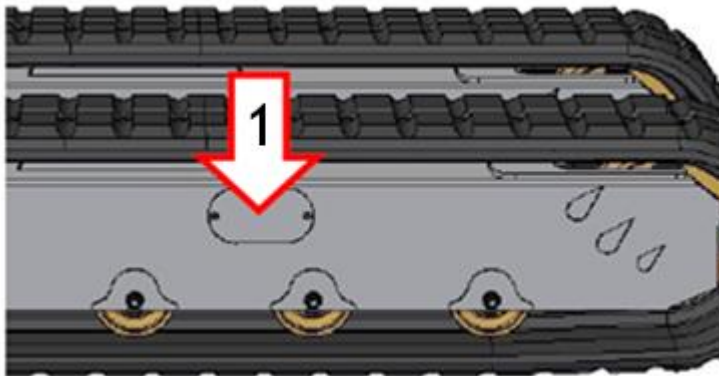

- 4- Loosen the tensioning valve (2)
- 5- Remove the tensioning valve only when it is no longer under pressure



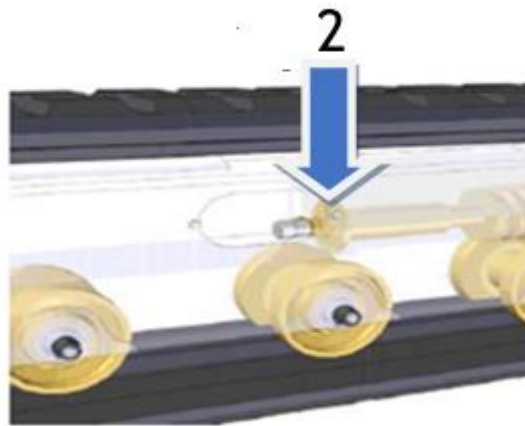

6- Using the nut supplied (point A)

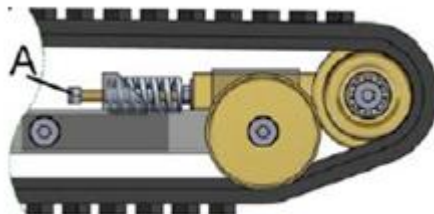

7- Move the front wheel back by pressing on the track with your foot

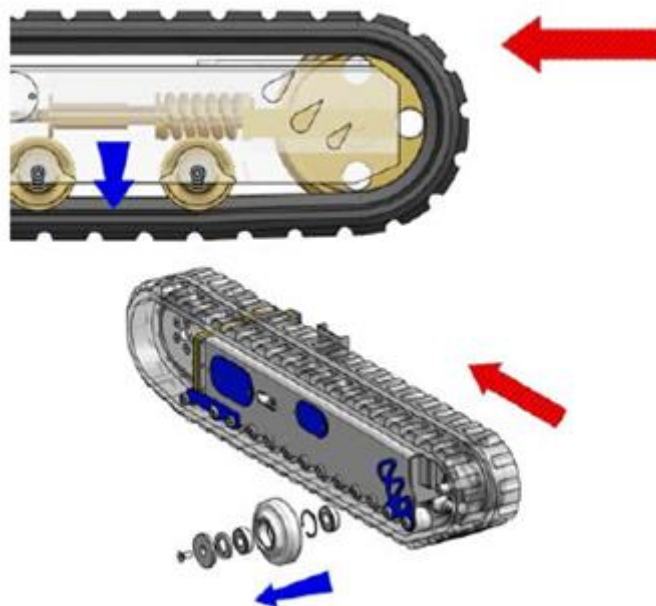



**WARNING: BE CAREFUL WHEN THE TRACK FALLS TO THE GROUND**

- 8- Lift the track at the lower centre line
- 9- Pull the track out , prying between the track itself and the idler wheel
- 10-To install the new track, proceed as indicated in the previous points, but in reverse order
- 11-The track is correctly tensioned by using the tensioning kit, pumping grease until the pressure indicated on the technical data sheet has been reached.



**WARNING: before performing the tensioning of the track, check the technical data sheet for the correct pressure expressed in bar.**

### 6.2.24 *Track reduction gear oil level inspection*

Check the level of the oil in the track reduction gears at the frequencies given in the general chart. Comply with the procedure described below.

#### **HOW TO CHECK AND TOP UP THE REDUCTION GEAR OIL**

Before proceeding, check the drawings below to find out which type of reduction gear unit is installed in your undercarriage.

Reduction gear lubrication:

The reduction gears are normally supplied without oil. The user must choose the type of lubricant depending on the indications given in the chart below.

NOTE: Each driving wheel reduction gear model has 2 oil plugs positioned at various angles, just two examples of which are illustrated here.

Reduction gear position

Turn the reduction gear until the level plug is in pos. "A", approx. 15° below the centre line of the reduction gear, as shown in the figure alongside.

Filling and level

- Pour oil into the reduction gear through the hole in pos. B until it spills from the level hole in pos. "A", then fit the plugs back in place.
- Allow the reduction gear to turn a few times so as to eliminate any air pockets, then check the various levels again.

Filling and level

This reduction gear can be installed either horizontally or vertically.

HORIZONTAL INSTALLATION (Figure 6)

- Pour oil into the reduction gear through the hole in pos "1" until it spills from the level holes in pos. "2" or "4", then fit the plugs back in place.

VERTICAL INSTALLATION (Figure 7)

- Pour oil into the reduction gear through the hole in pos. "1" or "4" until it spills from the level hole in pos. "3", then fit the plugs back in place.
- Pour oil into the reduction gear through the hole in pos "A" until it spills from the level hole in pos. "C", then fit the plugs back in place

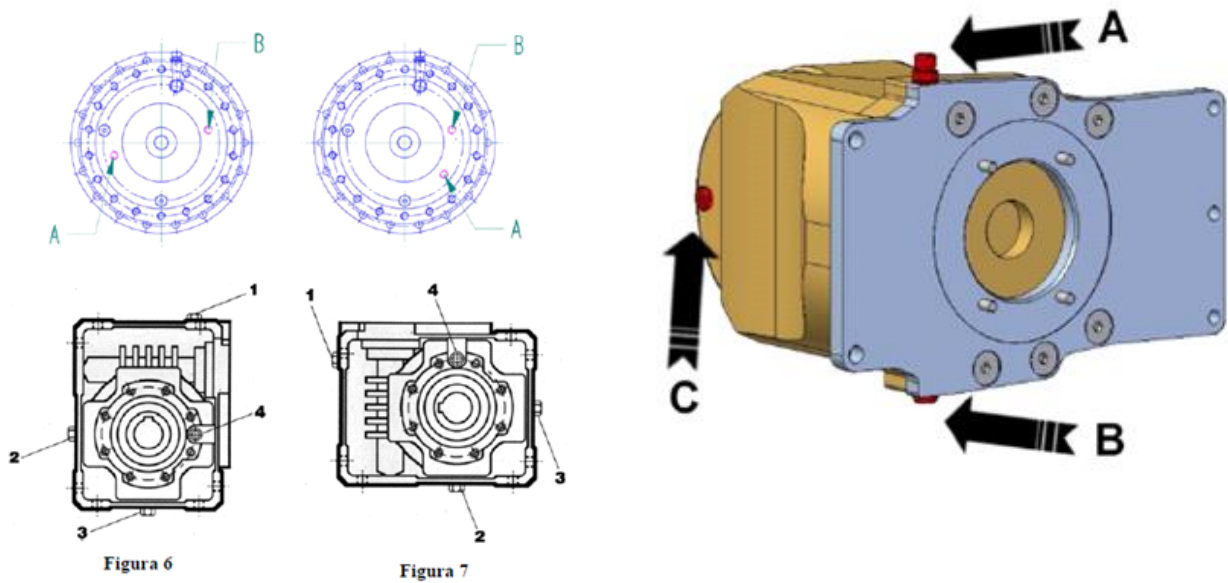

**(I) TABELLA OLII PER INGRANAGGI (PER RIDUTTORE)**  
**(GB) OIL TABLE FOR THE GEARS (FOR THE GEAR UNIT)**

(L'olio normalmente utilizzato dal costruttore è PAKELO)  
 (The oil generally used by the Manufacturer is PAKELO)

Lubrificante Lubrificant	-20C +5C IV 95 min	-5C +30C IV 95 min	+30C +50C IV 95 min	+30C +65C IV 95 min
<b>PAKELO</b>	Eurotube EP C ISO100	Eurotube EP C ISO150	Eurotube EP C ISO320	Eurotube EP C ISO460
<b>ESSO</b>	Spartan EP 100	Spartan EP 150	Spartan EP 320	Compressor Oil LG 150
<b>AGIP</b>	Blasia 100	Blasia 150	Blasia 320	Blasia SX 220
<b>ARAL</b>	Degol BG 100	Degol BG 150	Degol BG 320	Degol BG 220
<b>BP MACH</b>	GR HP 100	GR HP 150	GR HP 320	GR HP 220
<b>CASTROL</b>	Alpha SP 100	Alpha SP 150	Alpha SP 320	Alpha SN 6
<b>ELF</b>	Reductelf SP 100	Reductelf SP 150	Reductelf SP 320	Oritis 125 MS Syntherma P30
<b>CHEVRON</b>	Non leaded gear Compound 100	Non leaded gear Compound 150	Non leaded gear Compound 320	
<b>GULF</b>		EP lubrificant HD 150	EP lubrificant HD 320	
<b>I.P.</b>	Mellana 100	Mellana 150	Mellana 320	Mellana Oil 100
<b>MOBIL</b>		Mobilgear 629	Mobilgear 632	Glycoyle 22/30 SHC 630
<b>SHELL</b>	Omala Oil 100	Omala Oil 150	Omala Oil 320	Omala Oil SA
<b>TOTAL</b>	Carter EP 100N	Carter EP 150N	Carter EP 320N	
<b>KLUBER</b>	Lamora 100	Lamora 150	Lamora 320	
<b>ISO 3448</b>	VG100	VG150	VG320	VG150-200

## 7 Demolition

### 7.1 Machine life

The machine has been designed to work for 10 years in normal operating environments considering proper use and correct maintenance.

### 7.2 Decommissioning and demolition

Once the machine has reached the end of its technical and operational life, it must be subjected to a detailed and complete inspection/review by the manufacturer or specialised and qualified technicians. If the test does not have a positive outcome, the equipment must be deactivated and demolished. The machine must be reduced to conditions in which it can no longer be used for the purposes for which it was designed and built. In addition, the raw materials used to make it must be recovered for recycling purposes where possible.



Note: ALMAC S.r.l. declines all liability for damage to persons, animals or things deriving from reuse of parts of the equipment for functions or assembly situations differing from the original ones.



Danger: Machine decommissioning and demolition must be carried out only by properly trained and equipped personnel.

The machine must be demolished following the adoption of safety measures that must take account of the logistic, environmental and wear conditions of the machine itself.

Comply with the following general rules:

- wear approved protective clothing and accessories (hard-hat, safety footwear, gloves, goggles and face mask if necessary) in accordance with the accident-prevention laws in force.
- Disconnect the machine from all power sources.
- Check and, if necessary, relieve the pressure from pressurized systems.
- Ensure that the machine is unable to operate and that it cannot be used, by breaking some of its vital components and take it to a place where you are certain that it cannot be accessed by anyone.
- Use appropriate lifting devices
- Disassemble the machine into small, easily transportable units.

- Separate non-polluting materials from polluting ones when disposing of the machine (insulating materials, plastic, rubber, etc.)
- Never burn the machine or parts of it because the combustion products of plastic materials and paints could develop harmful, polluting gases.

### ***7.3 Battery disposal***

Battery recycling is mandatory (European Directive 2006/66/EC) and recommended.

- Cells and batteries, even if fully discharged, may still contain a considerable amount of energy. It is therefore necessary to always protect the terminals to prevent short circuits.
- Dispose of the batteries in compliance with local laws and regulations (contact your nearest dealer).
- Keep the material to be disposed of as indicated in the specific Section of the Safety Data Sheet attached.
- DO NOT throw into sewers, on the ground or in water courses.

## 8 ATTACHMENTS

### 8.1 Declaration of conformity

# ALMACRAWLER

## Declaration of Conformity

*Original declaration*

ALMAC S.r.l.

Viale Ruggeri 6/a

c.a.p. 42016, Guastalla (RE) - Italia

Tel 0375-833527

http: [www.almac-italia.com](http://www.almac-italia.com)

e-mail: [info@almac-italia.com](mailto:info@almac-italia.com)

P.IVA e Cod.Fisc. 02559800350

Declares, under our own responsibility that the Mobile Elevating Working Platform (M.E.W.P.):

MODEL: **BIBI 800 L TRI**

SERIAL NUMBER: **1403**

MANUFACTURING YEAR: **2017**

as described in the documentation attached to these data is in compliance with:

- Directive 2006/42/EC on machinery
- UNI EN 280:2015 Mobile elevating work platforms. Design calculations. Stability criteria. Construction. Safety requirements and tests
- UNI EN ISO 12100:2010 Safety of machinery. Risk assessment. Principles
- Directive 2014/30/EU on the approximation of the laws of the Member States relating to electromagnetic compatibility
- Directive 2000/14/EC (Annex V) on the noise emission in the environment by equipment for use outdoors
  - Measured acoustic power level (LWA): 100 dB
  - Guaranteed acoustic power level (LWA): 104 dB (the same as machine covered by EC certification (annex IV))
- ANSI A92.6-2006, CSA B354.2-01

and that, in compliance with attachment IV of the Directive, each and every part of the machine has undergone the above EC-type examination performed by:

**VERICERT srl - Certificazioni e Verifiche – Notified Body No. 1878**  
with head office in Via Luigi Masotti, 5 – 48124 Fornace Zarattini - Ravenna - Italy  
which has issued the EC-TYPE EXAMINATION CERTIFICATE:  
**1878M170756CT0416-INT.01 del 25.02.2017**

The Legal person charged with the constitution of the Technical Dossier is:

Name: **PIETRO**  
Surname: **AGOSTA DEL FORTE**  
Position: **Legal representative of ALMAC s.r.l.**

Guastalla (RE), li 11/02/2017

(Place and Date)

PIETRO AGOSTA DEL FORTE  
(Legal representative)

(Stamp and Signature)

## **8.2 Report register**

### Report register

The Report register is issued to the platform user with reference to:

- technical standard UNI EN280:2015
- Legislative Decree D.Lgs 17/2010 – Implementation of Machinery Directive 2006/42/EC

The purpose of this Register is to record events concerning the life of the machine; in detail:

- Mandatory routine inspections (INAIL, ASL, authorized bodies)
- Maintenance and obligatory inspections to check the integrity and structure of the machine and protection and safety systems
- Transfers of ownership, to be notified to the competent INAIL (former ISPESL) department
- Supplementary maintenance or replacement of important parts of the machine





Type of inspection		Description	
<b>Checking and tightening screws, bolts, plug ring nuts</b>			
	Date	Observations	Signature
1st year			
2nd year			
3rd year			
4th year			
5th year			
6th year			
7th year			
8th year			
9th year			
10th year			

**NOTE:** frequency of the operation as indicated in the table in Chapter 6. Daily registration is not necessary, but should be made at least once a year when other operations are performed.

Type of inspection		Description	
<b>Visual and structural inspection</b>		Check the integrity of the anchors, supports, carpentry, welding and pins	
	Date	Observations	Signature
1st year			
2nd year			
3rd year			
4th year			
5th year			
6th year			
7th year			
8th year			
9th year			
10th year			

**NOTE:** frequency of the operation as indicated in the table in Chapter 6. Daily registration is not necessary, but should be made at least once a year when other operations are performed.

Type of inspection		Description	
<b>Damage to tubes and cables</b>			
	Date	Observations	Signature
1st year			
2nd year			
3rd year			
4th year			
5th year			
6th year			
7th year			
8th year			
9th year			
10th year			

**NOTE:** frequency of the operation as indicated in the table in Chapter 6. Monthly registration is not necessary, but should be made at least once a year when other operations are performed.

Type of inspection		Description	
<b>Grease the runners and wheels</b>			
	Date	Observations	Signature
1st year			
2nd year			
3rd year			
4th year			
5th year			
6th year			
7th year			
8th year			
9th year			
10th year			

**NOTE:** frequency of the operation as indicated in the table in Chapter 6. Monthly registration is not necessary, but should be made at least once a year when other operations are performed.

Type of inspection		Description	
Hydraulic tank oil level inspection			
	Date	Observations	Signature
1st year			
2nd year			
3rd year			
4th year			
5th year			
6th year			
7th year			
8th year			
9th year			
10th year			

**NOTE:** frequency of the operation as indicated in the table in Chapter 6. Daily registration is not necessary, but should be made at least once a year when other operations are performed.

Type of inspection		Description	
Hydraulic reservoir oil change			
	Date	Observations	Signature
1st year			
2nd year			
3rd year			
4th year			
5th year			
6th year			
7th year			
8th year			
9th year			
10th year			

**NOTE:** frequency of the operation as indicated in the table in Chapter 6.

Type of inspection		Description	
Check the operation of the maximum pressure valve			
	Date	Observations	Signature
1st year			
2nd year			
3rd year			
4th year			
5th year			
6th year			
7th year			
8th year			
9th year			
10th year			

**NOTE:** frequency of the operation as indicated in the table in Chapter 6.

Type of inspection		Description	
Hydraulic filter replacement			
	Date	Observations	Signature
1st year			
2nd year			
3rd year			
4th year			
5th year			
6th year			
7th year			
8th year			
9th year			
10th year			

**NOTE:** frequency of the operation as indicated in the table in Chapter 6.

Type of inspection		Description	
<b>Check the operation of the angle sensors</b>			
	Date	Observations	Signature
1st year			
2nd year			
3rd year			
4th year			
5th year			
6th year			
7th year			
8th year			
9th year			
10th year			

**NOTE:** frequency of the operation as indicated in the table in Chapter 6.

Type of inspection		Description	
<b>Check the operation of the Proactive levelling angle sensor</b>			
	Date	Observations	Signature
1st year			
2nd year			
3rd year			
4th year			
5th year			
6th year			
7th year			
8th year			
9th year			
10th year			

**NOTE:** frequency of the operation as indicated in the table in Chapter 6.

Type of inspection		Description	
<b>Check the operation of the differential switch of the 230V outlet</b>			
	Date	Observations	Signature
1st year			
2nd year			
3rd year			
4th year			
5th year			
6th year			
7th year			
8th year			
9th year			
10th year			

**NOTE:** frequency of the operation as indicated in the table in Chapter 6.

Type of inspection		Description	
<b>Check the operation of the electrical insulation monitoring device (sentinel) if present</b>			
	Date	Observations	Signature
1st year			
2nd year			
3rd year			
4th year			
5th year			
6th year			
7th year			
8th year			
9th year			
10th year			

**NOTE:** frequency of the operation as indicated in the table in Chapter 6.

Type of inspection		Description	
<b>Manual emergency device operation test</b>			
	Date	Observations	Signature
1st year			
2nd year			
3rd year			
4th year			
5th year			
6th year			
7th year			
8th year			
9th year			
10th year			

**NOTE:** frequency of the operation as indicated in the table in Chapter 6.

Type of inspection		Description	
<b>Engine oil inspection</b>			
	Date	Observations	Signature
1st year			
2nd year			
3rd year			
4th year			
5th year			
6th year			
7th year			
8th year			
9th year			
10th year			

**NOTE:** frequency of the operation as indicated in the table in Chapter 6. Daily registration is not necessary, but should be made at least once a year when other operations are performed.



Type of inspection		Description	
<b>Engine oil change</b>			
	Date	Observations	Signature
1st year			
2nd year			
3rd year			
4th year			
5th year			
6th year			
7th year			
8th year			
9th year			
10th year			

**NOTE:** frequency of the operation as indicated in the table in Chapter 6.

Type of inspection		Description	
<b>Track inspection and tensioning</b>			
	Date	Observations	Signature
1st year			
2nd year			
3rd year			
4th year			
5th year			
6th year			
7th year			
8th year			
9th year			
10th year			

**NOTE:** frequency of the operation as indicated in the table in Chapter 6. Daily registration is not necessary, but should be made at least once a year when other operations are performed.

Type of inspection		Description	
<b>Track inspection and replacement</b>			
	Date	Observations	Signature
1st year			
2nd year			
3rd year			
4th year			
5th year			
6th year			
7th year			
8th year			
9th year			
10th year			

**NOTE:** frequency of the operation as indicated in the table in Chapter 6.

Type of inspection		Description	
<b>Track reduction gear oil level inspection</b>			
	Date	Observations	Signature
1st year			
2nd year			
3rd year			
4th year			
5th year			
6th year			
7th year			
8th year			
9th year			
10th year			

**NOTE:** frequency of the operation as indicated in the table in Chapter 6. Daily registration is not necessary, but should be made at least once a year when other operations are performed.

Type of inspection		Description	
Parking brake		Make sure that parking brake functions correctly when machine stops	
	Date	Observations	Signature
1st year			
2nd year			
3rd year			
4th year			
5th year			
6th year			
7th year			
8th year			
9th year			
10th year			

**NOTE:** frequency of the operation as indicated in the table in Chapter 6. Registration every six months is not necessary, but should be made at least once a year when other operations are performed.

Type of inspection		Description	
Check the Proactive levelling redundancy valves		Make sure that parking brake functions correctly when machine stops	
	Date	Observations	Signature
1st year			
2nd year			
3rd year			
4th year			
5th year			
6th year			
7th year			
8th year			
9th year			
10th year			

**NOTE:** frequency of the operation as indicated in the table in Chapter 6.

Type of inspection		Description	
Check the levelling cylinder balancing valves		Make sure that parking brake functions correctly when machine stops	
	Date	Observations	Signature
1st year			
2nd year			
3rd year			
4th year			
5th year			
6th year			
7th year			
8th year			
9th year			
10th year			

**NOTE:** frequency of the operation as indicated in the table in Chapter 6.

Serious faults		
Date	Description of fault	Solution
Spare parts used		Description
Code	qty	

Serious faults		
Date	Description of fault	Solution
Spare parts used		Description
Code	qty	

Serious faults		
Date	Description of fault	Solution
Spare parts used		Description
Code	qty	

### 8.3 Property transfers

<i>Copy to be kept</i>	
on:	
ownership of the MEWP:	
serial no.	
year of manufacture	
was transferred to:	
It is hereby certified that, as of the date above, the technical, dimensional and functional characteristics of the aforementioned platform conformed to the original characteristics and that variations, if any, have been recorded in the register.	
Seller's business name:	
Seller	
Purchaser	

<i>Copy to send to ALMAC SRL</i>	
on:	
ownership of the MEWP:	
serial no.	
year of manufacture	
was transferred to:	
It is hereby certified that, as of the date above, the technical, dimensional and functional characteristics of the aforementioned platform conformed to the original characteristics and that variations, if any, have been recorded in the register.	
Seller's business name:	
Seller	
Purchaser	

#### ***8.4 Hydraulic diagram***

See attachment

#### ***8.5 Wiring diagram***

See attachment

## 9 INDEX

<b>1</b>	<b>GENERAL INFORMATION</b>	<b>2</b>
1.1	DOCUMENTS SUPPLIED WITH EACH MACHINE	2
1.2	DETAILS OF MANUAL	2
	<i>RECIPIENTS OF THIS MANUAL</i>	2
1.3	OWNERSHIP OF THE INFORMATION	3
1.4	MANUFACTURER'S IDENTIFICATION DATA	3
1.5	MEWP IDENTIFICATION DATA	4
1.6	PERFORMANCE	5
1.7	CE DECLARATION OF CONFORMITY	11
1.8	WARRANTY	11
1.8.1	<i>Request for interventions during warranty period and formalities</i>	12
1.9	ASSISTANCE	12
1.9.1	<i>Request for assistance and repairs</i>	12
1.10	USE OF THE MANUAL	13
1.11	INTENDED USE AND IMPROPER USES	14
1.11.1	<i>Intended use</i>	14
1.11.2	<i>Improper uses</i>	15
1.11.3	<i>Cases that relieve the manufacturer from liability</i>	16
<b>2</b>	<b>SAFETY INFORMATION</b>	<b>17</b>
2.1	NOTIFICATION OF COMMISSIONING AND ROUTINE INSPECTIONS	17
2.2	FITNESS OF THE PERSONNEL	18
2.3	WARNINGS	19
2.3.1	<i>Plates indicating instructions, obligations, dangers, prohibitions and warnings</i>	19
2.3.2	<i>Meanings of the sign pictograms</i>	23
2.4	PROVISIONS AND PROHIBITIONS	24
2.5	TRANSPORT AND LOADING	25
2.6	CHECKS ON THE MACHINE BEFORE EACH USE	28
2.7	GENERAL SAFETY INDICATIONS ON THE USE OF THE PLATFORM	29
2.8	SAFETY INDICATIONS ON THE USE OF THE TRAVEL FUNCTION	30
2.9	MANDATORY SAFETY INDICATIONS TO FOLLOW BEFORE LIFTING THE WORK PLATFORM ABOVE THE TRANSPORT HEIGHT	33
2.10	SAFETY CHECKS ON THE OPERATION OF THE PLATFORM, TO BE PERFORMED BEFORE USE	34
2.11	PRECAUTIONS WHEN WORK TERMINATES OR IS INTERRUPTED	35
2.12	SAFETY REGULATIONS DURING MAINTENANCE	36
2.13	PERSONAL PROTECTIVE EQUIPMENT (PPE)	38



<b>3</b>	<b>DESCRIPTION OF THE MACHINE</b>	<b>39</b>
3.1	STRUCTURE OF THE EQUIPMENT	39
3.1.1	<i>Work platform assembly</i>	40
3.1.2	<i>Scissor assembly</i>	41
3.1.3	<i>Tank assembly</i>	42
3.2	CONTROL STATIONS	47
3.2.1	<i>Mobile control push-button panel (console)</i>	47
3.2.2	<i>Ground control using the mobile push-button panel</i>	53
3.2.3	<i>Ground controls</i>	54
3.3	STORAGE COMPARTMENT	56
3.4	PLATFORM OPERATION SAFETY DEVICES	57
3.4.1	<i>Main frame inclination control device</i>	57
3.4.2	<i>Frame and height inclination redundant control device</i>	57
3.4.3	<i>Work platform height control device</i>	59
3.4.4	<i>Load limiting device</i>	60
3.5	HYDRAULIC SYSTEM SAFETY DEVICES	61
3.5.1	<i>Hydraulic pressure limiting devices</i>	61
3.5.2	<i>Hydraulic block safety devices</i>	62
3.5.3	<i>Hydraulic failure safety devices</i>	63
3.6	BLACKOUT SAFETY DEVICES	66
3.6.1	<i>230V external power source</i>	66
3.6.2	<i>220V inverter (optional)</i>	67
3.6.3	<i>12V system</i>	68
3.7	PLATFORM OPERATION DEVICES WHICH ARE NOT PART OF THE SAFETY SYSTEM	69
3.8	FOOT PEDAL	70
<b>4</b>	<b>INSTRUCTIONS FOR USE</b>	<b>71</b>
4.1	PRELIMINARY OPERATIONS	71
4.1.1	<i>Suitability of the soil</i>	71
4.1.2	<i>Action of the wind</i>	73
4.1.3	<i>Access to the work platform</i>	74
4.1.3.1	<i>Easy-Access system to facilitate access to the work platform</i>	76
4.1.4	<i>Work platform extension</i>	77
4.1.5	<i>Checking the fuel level</i>	79
4.1.6	<i>Checking the oil level in the engine</i>	80
4.1.7	<i>Folding the railings</i>	80
4.2	MACHINE OPERATION	84
4.2.1	<i>Starting the internal combustion engine</i>	84

4.2.2	<i>Starting the current source</i>	85
4.2.3	<i>Starting the electrical engine</i>	85
4.2.4	<i>Travel controls</i>	86
4.2.4.1	Standard travel mode	89
4.2.4.2	Easy-Drive System (ED-S)	90
4.2.4.3	Direct-Control System (DC-S)	90
4.2.4.4	Turtle	91
4.2.4.5	Hare	91
4.2.4.6	Travel mode with the work platform above the transport height	92
4.2.5	<i>Levelling the platform</i>	92
4.2.5.1	Levelling in the transport configuration (with the upward movement of the work platform)	93
4.2.5.2	Levelling in the transport configuration (operating the manual controls)	94
4.2.5.3	Dynamic Levelling during travel	95
4.2.5.4	Proactive Levelling	95
4.2.6	<i>Lifting/descent of the work platform</i>	99
4.2.7	<i>Manual warning buzzer</i>	99
4.3	MESSAGES AND ALARMS ON THE HOUR COUNTER	100
4.4	STOPPING THE MACHINE	103
4.4.1	<i>Normal stop</i>	103
4.4.2	<i>Emergency stop</i>	104
<b>5</b>	<b>EMERGENCY PROCEDURES</b>	<b>105</b>
5.1	EMERGENCY MANUAL DESCENT	105
5.2	TRANSPORTING THE MACHINE IN AN EMERGENCY	106
5.3	EMERGENCY MOVEMENTS FROM HYDRAULIC BLOCK	106
5.4	USE HAND PUMP IN CASE OF EMERGENCY	107
<b>6</b>	<b>MAINTENANCE</b>	<b>109</b>
6.1	GENERAL MAINTENANCE	109
6.1.1	<i>Ordinary maintenance schedule table</i>	109
6.1.2	<i>Checks before each use</i>	111
6.2	MAINTENANCE: DETAILS	113
6.2.1	<i>Checking and tightening screws, bolts, plug ring nuts</i>	114
6.2.2	<i>Visual and structural inspection</i>	114
6.2.3	<i>Damage to tubes and cables</i>	115
6.2.4	<i>Greasing the runners</i>	115
6.2.5	<i>Greasing the nylon wheels of the platform extension</i>	116
6.2.6	<i>Checking the hydraulic tank oil level and topping up if necessary</i>	117
6.2.7	<i>Hydraulic reservoir oil change</i>	120

6.2.8	<i>Checking the operation of the maximum pressure valves</i>	121
6.2.9	<i>Battery</i>	123
6.2.9.1	General warnings	123
6.2.9.2	Maintenance	123
6.2.9.3	Recharging	123
6.2.9.3.1	Charging method No. 1 with 12V battery charger	124
6.2.9.3.2	Charging method No. 2 using the 230V plug in the ladder	125
6.2.9.3.3	Charging method No. 3 using the internal combustion engine	125
6.2.10	<i>Hydraulic filter replacement</i>	126
6.2.10.1	Suction filters replacement	126
6.2.10.2	Replacement of return filter	128
6.2.11	<i>Checking the operation of the frame angle sensor</i>	129
6.2.12	<i>Checking the operation of the scissor angle sensor</i>	130
6.2.13	<i>Checking the operation of the Proactive levelling redundant angle sensor</i>	131
6.2.14	<i>Checking the differential circuit breaker</i>	132
6.2.15	<i>Electrical insulation monitoring device operation test</i>	133
6.2.16	<i>Manual emergency device operation test</i>	134
6.2.17	<i>Checking the operation of the "Proactive levelling" safety valves</i>	135
6.2.18	<i>Checking the seal of the cylinder balancing valves</i>	136
6.2.19	<i>Procedure with remote controller for checking the seal of the cylinder balancing valves</i>	138
6.2.20	<i>Maintenance of the engine</i>	140
6.2.21	<i>Track inspection and tensioning</i>	150
6.2.22	<i>Checking the tracks for wear</i>	151
6.2.23	<i>Replacing the tracks</i>	152
6.2.24	<i>Track reduction gear oil level inspection</i>	155
<b>7</b>	<b>DEMOLITION</b>	<b>157</b>
7.1	MACHINE LIFE	157
7.2	DECOMMISSIONING AND DEMOLITION	157
7.3	BATTERY DISPOSAL	158
<b>8</b>	<b>ATTACHMENTS</b>	<b>159</b>
8.1	DECLARATION OF CONFORMITY	159
8.2	REPORT REGISTER	160
8.3	PROPERTY TRANSFERS	174
8.4	HYDRAULIC DIAGRAM	175
8.5	WIRING DIAGRAM	175
<b>9</b>	<b>INDEX</b>	<b>176</b>

