



ARX 12

LIGHT TANDEM VIBRATORY ROLLER
Tier 4i



PERFORMANCE ON THE EDGES

The Ammann ARX 12 Tandem Roller is a light, articulated ride-on roller that works flush against curbs and other obstructions and eliminates the need for special edge compaction efforts. Double-drive and double-vibration are standard and help deliver optimum compaction results. An electronic drive-lever makes for smooth starting and stopping and is among the reasons the roller is popular with operators.

COMPACTION PERFORMANCE

- Double-drive
- Double-vibration
- Optimal drum diameter
- Balanced weight front and rear
- 2 frequencies with 2 centrifugal forces

EASY MAINTENANCE

- Reliable, long-life vibration system
- Outside drain plugs for quick fluid changes
- Bearings and central articulated joint lubricated for the machine's life
- Easy access to maintenance points, water filters and nozzles
- Long service life and extended service intervals

EASY OPERATION

- Electronic drive-lever for smooth starts and stops
- Rubber-mounted platform that limits vibration
- Intuitive, ergonomic instrument panel
- Tight turning radius

EXCELLENT VISIBILITY

- Unobstructed view to drums
- Forward and backward adjustable seat

TRANSPORTABILITY

- Compact design for easy loading
- Light weight
- Foldable ROPS

REDUCED MATERIAL PICKUP

- Multiple water nozzles
- 2 scrapers per drum

APPLICATIONS

- Small and medium construction sites
- City roads
- Boardwalks
- Repair works in city centre

AMMANN

TECHNICAL SPECIFICATIONS
ARX 12 LIGHT TANDEM VIBRATORY ROLLER

DIMENSIONS

A	MACHINE LENGTH	2017 mm (79.4 in)
B	WHEELBASE	1440 mm (56.7 in)
C	MACHINE HEIGHT	2402 mm (94.6 in)
D	MACHINE HEIGHT (FOLDED ROPS)	1731 mm (68.1 in)
E	DRUM WIDTH	820 mm (32.3 in)
E	TIRE-AXLE WIDTH	-
F	MACHINE WIDTH	865 mm (34.1 in)
G	MACHINE LENGTH	2222 mm (87.5 in)
H	GROUND CLEARANCE	228 mm (9 in)
I	DRUM DIAMETER	577 mm (22.7 in)
J	DRUM SHELL THICKNESS	13 mm (0.5 in)
K	MACHINE WIDTH (TOTAL)	874 mm (34.4 in)
L	MACHINE LENGTH (FOLDED ROPS)	2327 mm (91.6 in)

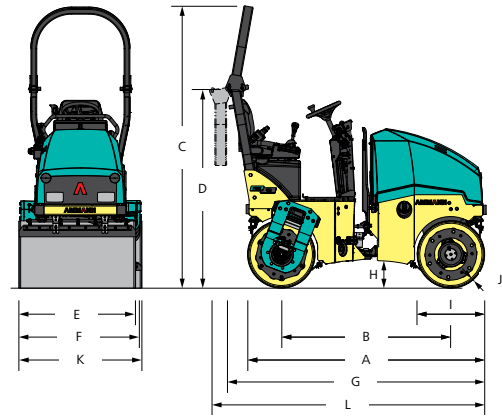

COMPACTION FORCES

AMPLITUDE	0.5 mm (0.02 in)
FREQUENCY AT 2100 / 2400 RPM	58/66 Hz (3480/3960 VPM)
CENTRIFUGAL FORCE – MAX.	23 kN

MISCELLANEOUS

BATTERY / CAPACITY	12/77 V/Ah
WATER TANK	110 l (29.1 gal)
HYDRAULIC TANK	16 l (4.2 gal)
DIESEL FUEL TANK	26 l (6.9 gal)
WHEEL LOAD	-
NUMBER OF WHEELS	-
TIRE SIZE	-

ENGINE

ENGINE TYPE	YANMAR 3TNV76
EMMISSION CLASS	EU Stage IIIA / EPA Tier 4i
POWER OUTPUT ISO 3046	15.0 kW / 20.4 HP
CYLINDER / LTR.	3 cyl / 1116 No./ccm
1. / 2. WORKING SPEED	2100 / 2400 rpm
TRAVEL SPEED KM/H	8 km/h (5 MPH)
GRADEABILITY WITH / WITHOUT VIBR.	30 % / 40 %

WEIGHT & OPERATING CHARACTERISTICS

OPERATING WEIGHT CECE	1475 kg (3251.8 lb)
OPERATING WEIGHT MAX.	1700 kg (3747.9 lb)
STATIC LINEAR LOAD (FULL-FLUSH)	9 kg/cm (19.8 lb)
TURNING RADIUS INSIDE	2165 mm (85.2 in)
STEERING / OSCILLATING ANGLE	31/5 ±°
DRUM OFFSET	50 mm (1.97 in)



STANDARD

- Front and rear vibration and drive
- Control system with emergency stop
- Pressurised pulse interval sprinkler system
- Ammann Vibration Control
- Central lifting hook
- 2 working frequencies
- Hydraulic test ports

OPTIONAL EQUIPMENT

- CE-Kit with folding ROPS and working lights
- Road lighting
- Canopy
- Asphalt thermometer
- Reverse alarm
- Battery disconnection switch
- Additional working lights (ROPS mounted)
- Arm rests
- Second drive-lever, left
- Edge-cutter incl. multi-function lever
- Bio-degradable hydraulic oil
- Drums in line
- Customer colour
- Warning beacon
- Weather canopy