

ARX 16-2

LIGHT TANDEM VIBRATORY ROLLER

EU Stage V / U.S. EPA Tier 4 final



OBSTRUCTION AVOIDER

The Ammann ARX 16-2 is a light, articulated ride-on roller that works flush against curbs and other obstructions and eliminates the need for special edge compaction efforts. The roller is powered by a Kubota engine. A new vibratory circuit setting delivers expanded frequencies that facilitate quicker compaction. The machine includes controls that enable intuitive operation; simple adjustment of soft/hard drive modes; safe and secure transport; and cost-effective serviceability.

APPLICATIONS

- Small and medium construction sites
- City roads
- Boardwalks
- Repair works in city centre

PRODUCTIVITY

Electronic drive lever

Advanced drive control enables smooth starts and stops during machine operation.

Articulation joint with oscillation

Great manoeuvrability and constant contact with the surface are key factors in achieving high quality compaction.

Sprinkling system

Multi-level filtration system with large water tank for extended intervals between fillings.

ERGONOMICS

Operator platform design

Spacious operator platform with comfortable driver's seat.

Simple & convenient operation control

Dashboard with clear display and intuitive machine control.

Exceptional operator visibility

Perfect all-around machine visibility to maximise safety on the jobsite.

SERVICEABILITY

Tool-free daily inspection

Quick and easy daily inspection.

Maintenance-free parts

Reduce time required for machine maintenance and prevent damage to components.

Service point locations

Service and regular maintenance points are quickly and easily accessible.

MAXIMUM RECOMMENDED COMPACTED LIFT THICKNESS AT OPTIMAL WORKING CONDITIONS

	Sand / gravel	Mixed soils	Silt	Clay	Stabilisation	Asphalt
ARX 16-2	200 mm (7.9 in)	150 mm (5.9 in)	-	-	100 mm (3.9 in)	80 mm (3.2 in)

TECHNICAL SPECIFICATIONS
 ARX 16-2 LIGHT TANDEM VIBRATORY ROLLER
 EU Stage V / U.S. EPA Tier 4 final

DIMENSIONS		
A	Machine length	2140 mm (84.3 in)
B	Wheelbase	1440 mm (56.7 in)
C	Machine height	2400 mm (94.5 in)
D	Machine height (folded ROPS)	1725 mm (67.9 in)
E	Drum width	900 mm (35.4 in)
F	Working width with offset	948 mm (37.3 in)
G	Machine length (folded ROPS)	2330 mm (91.7 in)
H	Ground clearance	230 mm (9.1 in)
H1	Side clearance	370 mm (14.6 in)
I	Drum diameter	580 mm (22.8 in)
J	Drum shell thickness	13 mm (0.5 in)
K	Machine width (total)	947 mm (37.3 in)

WEIGHT & OPERATING CHARACTERISTICS	
Operating weight CECE	1510 kg (3329 lb)
Operating weight max.	1655 kg (3649 lb)
Stat. lin. load of front drum	7.8 kg/cm (17 lb/in)
Stat. lin. load of rear drum	9 kg/cm (19.8 lb/in)
Turning radius inside	2210 mm (87 in)
Steering / Oscillating angle	30/6 ±°
Drum offset	48 mm (1.9 in)

ENGINE	
Engine type	Kubota D1105
Emmission class	EU Stage V, U.S. EPA Tier 4 Final
Power output ISO 3046	15.6 kW (21.2 HP)
Cylinder / ltr.	3 cyl / 1123 No./ccm
1. / 2. working speed	2400 / 2600 rpm
Travel speed	8.1 km/h (5 MPH)
Gradeability with / without vibr.	30 % / 35 %

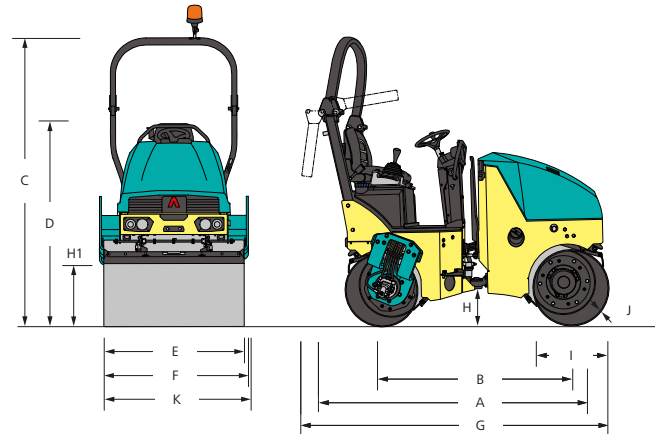

COMPACTION FORCES	
Amplitude I	0.5 mm (0.02 in)
Amplitude II	0.5 mm (0.02 in)
Frequency I	60 Hz (3600 VPM)
Frequency II	70 Hz (4200 VPM)
Centrifugal force I	20 kN (4496 lbf)
Centrifugal force II	23 kN (5171 lbf)

MISCELLANEOUS	
Battery / Capacity	12/77 V/Ah
Water tank	110 l (29.1 gal)
Hydraulic tank	28.5 l (7.5 gal)
Diesel fuel tank	24 l (6.3 gal)

STANDARD

- Front and rear vibration & drive
- Pressurised pulse interval sprinkler system
- 2 working frequencies
- Control system with emergency stop
- Ammann Vibration Control
- Central lifting point
- Hydraulic test ports
- On-board diagnostics
- Front/rear rubber bumpers
- ATC - Ammann Traction Control
- Battery disconnection switch

OPTIONAL EQUIPMENT

- CE-kit with folding ROPS and working lights
- Road lights
- Infrared thermometer
- Reverse alarm
- Additional working lights (ROPS mounted)
- Warning beacon
- Second drive-lever, left
- Arm rests
- Edge-cutter inc. Multi-function lever
- Bio-degradable hydraulic oil
- Drums in-line
- Customer color
- Weather canopy
- Servicelink