

ARX 45-2

LIGHT TANDEM VIBRATORY ROLLER
EU Stage IIIA / US EPA Tier 4 Interim



AVOIDING OBSTRUCTIONS

The Ammann ARX 45-2 Light Tandem Roller makes it easier to see – and work – near obstructions. The roller features a new articulating joint that enables quick drum adjustment from in-line to offset configurations, helpful when working close to obstructions. Operators need watch only one drum, knowing the second will be a safe distance from the obstacle. The in-line drum setting is available when it's time for productivity in open spaces.

APPLICATIONS

- Small and medium construction sites
- City roads
- Boardwalks
- City street repairs
- Road maintenance

PRODUCTIVITY

- Electronic drive lever for smooth starts and stops, especially important on asphalt jobs
- An adjustable steering joint, which enables quick changes between in-line and offset drums
- Sprinkling system 2-stage filtration system with large water tanks for extended intervals between fillings
- ACE^{force}, the Intelligent Compaction tool for optimal efficiency

ERGONOMICS

- Spacious operator platform with sliding seat
- Simple and reliable dashboard with intuitive machine control, helping inexperienced operators succeed
- Optimal all-around machine visibility for safety on the jobsite

SERVICEABILITY

- Easy and fast daily maintenance
- Accessible service and maintenance points
- Maintenance-free parts

MAXIMUM RECOMMENDED COMPACTED LIFT THICKNESS AT OPTIMAL WORKING CONDITIONS

	Sand / gravel	Mixed soils	Silt	Clay	Stabilisation	Asphalt
ARX 45-2	300 mm (11.8 in)	200 mm (7.9 in)	–	–	150 mm (5.9 in)	120 mm (4.7 in)

AMMANN

TECHNICAL SPECIFICATIONS
ARX 45-2 LIGHT TANDEM VIBRATORY ROLLER
EU Stage IIIA / US EPA Tier 4 Interim

DIMENSIONS

A	MACHINE LENGTH	2915 mm (114.8 in)
B	WHEELBASE	1950 mm (76.8 in)
C	MACHINE HEIGHT	2840 mm (111.8 in)
D	MACHINE HEIGHT (FOLDED ROPS)	2150 mm (84.6 in)
E	DRUM WIDTH	1380 mm (54.3 in)
F	WORKING WIDTH WITH OFFSET	1420 mm (55.9 in)
G	MACHINE LENGTH (FOLDED ROPS)	3000 mm (118.1 in)
H	GROUND CLEARANCE	330 mm (13 in)
I	DRUM DIAMETER	850 mm (33.5 in)
J	DRUM SHELL THICKNESS	18 mm (0.7 in)
K	MACHINE WIDTH (TOTAL)	1460 mm (57 in)

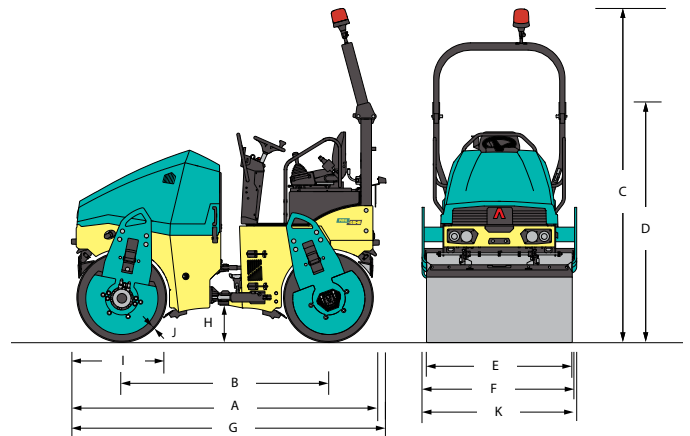

WEIGHT AND OPERATING CHARACTERISTICS

OPERATING WEIGHT CECE	4690 kg (10 340 lb)
OPERATING WEIGHT MAX.	4980 kg (10 980 lb)
STAT. LIN. LOAD OF FRONT DRUM	16.5 kg/cm (36.4 lb)
STAT. LIN. LOAD OF REAR DRUM	17.5 kg/cm (38.6 lb)
TURNING RADIUS INSIDE	2830 mm (111.4 in)
STEERING / OSCILLATING ANGLE	35/9 ±°
DRUM OFFSET	40 mm (1.6 in)

ENGINE

ENGINE TYPE	Kubota V2403-M-E3B
EMMISSION CLASS	EU Stage IIIA / US EPA Tier 4i
POWER OUTPUT ISO 3046	34.1 kW (45.7 HP)
CYLINDER / LTR.	4 cyl / 2434 cm ³
NOMINAL SPEED	2400 rpm
TRAVEL SPEED	10 km/h (6.2 MPH)
GRADEABILITY WITH / WITHOUT VIBR.	30 % / 40 %

COMPACTION FORCES

AMPLITUDE I	0.4 mm (0.016 in)
AMPLITUDE II	0.6 mm (0.024 in)
FREQUENCY I	41 Hz (2460 VPM)
FREQUENCY II	55 Hz (3300 VPM)
CENTRIFUGAL FORCE I	45 kN (10 116.4 lbf)
CENTRIFUGAL FORCE II	56.4 kN (12 679.2 lbf)
CENTRIFUGAL FORCE III	57.6 kN (12 949 lbf)

MISCELLANEOUS

BATTERY / CAPACITY	12/77 V/Ah
WATER TANK	340 l (89.8 gal)
HYDRAULIC TANK	53.5 l (14.1 gal)
DIESEL FUEL TANK	57 l (15.1 gal)

STANDARD

- Front and rear vibration and drive
- Control system with emergency stop
- Pressurised pulse interval sprinkler system
- Maintenance free vibratory system
- Lateral sliding seat
- 2 working frequencies / 2 amplitudes
- Hydraulic test ports
- Manual adjustment in-line / Offset configuration
- Maintenance-free articulation joint

OPTIONAL EQUIPMENT

- CE-Kit with folding ROPS and working lights
- Road lighting
- Asphalt thermometer
- Reverse alarm
- Battery disconnection switch
- ATC – Ammann Traction Control
- Arm rests
- Second drive-lever, left
- Edge-cutter incl. multi-function lever
- Bio-degradable hydraulic oil
- ACE^{force}
- Customer colour
- Canvas Canopy on ROPS
- Additional working lights (ROPS mounted)
- Warning beacon
- Scraper tiltable