

KATO

Mini Excavator

HD17VXE

The 1.7 ton zero tail swing mini excavator with larger digging arm for exceptional performance



YRCO.CO.NZ

YR Youngman
Richardson

Mini Excavator



HD17VXE

The 1.7 ton zero tail swing mini excavator with larger digging arm for exceptional performance

Features

- Accessible to 980mm wide, narrow spaces
- Powerful bucket digging force: 15.7kN (1600kgf)
- Excellent work ability for close-skimming
- Equipped with 3-pump system
- Comfortable joystick control with armrest
- Excellent reach & dump height
- Longer digging arm as standard

Safety

- Slew motor with automatic parking brake
- Gate lock system as standard equipment
- 4-Post canopy (ROPS) as standard equipment

Durability

- Thick rubber tracks provides high durability & life
- Rugged, steel-pressed engine cover
- Highly durable blade with extended depth & height travel
- Bucket cylinder hose built inside the arm

Easy Maintenance

- Wide, fully opening engine cover enables ease of maintenance
- Segmented boom cylinder hose design makes replacement easier
- Corrosion-free, resin fuel tank
- Highly anti-corrosive aluminum radiator

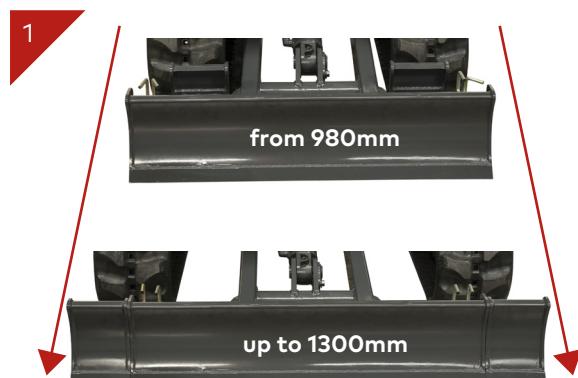

Retractable dozer blade extension

The blade width can be easily adjusted, offering you the flexibility to fit the job. Adjustment is simple and easy with the two fastening pins.

Equipped with expanding tracks as standard*

Expanding from 980mm to 1300mm with an auto lift dozer blade.



ROPS Canopy (Standard)
4 Post ROPS canopy as standard



Gate Lock System
Designed to lock all functions



Comfortable operating room

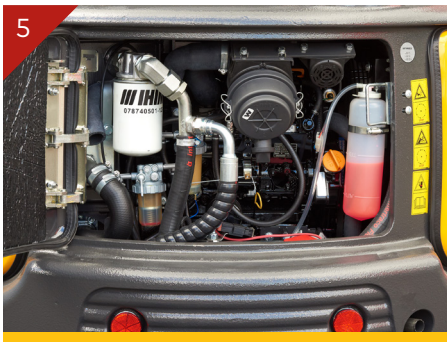

Easy maintenance with large rear access



Removeable counter weight

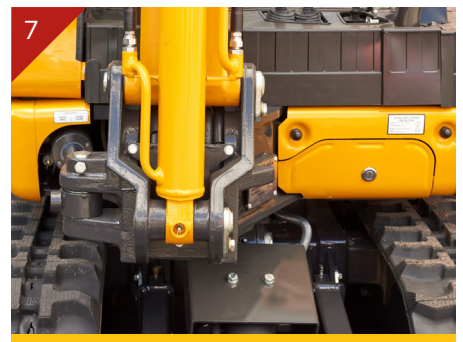

Offset boom - for increased visibility and boom rotation



Two speed selection and track extension selection on control levers

**DIGGER & TRAILER
PACKAGES
IN STOCK NOW**

PROUD TO BE 100%
NEW ZEALAND
OWNED & OPERATED



HD17VXE Mini Excavator



SPECIFICATIONS

■ Dimensions (Units mm)

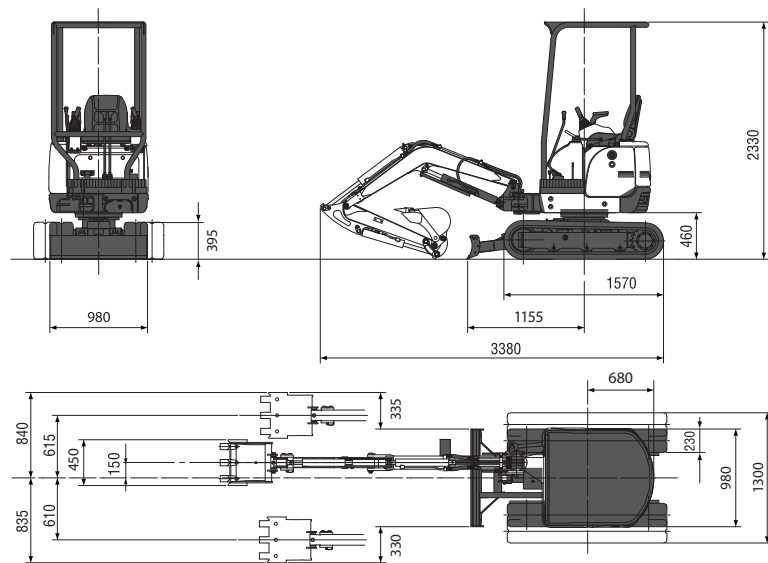

■ Working Range (Units mm)

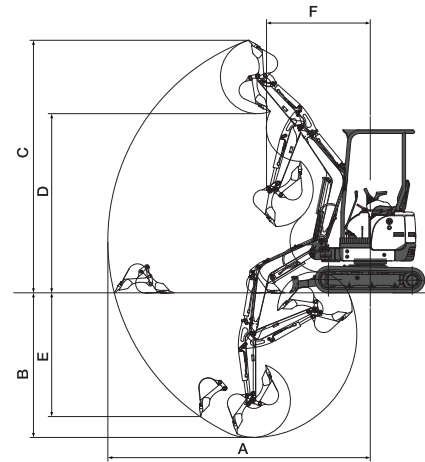

STANDARD

- 4 post ROPS canopy
- Expanding Tracks
- Flashing light
- Extra counter weigh
- Auxiliary piping

OPTIONS

- Short dipper arm
- Less counter weight

	Standard	Option (short arm)
A. Max. digging radius	3990	3760
B. Max. digging depth	2350	2100
C. Max. digging height	3810	3610
D. Max. dumping height	2760	2560
E. Max. vertical digging depth	2010	1770
F. Min. front turning radius	1580	1490
At right boom swing	1340	1280

Performance		Boom swing system	
Bucket capacity	0.037m ³	Type	Boom offset with hydraulic cylinder
Bucket width (Standard)	450mm	Swing angle (L/R)	55°/80°
Operating weight: 4-Post ROPS	1690kg	Hydraulic system	
Swing speed	9.4min ⁻¹	Pressure	20.6 Pa (210kgf/cm ²);18.1 Pa(185kgf/cm ²)
Travel speed (low/high)	2.1/4.0km/h	Pump hydraulic flow	17.2L/min x2 + 12L/min
Gradeability	58%(30°)	Dozer blade	
Ground pressure	25.6kPa (0.26kgf/cm ²)	Size (WxH)	980/1300mm x 235mm
Max bucket digging force	15.7kN (1600kgf)	Lift above ground / Drop below ground	230mm/340mm
Engine		Max auxiliary flow	
Model	YANMAR 3TNV70	Auxiliary line	29.2L/min
Rated output	10.5kW/2300min ⁻¹ (14.2Hp/2300 rpm)		
Fuel tank capacity	20L		

Product Range:



HD12VXE



HD19VXT



HD25V5

PARTS AND SERVICE

We are proud of the back-up service we offer to customers. The importance of stocking genuine spare parts for all the equipment we supply is a high company priority.

Auckland, Head Office
6-10 Parkway Drive,
Mairangi Bay,
Auckland
(+64) 09 443 2436
sales@yrco.co.nz

Auckland, Mt Wellington
20L Sylvia Park Road,
Mt Wellington,
Auckland
(+64) 09 553 5470
salesmtwell@yrco.co.nz

Wellington
8 Broken Hill Road,
Porirua,
Wellington
(+64) 04 212 2456
saleswell@yrco.co.nz

Christchurch
20 Nga Mahi Road,
Sockburn,
Christchurch
(+64) 03 341 6923
saleschch@yrco.co.nz

