

Mini Excavator HD25V5

A 2.5 ton zero tail swing mini excavator
with exceptional performance



ROPS Cabin version available.

Mini Excavator



HD25V5

A 2.5 ton zero tail swing mini excavator with exceptional performance

Features

- Newly designed operator's space
- Zero tail swing
- Easy maintenance
- Low fuel consumption
- Powerful digging & quick response

Safety

- Gate lock system
- Neutral engine start
- ROPS / FOPS cabin or canopy (canopy standard)
- Auto parking brake in swing & traction motors

Durability

- Easily adjustable pins for longer life
- Castle nuts for boom & arm joints
- Single structured swing pin

Easy Maintenance

- Large side covers for easy access & maintenance
- Wide, fully opening engine cover enables ease of maintenance
- Filters are conveniently located - Includes: Large fuel filter, water separator & tank breather



4 ROPS canopy standard

Comfortable Operating Room



Centralised switches - includes key start, throttle dial, auto idle & eco mode



Easily visible monitor - includes travel speed, auto idle, eco mode, hour meter & engine management



Full suspension seat - c/w retracting seat belt



Control Lever with proportional switch for auxiliary hydraulic



Traction foot pedals (fold away)



Mini Excavator



Easy maintenance



Large rear access for easy engine maintenance



Large side cover for easy service access



Water separator with indicator

Safety



Gate Lock System



ROPS Cabin (Option)



Single-structured Swing Pin

Track options

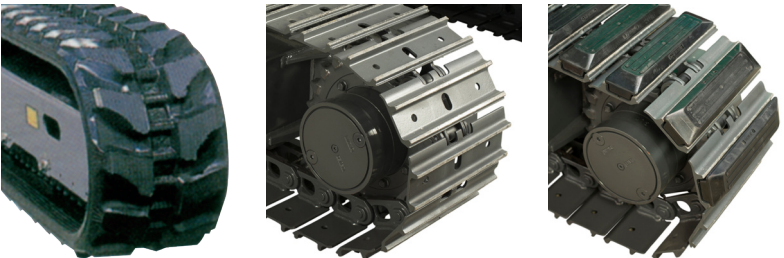

Rubber Tracks / Steel Track / Rubber Pad Options

Easy skimming work



Close distance between Bucket Tooth and Dozer Blade

Easy fuel refilling



Fuel refill located in a convenient position

Lower Fuel Consumption

Max. 24% fuel saving*

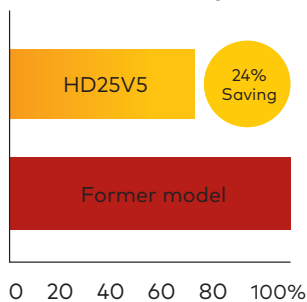

High Digging Power & Quick Response

Digging force increased by 10%
Highly responsive 3-pump system

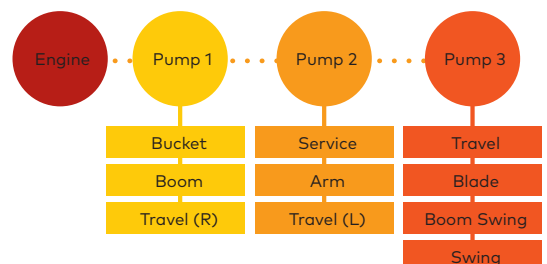

HD25V5 Mini Excavator



SPECIFICATIONS

■ Dimensions (Units mm)

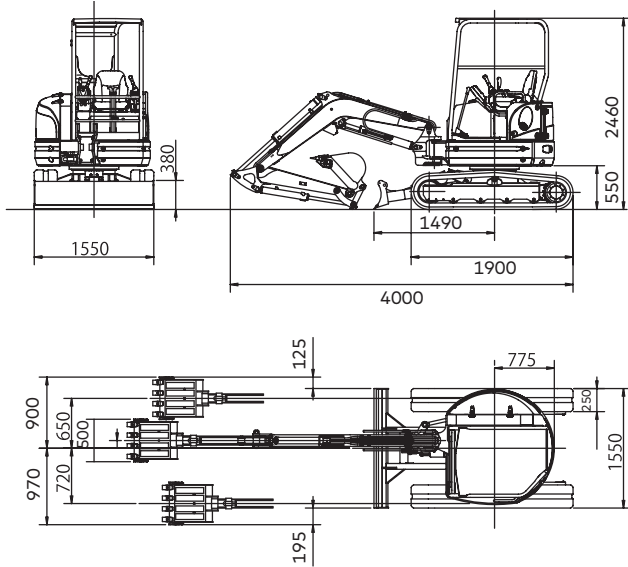

■ Working Range (Units mm)

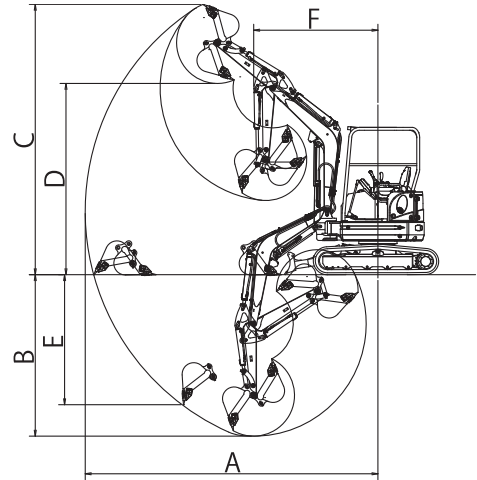

STANDARD

- ROPS canopy
- Auxiliary piping
- Flashing light
- Rubber tracks

OPTIONS

- ROPS cabin
- Steel tracks
- Rubber pads
- Short arm

	Standard	Option (Short arm)
A. Max. digging radius	4840	4560
B. Max. digging depth	2740	2440
C. Max. digging height	4410	4220
D. Max. dumping height	3090	2900
E. Max. vertical digging depth	2120	1840
F. Min. front turning radius	2090	2030
At right boom swing	1790	1740

Performance		Boom swing system	
Bucket capacity	0.08m3	Type	Boom offset with hydraulic cylinder
Bucket width (Standard)	500mm	Swing angle (L/R)	80°/50°
Operating weight: 4-Post(Cabin)	2575 (2725) kg	Hydraulic system	
Transportation weight: 4-Post(Cabin)	2500 (2650) kg	Pressure	21.6MPa 220kgf/cm ² / 18.1MPa 185kgf/cm ²
Swing speed	9.0min ⁻¹	Pump hydraulic flow	28.8 L/minx2+ 19.2L/min
Travel speed (low/high)	2.5 / 4.4km/h	Dozer blade	
Gradeability	58% (30°)	Size	1550/380mm
Ground pressure	31kPa (0.32kgf/cm ²)	Lift above ground / Drop below ground	355mm / 410mm
Max bucket digging force	21kN (2140kgf)	Max auxiliary flow	
Engine		1st Auxiliary line	48L/min
Model	KUBOTA D1305-E4B	2nd Auxiliary line	19L/min (Option)
Rated output (EU version)	17.6kW / 2400min ⁻¹		
Fuel tank capacity	42L		

Product Range:

* Youngman Richardson & Co Ltd reserve the right to change specifications at any time.



PARTS AND SERVICE

We are proud of the back-up service we offer to customers. The importance of stocking genuine spare parts for all the equipment we supply is a high company priority.



Auckland, Head Office
6-10 Parkway Drive,
Mairangi Bay,
Auckland
(+64) 09 443 2436
sales@yrco.co.nz

Auckland, Mt Wellington
20L Sylvia Park Road,
Mt Wellington,
Auckland
(+64) 09 553 5470
salesmtwell@yrco.co.nz

Waikato
3/31 Chafer Place,
Te Rapa,
Hamilton
(+64) 07 595 0245
saleswaikato@yrco.co.nz

Wellington
8 Broken Hill Road,
Porirua,
Wellington
(+64) 04 212 2456
saleswell@yrco.co.nz

Christchurch
20 Nga Mahi Road,
Sockburn,
Christchurch
(+64) 03 341 6923
saleschch@yrco.co.nz

