

Mini Excavator

HD12VXE

The 1.2 ton zero tail swing mini excavator
with exceptional performance



Mini Excavator



HD12VXE

The 1.2 ton zero tail swing mini excavator with industry leading specification

Features

- Accessible to 900mm wide narrow spaces
- Powerful bucket digging force: 11.9kN (1210kgf)
- Excellent work ability for close-skimming
- Equipped with 3-pump system
- Comfortable joystick control with armrest
- Smallest front radius in its class: 1440mm
- Excellent reach & dump height

Safety

- Slew motor with automatic parking brake
- Gate lock system as standard equipment
- Folding 2 post TOPS as standard equipment, can be folded down for easy storage

Durability

- Thick rubber tracks provides high durability & life
- Rugged, steel-pressed engine cover
- Highly durable blade with extended depth & height travel
- Bucket cylinder hose built inside the arm

Easy Maintenance

- Wide, fully opening engine cover enables ease of maintenance
- Segmented boom cylinder hose design makes replacement easier
- Corrosion-free, resin fuel-tank
- Highly anti-corrosive aluminum radiator

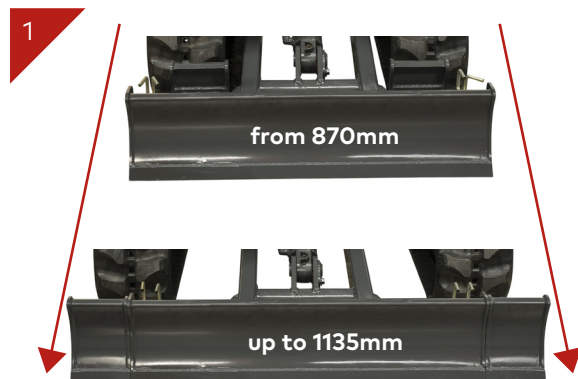

Retractable dozer blade extension

The blade width can be easily adjusted, offering you the flexibility to fit the job. Adjustment is simple and easy with the two fastening pins.

Equipped with expanding tracks as standard*

Expanding from 870mm to 1135mm with an auto lift dozer blade.



TOPS (Folding)
2 Post TOPS as standard



TOPS in folded position



Gate Lock System
Designed to lock all functions



Comfortable operating room
with comfortable leg room



Easy maintenance with large rear access



Fully incorporated counter weight



Offset boom - for increased visibility and boom rotation



Two speed selection and track extension selection on joystick

**DIGGER & TRAILER PACKAGES
IN STOCK NOW**



HD12VXE Mini Excavator



SPECIFICATIONS

■ Dimensions (Units mm)

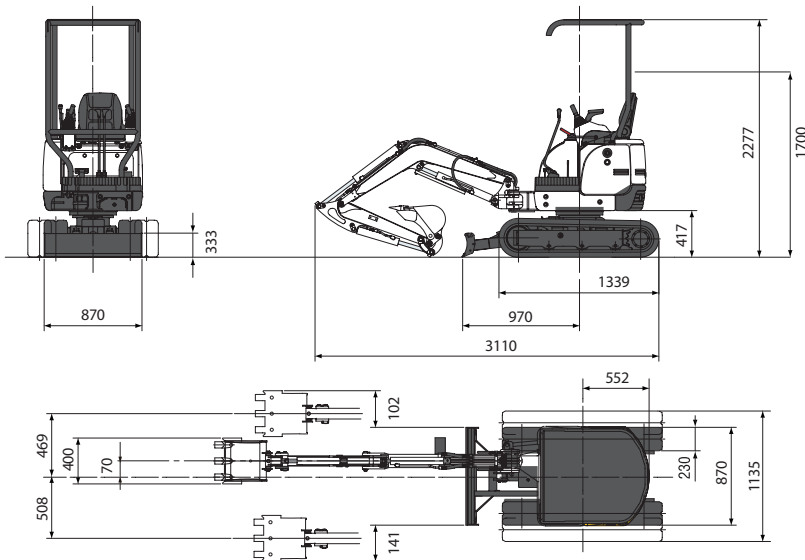

■ Working Range (Units mm)

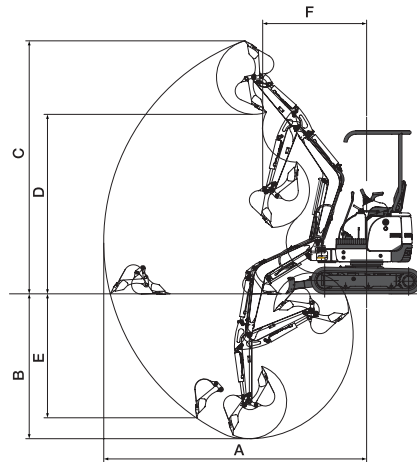

STANDARD

- 2 post TOPS canopy
- Expanding Tracks
- Flashing light
- Auxiliary piping

| 4-Post canopy | Standard |
|--------------------------------|----------|
| A. Max. digging radius | 3456 |
| B. Max. digging depth | 2010 |
| C. Max. digging height | 3052 |
| D. Max. dumping height | 2173 |
| E. Max. vertical digging depth | 1487 |
| F. Min. front turning radius | 1530 |
| At right boom swing | 1290 |

| Performance | | Boom swing system | |
|-------------------------------|---|---------------------------------------|--|
| Bucket capacity | 0.036m ³ | Type | Boom offset with hydraulic cylinder |
| Bucket width (Standard) | 400mm | Swing angle (L/R) | 50°/80° |
| Operating weight: 4-Post ROPS | 1180kg | Hydraulic system | |
| Swing speed | 8.5min ⁻¹ | Pressure | 20.6 Pa (210kgf/cm ²), 18.1 Pa (185kgf/cm ²) |
| Travel speed (low/high) | 2.3/4.0km/h | Pump hydraulic flow | 13.2L/min x2 |
| Gradeability | 58%(30°) | Dozer blade | |
| Ground pressure | 26.2kPa (0.27kgf/cm ²) | Size | 870mm/1130mm x 230mm |
| Max bucket digging force | 11.86kN (1210kgf) | Lift above ground / Drop below ground | 230mm/210mm |
| Engine | | Max auxiliary flow | |
| Model | YANMAR TNM68 | Auxiliary line | 26L/min |
| Rated output | 9.5kW/2200min ⁻¹ (12.9Hp/2200 rpm) | | |
| Fuel tank capacity | 12.5L | | |

Product Range:



HD17VXE



HD19VXT



HD25V5

PARTS AND SERVICE

We are proud of the back-up service we offer to customers. The importance of stocking genuine spare parts for all the equipment we supply is a high company priority.

Auckland, Head Office
6-10 Parkway Drive,
Mairangi Bay,
Auckland
(+64) 09 443 2436
sales@yrco.co.nz

Auckland, Mt Wellington
20L Sylvia Park Road,
Mt Wellington,
Auckland
(+64) 09 553 5470
salesmtwell@yrco.co.nz

Wellington
8 Broken Hill Road,
Porirua,
Wellington
(+64) 04 212 2456
saleswell@yrco.co.nz

Christchurch
20 Nga Mahi Road,
Sockburn,
Christchurch
(+64) 03 341 6923
saleschch@yrco.co.nz



YR Youngman
Richardson