

Genie® Z[®]-40/23N RJ

Specifications

Models	Z-40/23N RJ	
Measurements	US	Metric
Working height max. ⁽¹⁾	46 ft 5 in	14.32 m
Platform height max.	40 ft 5 in	12.32 m
Horizontal reach max.	22 ft 8 in	6.91 m
Up and over clearance max.	21 ft 3 in	6.48 m
A Platform length	2 ft 6 in	0.76 m
B Platform width	3 ft 10 in	1.17 m
C Height - stowed	6 ft 6 in	1.98 m
D Length - stowed	21 ft 5 in	6.53 m
E Width	4 ft 11 in	1.50 m
F Wheelbase	6 ft 5 in	1.96 m
G Ground clearance - center	9.5 in	0.24 m

Productivity

Lift capacity max. - unrestricted	500 lb	227 kg
Platform rotation	180°	
Jib length	4 ft	1.22 m
Vertical jib rotation	128°	
Horizontal jib rotation	180°	
Turntable rotation	355°	
Turntable tailswing	5 in	0.13 m
Drive speed - stowed ⁽²⁾	4.5 mph	7.2 km/h
Drive speed - raised	0.68 mph	1.1 km/h
Gradeability - stowed ⁽²⁾	30%	
Tilt sensor activation (front to back/side to side)	2.5° - 4.5° / 4.5°	
Turning radius - inside/outside	2 ft 11 in / 10 ft 6 in	0.87 m / 3.20 m
Tires (solid, non-marking)	22×7×17.75 in	0.56×0.18×0.45 m

Power

Power	48V DC (8×6V 350Ah)
Drive system	48V 3-Phase AC
Auxiliary power unit	24V DC
Hydraulic tank capacity	8 gal / 30.3 L

Weight⁽³⁾ and Floor Loading⁽⁴⁾

Weight	15,300 lb	6,940 kg
Tire contact pressure	200 psi	1379 kPa
Occupied floor pressure (tires)	372 psf	17.8 kPa

Sound and Vibration Levels

Sound Pressure level (ground workstation)	< 70 dBA
Sound Pressure level (platform workstation)	< 70 dBA
Vibrations	8 ft 2 in/s ² / 2.5 m/s ²

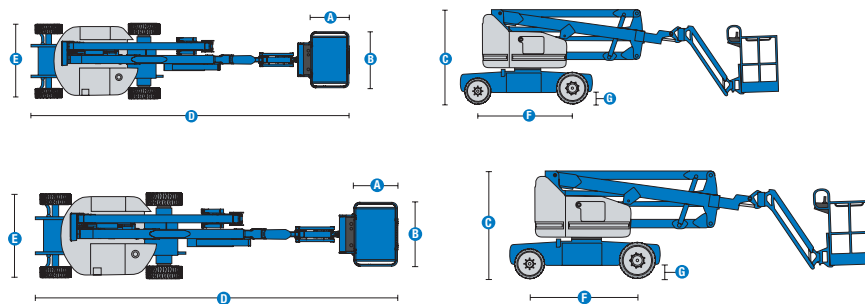

Range of motion Z-40/23 N RJ

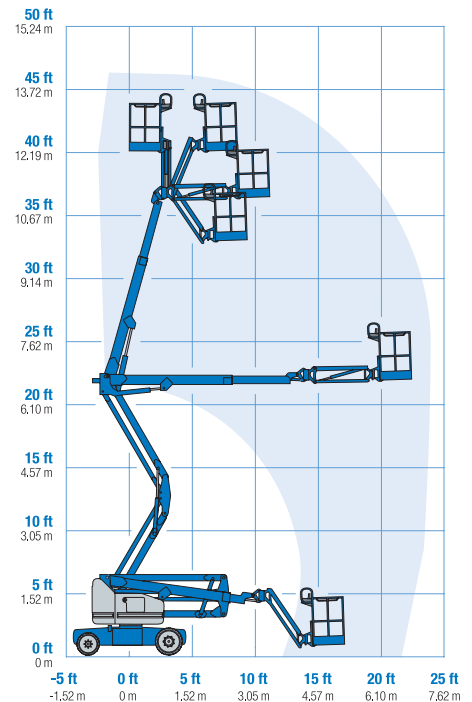

Jib range of motion Z-40/23N RJ

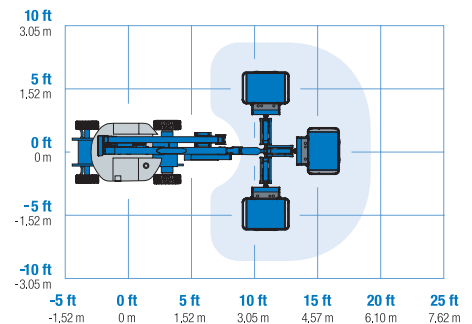

(1) The metric equivalent of working height adds 2 m to platform height. The imperial equivalent adds 6 ft to platform height.
 (2) Gradeability applies to driving on slopes and may vary depending on options and machine configurations. See operator's manual for details regarding slope ratings.
 (3) Weight refers to standard configuration and may vary depending on options and/or country standards.
 (4) Floor loading information is approximate and may vary depending on options and machine configurations. It should be used only with adequate safety factors.

Genie® Z[®]-40/23N RJ

SKU: Standard Model

• **Z40NRJ01UE0007:** Z-40/23N RJ, DC Power, 2WD

* Build to Order

Option availability		S	S+	BtO
Power	Standard FLA flooded lead acid battery	✓	✓	✓
	AGM Maintenance-free batteries			○
	Battery Isolation Kit		○	○
	Low voltage interrupt (LVI) with battery charge indicator (BCI)	✓	✓	✓
Platform	4ft 8in/1.42m steel platform	✓	✓	✓
	Thumb rocker steering	✓	✓	✓
	240Volt Power To Platform Kit		○	○
	3ft 10in/1.17m steel platform	✓	✓	✓
	Airline to Platform		○	○
	Control box covers (Ground and Platform)			○
	Half Mesh Aluminium 5FT Platform Kit			○
	Harness Container Double		○	○
	Harness Container Single Kit		○	○
	Harness Fall Arrest Lanyard		○	○
	LED Flashing Beacon		○	○
	Light Package: drive and work lights			○
	Platform Worklights		○	○
	White Noise Alarm Kit		○	○
	4ft/1.2m Jib	✓	✓	✓
	AC Power cord to platform	✓	✓	✓
	Drive enable system	✓	✓	✓
	Horn	✓	✓	✓
	Lift Guard Contact Alarm	✓	✓	✓
	Platform Control Box Cover Kit	✓	✓	✓
	Platform level cutout	✓	✓	✓
	Platform load sense system	✓	✓	✓
	Proportional controls	✓	✓	✓
	Self-leveling platform	✓	✓	✓
	Travel alarm package: flashing beacons, descent, travel and tilt alarms	✓	✓	✓
	Chassis	Lift Connect Telematics		○
Lift Connect with Access Manager upgrade			○	○
Solid, non-marking tyres		✓	○	○
Drive Lights			○	○
Fire Extinguisher 2.5KG 3A:40B:E			○	○
Wheel Chock Kit			○	○
Wheel Nut Indicator			○	○
2 wheel steering		✓	✓	✓
Chassis tilt drive function cut-out		✓	✓	✓
Dual parallelogram lift linkage		✓	✓	✓
Electric brake release		✓	✓	✓
Hour meter		✓	✓	✓
On-board diagnostic system		✓	✓	✓
Sealed AC electric drive motors		✓	✓	✓
Tech Pro Link connector	✓	✓	✓	
Telematics-Ready	✓	✓	✓	

- S Standard
- S+ Standard +
- BtO Build to Order
- ✓ Standard Features
- Options



Efficient Electric Drive System



Narrow Access



Rotating Jib



Genie Genuine Accessories⁽¹⁾

- Lift Tools Productivity Tools
- Lift Connect Telematics
- Tech Pro Link Handheld Device

(1) More accessories available from Genie Genuine Parts.

Product specifications are subject to change without notice or obligation. Photographs and/or drawings herein are for illustrative purposes only. Refer to the appropriate Operator's Manual for instructions on proper equipment use. Failure to follow instructions in the Operator's Manual may result in serious injury or death. The only warranty applicable to our equipment is the standard written warranty applicable to the particular product and sale and we make no other warranty, express or implied. Products and services listed may be trademarks, service marks or trade names of Terex Corporation and/or their subsidiaries in the USA and many other countries. Terex, Genie, Quality By Design, Xtra Capacity, Lift Power, Lift Guard, Lift Tools, Lift Connect and Tech Pro Link are registered trademarks of Terex Corporation or its subsidiaries.

12/22