



ABG 2820

ASPHALT PAVERS TRACKED

EU STAGE V



Talented all-rounder

- Quiet and clean: low noise, low emissions
- Single or dual conveyor configurations
- Individually operated hopper wings
- 9-tonne hopper capacity
- 110-liter fuel tank capacity

Comfort and convenience

- Fully adjustable operator station
- All-weather roof, electro-hydraulic foldable, integrated sound insulation
- New storage areas
- EPM3: intuitive controls from bigger pavers, Settings Manager
- Glazed sides (option)

The screed you need

- New VB40 screed: pave from 1.8–4.5 meters
- Variomatic VB30 screed: 1.5–4 meters
- Slim hydraulically controlled end gates (VB40)
- Fully adjustable screed console

High uptime, low costs

- Easy battery access, with external panel for jump starting
- 3 lubricating points = low daily maintenance
- Maintenance-free bearings for conveyor
- Diesel Particulate Filter with no SCR and no AdBlue
- CareTrack telematics system
- VB40 with lifetime lubricated tamper and vibration bearings

Sophisticated tracks

- 150 mm longer undercarriage for excellent balance and traction
- Auto track tensioner for smooth paving starts*
- Durable track scrapers for a smoother surface finish
- Relocated bolts for quicker track pad changes

**AN ABG EXCLUSIVE FEATURE*

ABG 2820

EU Stage V

ENGINE		ABG 2820
MANUFACTURER		Volvo (Kubota)
MODEL		D3.8H
FUEL		Diesel
OUTPUT	kW	55.4
	hp	75.3
AT ENGINE SPEED	r/min	2 200
COOLANT		Liquid
FUEL TANK CAPACITY	l	110
EXHAUST EMISSION		EU Stage V

PAVING

OUTPUT (THEORETICAL)*	t/h	330 with single conveyor 230 with double conveyor
MAT THICKNESS (MAX)	mm	250

*The actual paving output depends upon the mat thickness, the paving width and paving speed and will vary according to paving conditions prevailing on your jobsite.

SPEED

PAVING (MAX)	m/min	20
TRANSPORT (MAX)	km/h	4.5

UNDERCARRIAGE

LENGTH	mm	1 833
WIDTH (TRACK PLATES)	mm	160

CONVEYOR

HOPPER CAPACITY	t	9
NUMBER OF CONVEYORS		1 or 2
CONVEYOR SPEED (MAX)	m/min	17.9

AUGER

NUMBER OF AUGERS		2
SPEED (MAX)	1/min	72
DIAMETER	mm	300

DIMENSIONS

		ABG 2820
LENGTH WITH VB40 SCREED (WALKWAY UP)	mm	4 871
LENGTH WITH VB30 SCREED	mm	5 300
WIDTH	mm	1 740
HEIGHT	mm	3 994
HEIGHT (TRANSPORT)	mm	2 899

WEIGHT

TRACTOR UNIT	kg	8 155
--------------	----	-------

Approximative weight, without options.

Diesel tank half-full, 75 kg operator, standard hopper and weather roof included.

MAX. ALLOWABLE GRADEABILITY

TRACTOR UNIT + SCREED	%	36
-----------------------	---	----

When using extensions the max. allowable gradeability will be reduced.

SOUND LEVEL

L_{PA} Sound Pressure Level at Driver's Ear, acc. to ISO 11201	dB	85
L_{WA} Guaranteed Sound Power Level, acc. to Directive 2000/14/EC	dB	106

VIBRATION

HAND-ARM VIBRATION accord. to ISO 5349:2001	m/s ²	<2.5
WHOLE BODY VIBRATION accord. to ISO 2631:1997	m/s ²	<0.5

ELECTRICAL SYSTEM

BATTERY VOLTAGE	V	24
-----------------	---	----

OPERATING WEIGHTS* OF SCREEDS IN KG AT WORKING WIDTH

ABG 2870	3.0 m	3.5 m	4.0 m	4.5 m
VB40 ETC MIN Mechanical crown control and standard end-gates	-	1 638	1 977	2 186
VB40 ETC MAX Hydraulic crown and hydraulic end-gates	-	1 720	2 058	2 267
VB30 ETC MIN	1 856	-	2 260	-
VB30 ETC MAX	1 873	-	2 277	-

* Including auger extensions, channel plates, end-gates.

TRACKED ASPHALT PAVERS

DIMENSIONS [mm]

ABG 2820

A	OPERATING LENGTH	5 300
B ₁	OPERATING HEIGHT	3 995
B ₂	HEIGHT WEATHER ROOF	3 720
B ₃	SHIPPING HEIGHT	2 899
C	TRACTOR WIDTH	1 740
D ₁	HEIGHT RAILING	2 523
D ₂	DECK HEIGHT	1 493
D ₃	SCREED HEIGHT	877
E ₁	OUTER HOPPER WIDTH	3 240
E ₂	INNER HOPPER WIDTH	3 103
E ₃	WIDTH OSCILLATING BEAM	2 559
F ₁	EXTENSION WEATHER ROOF	580
F ₂	SEAT CONSOLE EXTENSION	542
G ₁	INNER LOADING HEIGHT	552
G ₂	OUTER LOADING HEIGHT	701
H ₁	HOPPER LENGTH TO PUSH ROLLER	1 985
H ₂	HOPPER LENGTH	1 805
J ₁	DISTANCE REAR WALL AUGER CENTRE	225
J ₂	DISTANCE AUGER SCREED	230
J ₃	SCREED DEPTH	850
K ₁	AUGER HEIGHT TO GROUND (CENTER)	350-90
K ₂	DIAMETER AUGER	300
L	GROUND CLEARANCE	145
M	DIAMETER WHEEL	-
N	DIAMETER PUSH ROLLER	110
O	CONVEYOR WIDTH	710
S ₁	BASIC SCREED WIDTH VB 30	1 500
S ₁	BASIC SCREED WIDTH VB 40	1 800
S ₂	EXTENDED SCREED WIDTH VB 30	3 000
S ₂	EXTENDED SCREED WIDTH VB 40	3 500
T ₁	FRONT WHEEL/TRACK TO PUSH ROLLER	960
T ₂	DISTANCE FRONT WHEELS	-
T ₃	TRACK LENGTH/WHEEL BASE	1 833
T ₄	TRACK/WHEEL DISTANCE TO REAR WALL	589
U ₁	WHEEL/TRACK GAUGE WHEELS/TRACKS CENTRE TO CENTRE	1 150
U ₂	TRACK PAD WIDTH/WHEEL WIDTH	260
W ₁	WIDTH OF WALKWAY	300
W ₂	HEIGHT OF WALKWAY	295

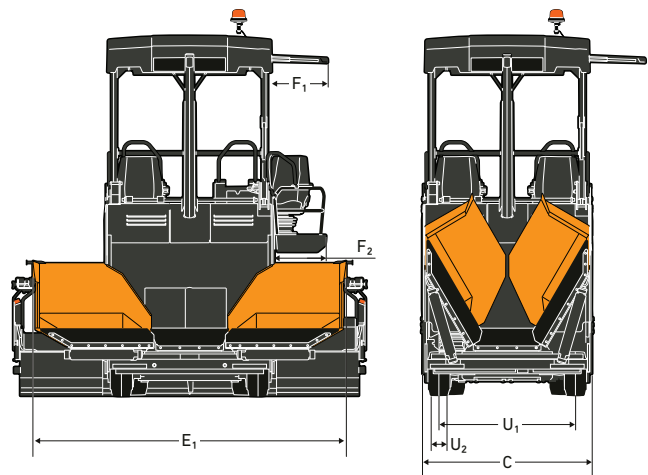
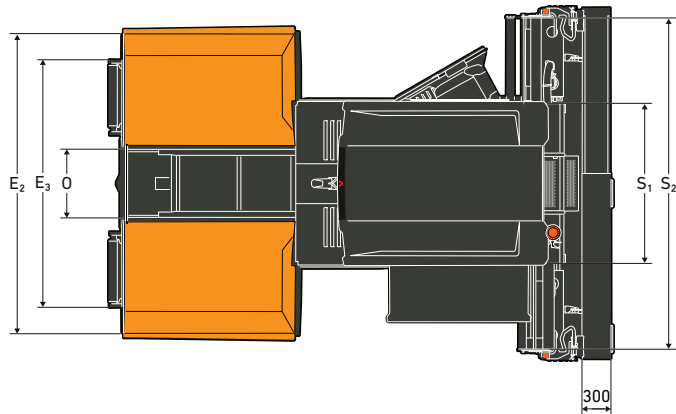
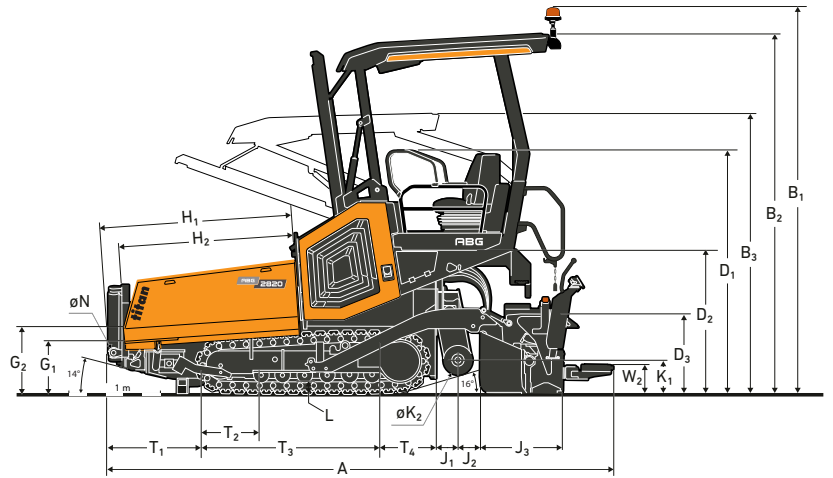

EQUIPMENT

STANDARD EQUIPMENT

Engine

- Volvo (Kubota) Diesel engine, EU Stage V

Drive

- Electronic drive control
- Load dependent efficient drive system
- Automatic track tensioner
- Lifetime lubricated crawler track rollers
- Forged and hardened crawler track links
- Smart rubber pads

Material Management

- Proportional conveyor control
- Reversible direction of auger rotation
- Single conveyor
- Mechanical auger height adjustment
- Oscillating cross beam with two mounting positions
- 110 mm Push roller

Electrics and electronics

- Electronic Paver Management (EPM 3)
- Settings Manager
- Service interval manager
- Adjustable and slideable control station

- Two adjustable and revolving screed control panels
- Battery master switch
- Electric switching cabinet
- Back-up alarm
- Tool kit
- MATRIS support

Structure

- Manual folding all-weather roof Glass-fibre Reinforced Plastic (GRP)
- Two swing out seats
- Storage compartment under weather roof
- Near field mirrors at weather roof
- ABG Key

Screed

- VB 30 ETC 1.50–3.0 m
- Mechanical crown adjustment
- Screed lock
- Split towing arms

Lights

- Work lights
- Operator's platform lighting
- Home light function

Environmental

- Sound insulation for engine compartment and operator station

OPTIONAL EQUIPMENT

Material Management

- Two Independent conveyors
- Reversible conveyor
- Individual operating hopper wings
- Mechanically operated front apron
- Hydraulically operated front apron
- Push-roller D110 plus 100 mm more space
- Proportional ultrasonic auger control

Electrics and electronics

- Lateral emergency stop
- Additional socket 230V 50Hz
- Traction isolator switch
- CareTrack GSM | Satellite
- Levelling equipment
- Case for control panels

Structure

- Deluxe seats with heating and USB charger
- Electrohydraulic powered weater roof
- Seat side windshield
- Without Weather Roof

Screed

- Screed anti-climbing lock
- Screed Assist
- Hydraulic end-gates (VB 40)
- Hydraulic heated end-gates (VB 40)
- Hydraulic crown adjustment
- Paving width reduction
- Edging shoes 3/5/7/12 cm

Lights

- Worklights LED
- Two additional rear lights LED
- Additional auger light LED
- Additional lights levelling scale LED
- Portable worklight LED with magnetic base
- Warning beacon LED

Environmental

- Extractor for bituminous fumes
- Integrated emulsion spraying system with hose reel
- High performance spray cleaning unit
- Biodegradable hydraulic oil and Bypass filter